

LIGHTING COLLECTION



HAY



Content

Overview

Aplat

Ava

Compass

Twist

Aspekt Buoy

Cupola

Drome

Ono

Apex

Turn On

Noc

Brim

Apollo

Arcs

Host

Mousqueton

Parade

Matin

Bonbon

Pao

Anagram

LBM

Factor Linear

Paper Cube

Slant

PC

Nelson Bubble

Common

Marselis

30 Degrees

Dimensions



HAY Lighting

HAY's Lighting collection is an extensive selection of carefully curated designs that offer durable and innovative lighting solutions by some of the world's most talented designers. In our endeavour to create longer lasting and more energy-efficient lights, we offer universal designs based around LED light sources, which strive to balance functionality with originality.

HAY Lighting covers a diverse range of needs and environments, offering versatile options that can be integrated into domestic, professional, and public settings.

Ceiling Lamps



Ava Cone
Pendant



Compass
Pendant



Aspekt Buoy
Glass



Brim



Pao Steel



Pao Glass



PC Pendant



Matin Pendant



Matin Flush Mount



Apollo Chandelier 745



Apollo Chandelier 1065



Nelson Bubble
Ball



Nelson Bubble
Ball Crisscross



Nelson Bubble
Saucer



Nelson Bubble
Saucer Crisscross



Nelson Bubble
Cigar



Nelson Bubble
Cigar Crisscross



Nelson Bubble
Pear



Nelson Bubble
Pear Crisscross



Nelson Bubble
Apple



Nelson Bubble
Bell



Nelson Bubble
Lantern



Nelson Bubble
Propeller



Nelson Bubble
Angled Sphere



Nelson Bubble
Roll



Factor Linear Suspension



PC Linear

Lamp Shades



Arcs



Bonbon 310



Bonbon 320



Bonbon 380



Bonbon 500



Paper Shade
for Common
Lamp Base
Peach



Paper Shade
for Common
Lamp Base
Oblong



30 Degrees



Apollo

Table Lamps



Aplat



Ava Pyramid



Aspekt Buoy
Glass



Cupola Desk



Apex Desk



Apex



Apex Desk
Clip



PC Double Arm



Matin



Anagram



Drome



Pao Glass



PC



Slant



Parade



LBM



LBM Corner



Paper Cube



Turn On



Common Base



Marselis

Portable Lamps



Host



Parade



Mousqueton



PC



Apollo



Pao

Clip Lamps



Cupola

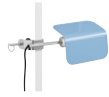

Apex



Noc

Wall Lamps



Ava Square



Apex



Ono Flush Mount
200



Ono Flush Mount
350



Arcs Switch



Arcs Sconce



Matin



Nelson Ball
Sconce



Nelson Cigar
Sconce



Nelson Pear
Sconce



Nelson Saucer
Sconce



Apollo Wall
Sconce Lamp



Noc Wall



Noc Wall Button



Cupola

Floor Lamps



Twist



Apex



Matin



Pao Steel



Pao Glass



Common

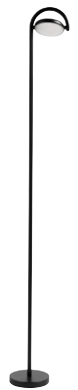

Marselis



Paper Cube

Cord Sets



Common
Pendant Cord Set



Common
Table Cord Set

Aplat Design by CPRV

Designed by Camille Paillard and Romain Voulet, the French duo behind CPRV, the Aplat Table Lamp emerged from playful experiments with paper. Its name, taken from the French word for 'flat,' reflects the transformation of a two-dimensional sheet folded into a shaped graphic form. Crafted primarily from paper, Aplat is both lightweight and sculptural, with a diffused surface that casts a warm, candle-like glow, bringing atmosphere and intimacy to its surroundings. Delivered flat-packed and assembled by the user, its minimal construction and discreet metal hook make it easy to move wherever light is needed.



Photograph by Max Verret

Founded in 2020, CPRV is a collaborative design studio run by Camille Paillard and Romain Voulet, based between London, UK, and Marseille, France. Working across furniture, lighting, products, and interiors, the studio explores how design interacts with everyday life, focusing on simplicity, materiality, and long-lasting function.



Aplat Table Lamp 660



The diffused paper surface emits an ambient glow reminiscent of candlelight.

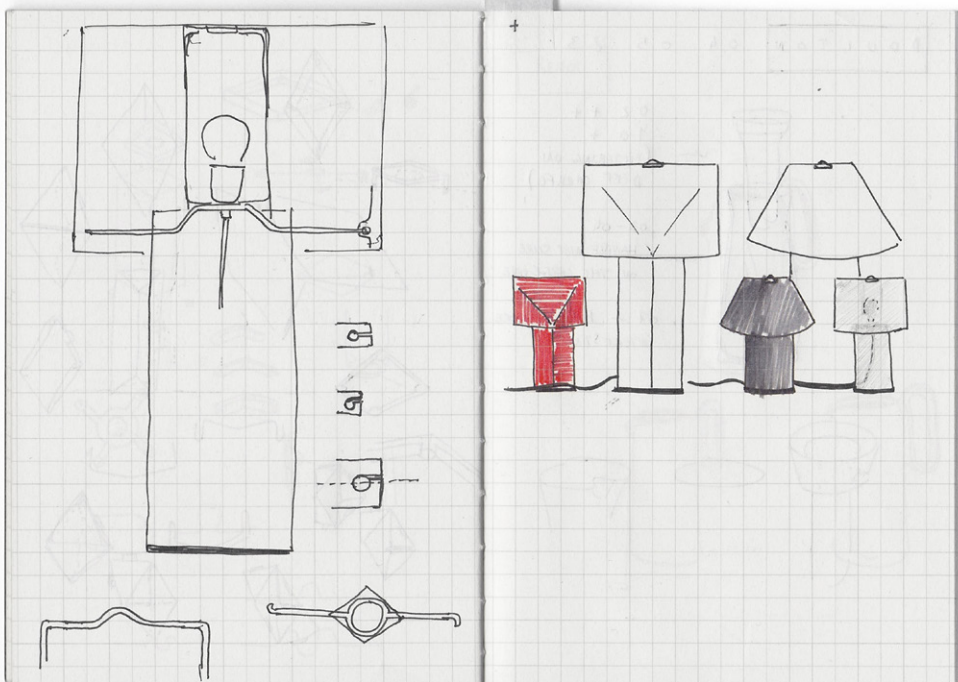

The Aplat Table Lamp emerged from playful experiments with paper.





Aplat Table Lamp Family





Aplat Table Lamp 660

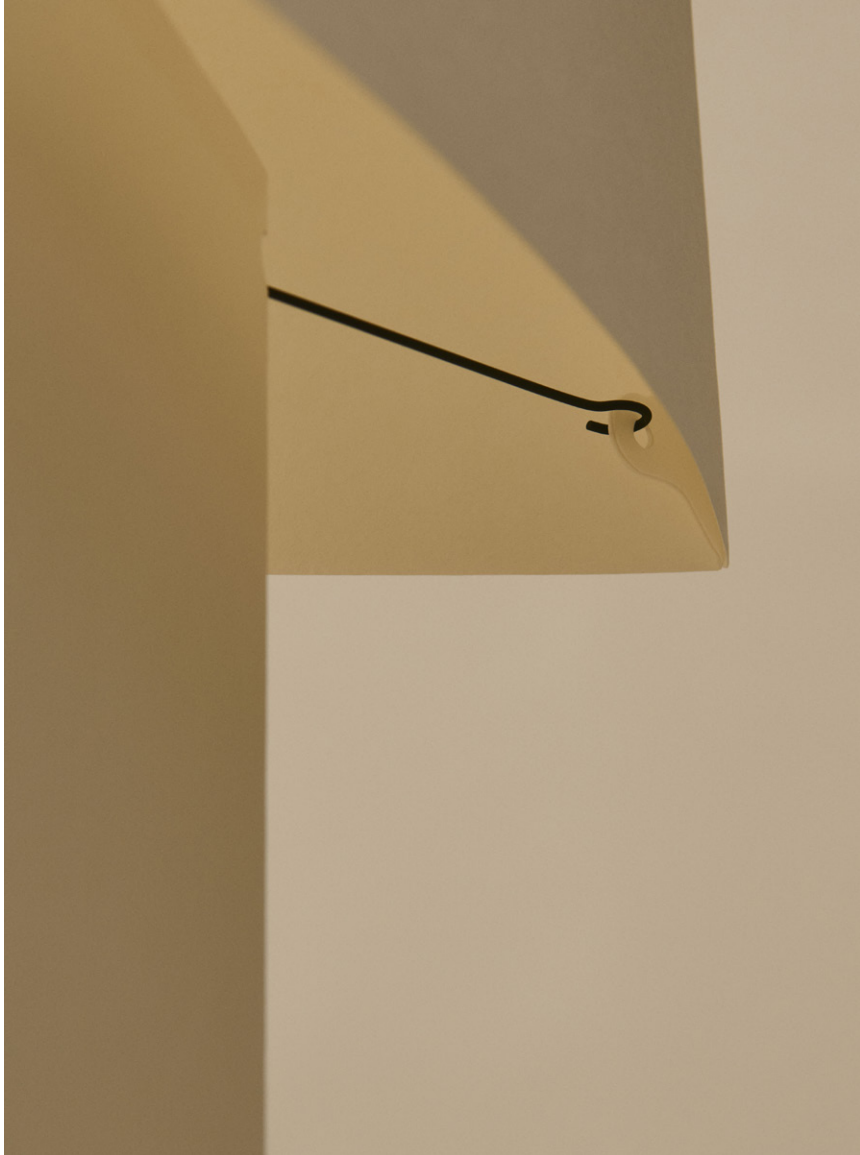

Ava

Design by Ana Kraš

Designed for HAY by Ana Kraš, the Ava Lamp collection combines an archetypal lamp shape with a bold, graphic design, creating a contemporary take on a classic lamp. Crafted from ECOPE™ derived from recycled PET plastic, the semi-translucent shade has a paper-like quality that is offset by the contrasting fabric piping. Available in pendant, table, and wall lamp variants, Ava's simple yet striking visual presence and soft, ambient glow allow it to integrate seamlessly into numerous home spaces – as a table lamp on shelves and windowsills, a pendant suspended from the ceiling, or as wall-mounted lighting. The pendant and table lamp models are accompanied by HAY's Common Cord Set.

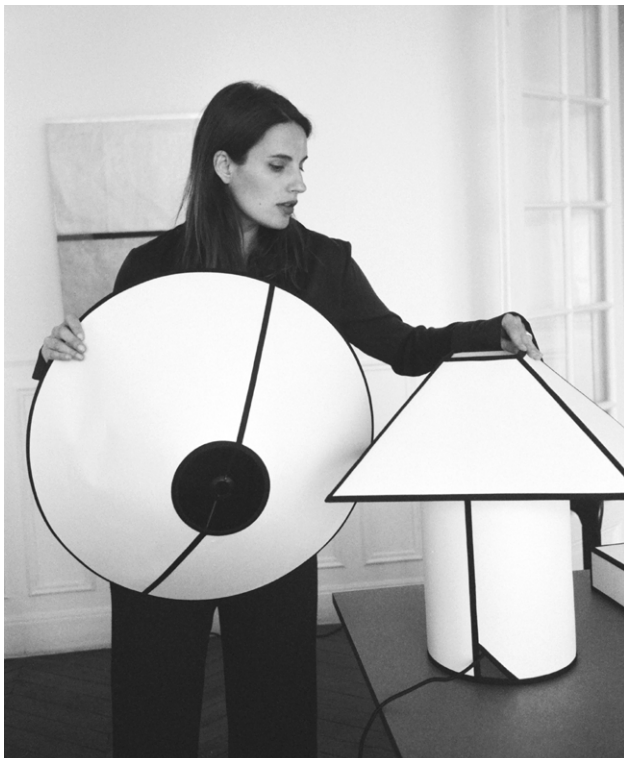

Anna Krás

Known for her distinctive work across object design, art, photography, and fashion, Serbian designer Ana Kraš studied furniture design and interior architecture in Belgrade, and currently divides her time between Paris and New York. For HAY, Ana has also designed the Bonbon Lamp Shade and the Ram Series of home textiles.



Ava Collection

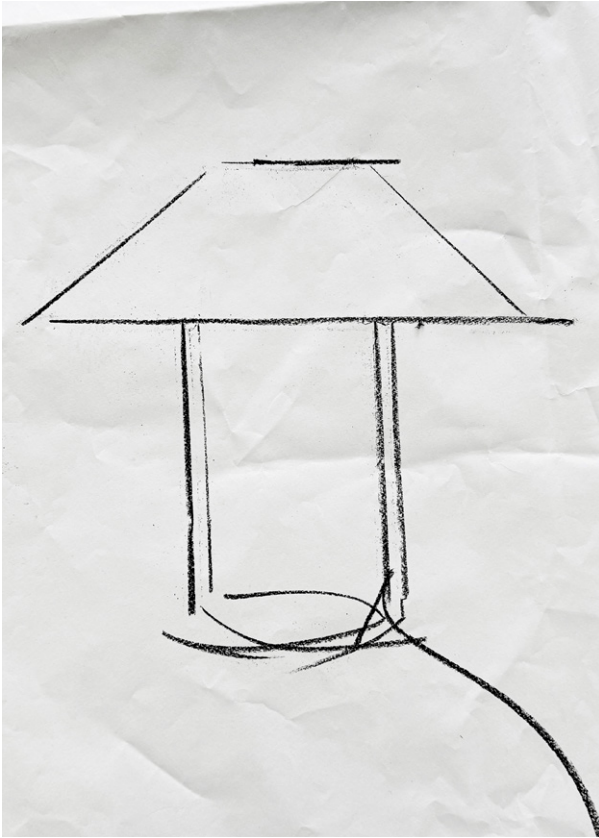

Ava Lamp is the result of an impromptu design made from wire, paper, and textile tape after Ana moved into a new apartment in Paris in 2021.





What began as a spontaneous idea has evolved into a refined collection of table, wall, and pendant lights.





Ava Pyramid Table Lamp 450



Ava Pyramid Table Lamp Family



Ava Square Wall Lamp





Ava Cone Pendant 600



Compass

Design by Julien Renault

Designed by Julien Renault for HAY, Compass is a series of lamps based on the classic pendant typology, unified by their distinctive conical silhouette. The angled shade is available in a classic model with fixed cord length, as well as a height-adjustable variant with counterbalanced weight that enables users to precisely position the direction and height to suit their preferences. Crafted in aluminium with different finishes and size options, Compass offers a versatile lighting solution that complements both domestic and office environments.



Julien Renault

French designer Julien Renault blends rational methods with artistic freedom in his approach to design. Based in Brussels, he draws inspiration from everyday life, transforming the ordinary into something beautiful. For HAY, Julien has also designed the Pastis Table and Chair series and Layout Armchair.



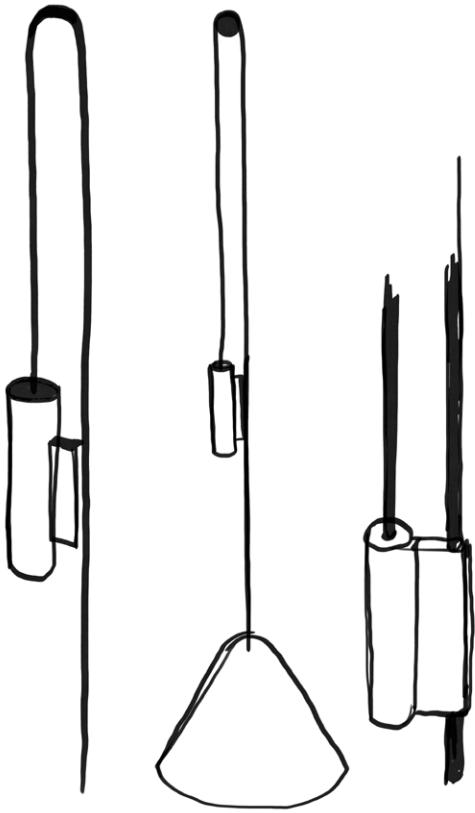

The counterbalanced height-adjustable pendant allows precise positioning, providing ambient glow or focused task light.











Compas Pendant | 260 Pompeian red



Compass Pendant | 260 & 430 Brushed aluminium



Compass Pendant | Pompeian red & Soft Black





Compass Adjustable Pendant | Brushed aluminium



Twist

Design by Romain Sillon

Designed for HAY by Romain Sillon, Twist is a height-adjustable lamp with a bold, innovative design. Its intuitive adjustment mechanism offers flexibility in both the position and lighting distribution, enabling it to serve different functions and create diverse atmospheres within a space, depending on its height. Twist's minimalist aesthetics and versatile design make it adaptable to a wide variety of spaces and uses within different interiors.



Romain Sillon

Romain Sillon combines his background in product design with a meticulous and methodical approach. From his own design practice in Paris, he explores mechanics and movement to create a subtle, unexpected poetry in his work.



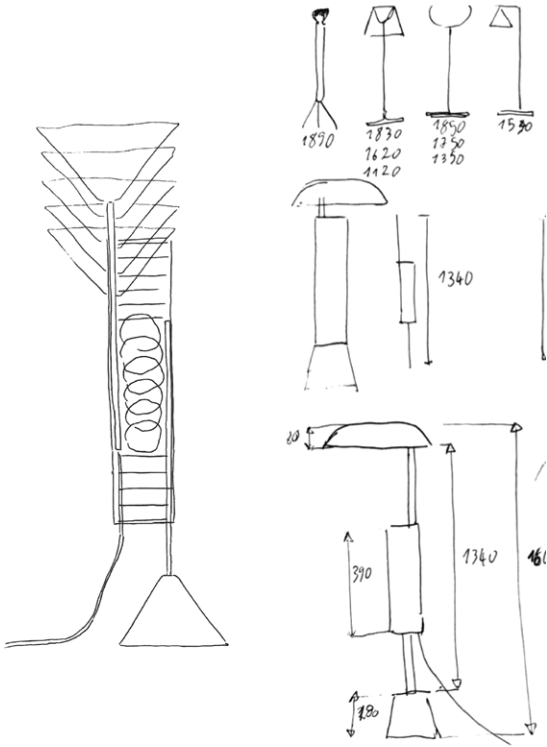

A technically refined floor lamp with soft upward light and adjustable height. Its smart extending mechanism allows the lamp to reach up to two metres.













Aspekt Buoy Design by Apekt Office

Designed for HAY by Danish design studio Aspekt Office, the Aspekt Buoy Glass Lamp Collection fuses appealing aesthetics with functional design to create an ambient light that blends effortlessly into its surroundings. Comprising an opaque glass-blown shade paired with HAY's Common Cord Set, Aspekt Buoy's naturally curved, organic silhouette offers a simple yet captivating lighting solution. Available as Pendant and Table Lamps, providing atmospheric, directional light that suits a wide variety of uses and rooms. Easy to mount and maintain without tools, both lampshade variants are available in two sizes with cord sets in different colour options.



Aspekt Office

Based in Copenhagen, Aspekt Office is a design studio, specialising in furniture, product, interior design and creative direction. Founded in 2018 by Hans Toft Hornemann and Terkel Skou Steffensen, the designer duo uses conceptual thinking and original ideas in their intuitive approach to design. For HAY, Aspekt Office have also designed the Ono Flush Mount.



Aspekt Buoy Glass Lamp Collection



Inspired by the form of nautical floating buoys, the glass material plays a central role in the appearance and design of the lamp.







Aspekt Buoy Glass Pendant 300



Aspekt Buoy Glass Pendant 200



Aspekt Buoy Glass Table Lamp 300



Cupola

Design by John Tree

Cupola is a collection of adjustable lamps that explores the possibilities of providing optimal movement using minimal mechanisms. All the lamp designs feature circular domed heads that are distinctive in their simplicity, while offering a highly technical lighting solution. Crafted in durable aluminium with a natural anodised finish, the lamps balance a raw, industrial expression with rounded forms. Available as a Clip Lamp, Desk Lamp, and Wall Lamp, all equipped with a 360° rotating head and pivoting mount to provide localised, directional light to suit specific uses and rooms.



John Tree

John Tree is a London-based designer working from his own studio, focusing on furniture, lighting, and electronics. His work explores industrial processes and has earned recognition through international publications and prestigious design awards.



Cupola Lamp Collection

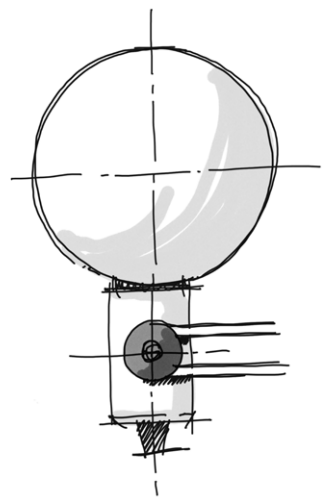
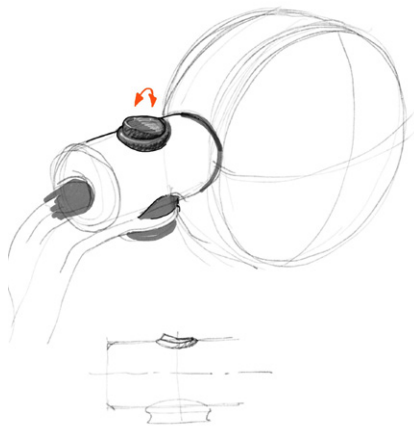
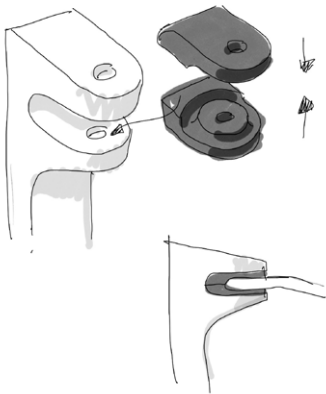



Cupola Desk Lamp



Cupola Clip Lamp



Cupola Desk Lamp



Drome

Design by Christian Juhl

Drome is a versatile table lamp defined by its distinctive oval shape. The lamp's stretched elliptical form changes the perception of the lamp, depending on which angle it is viewed from. Concealed inside the hollow form is a replaceable integrated light source, creating a unified, minimalistic silhouette that enables light to glow through it. The inline step dimmer allows the light output to be adjusted, making the lamp a versatile light source that can be used to create atmosphere in a variety of environments and settings, from a bedside table or desk to a windowsill or bookshelf.



Christian Juhl is a Danish product and furniture designer based in Copenhagen. Using an explorative approach to materials, crafts, and joinery, he aims to create contemporary and long-lasting design solutions.





Concealed inside the hollow form is a replaceable integrated LED light source that brings soft, ambient light to its surroundings.





The lamp's stretched elliptical form changes the perception of the lamp, depending on which angle it is viewed from.





Ono

Design by Aspekt Office

Designed for HAY by Aspekt Office, Ono Flush Mount is a functional and uncluttered lamp with strong, simple aesthetics. Designed with optimal versatility and minimal details in mind, the lamp's clean, symmetrical lines create a graphic expression. The centrally located light source is surrounded by the conical shade, creating a halo effect that diffuses a warm, welcoming light. Its neutral yet characterful design enables Ono Flush Mount to be used on walls and ceilings in many different rooms and environments, including bathrooms, porches, and other partially covered outdoor spaces. Available in two different sizes.







Designed with minimal details in mind, the lamp's clean, symmetrical lines create a graphic expression.





Drawings and proto samples of Ono Flush Mount.



Ono Flush Mount 350

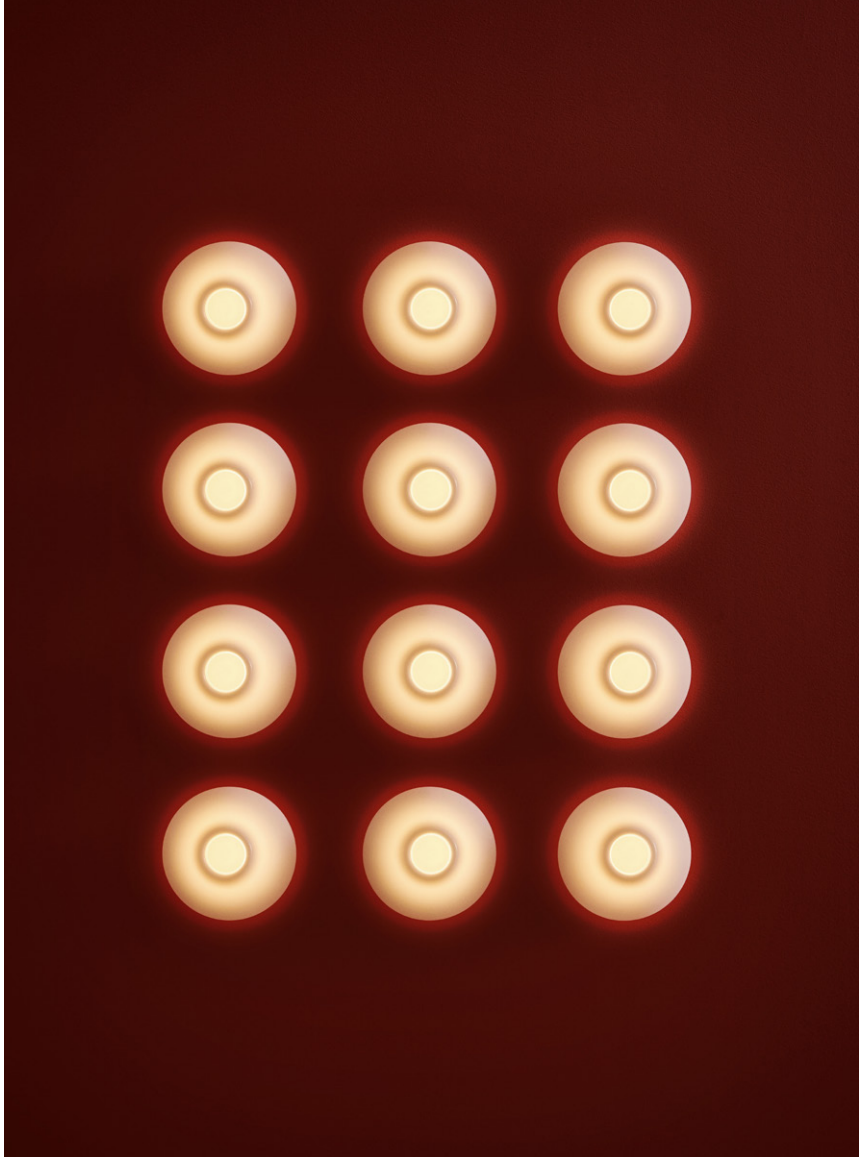

Ono Flush Mount 200

Apex Design by John Tree

In HAY's new collaboration with John Tree, the British designer offers his take on the classic Banker's Light typology, resulting in a functional lamp series that balances familiarity with a contemporary expression.

Focusing on colour as a core element of the design, Apex's distinctive folded steel shade uses vibrant tones to create a graphic contrast to the chrome-plated bases. Available in several different models – the Clip Lamp, Desk Clip Lamp, Desk Lamp, and Table Lamp – there is an Apex member that caters to every space and situation, from a task light in a workspace to an ambient lamp in the bedroom.



John Tree





Apex Clip Lamp | Luis pink



Folded steel shades

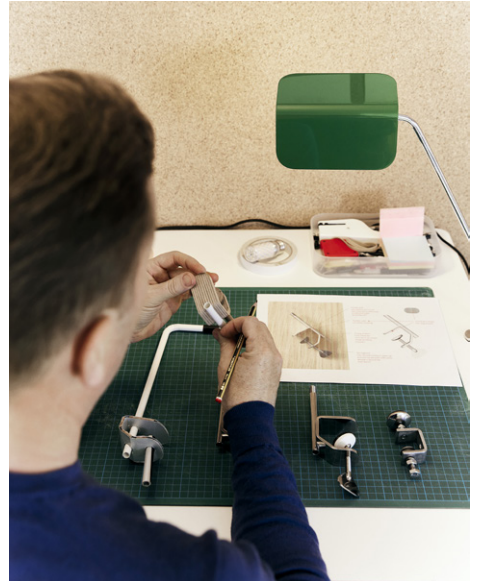

Colour is used as a key element in the folded steel shades, creating strong and colourful graphic shapes.

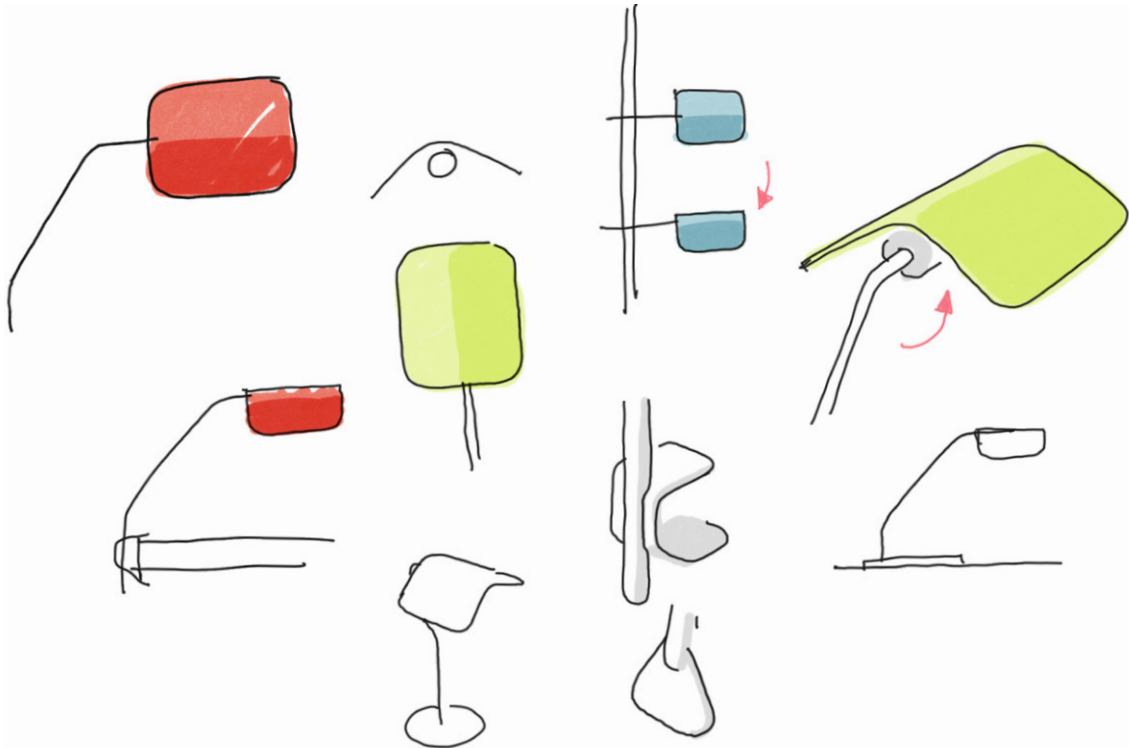

The shade is designed to rotate 360 degrees, offering a flexible lighting solution that covers a multitude of spaces and uses.



Apex Table Lamp | Luis pink



Apex Floor Lamp | Black



Apex Clip Lamp | Maroon red



Apex Table Lamp | Iron black



Apex Clip Lamp | Pastel blue



Apex Floor & Table Lamp | Iron lamp

[BACK TO CONTENT](#)

Turn On Design by Joel Hoff

Turn On is a sleek and thoughtfully engineered table lamp that blends form and function in a unified design. The faceted aluminium base shapes its identity, functioning as both the light switch and the stem supporting the spherical glass diffuser. Turning the base clockwise activates the LED light, with continued rotation gradually increasing the brightness. This intuitive mechanism is seamlessly integrated into the form, allowing users to adjust the light with a simple, tactile motion. Compact and perfectly scaled for bedside tables, shelves, or desks, the lamp is both a functional object and an expression of honest design.



Joel Hoff is an English designer working from his studio in London. His comprehensive understanding of manufacturing processes combined with his desire to inspire more responsible consumerism, drives him to design quality and functional products that last.





Turn On Table Lamp | Blue anodized







Turn On Table Lamp | Alu anodized

Noc

Design by SMITHMATTHIAS

The Noc Lamp series is a family of adaptable lights made from die-cast aluminium with a faceted shade and a smooth, powder-coated finish. It is available in three models: a universal clamp light called the Noc Clip, for use on tabletops, shelves, and headboards; the Noc Wall, featuring a cable and inline-rocker switch; and the Noc Wall Button, which conceals the cable inside the wall and features a touch-switch located on the base. This versatile series is designed for everyday use in both domestic and commercial settings.



London-based designers Jack Smith and Gemma Matthias take a responsible approach to their design work, which means that they design for the “long term.” They strive to create products that people can connect to, and that will be a pleasure to experience and use.





Noc Wall | Off white



Noc Wall | Dark grey

Brim

Design by Rui Pereira & Ryosuke Fukusada

Brim is an ambient pendant with a coloured pressed glass shade, inspired by classic glass pendants from past times. The familiar light typology has been updated in new materials and construction to optimise the function whilst retaining the pendant's timeless aesthetics. The internal sphere conceals the bulbs, which is surrounded by a distinctive fluted glass shade that enhances the light diffusion. Brim's compact size makes it ideal for hanging in clusters, as well as on its own in smaller spaces such as in hallways or over counters.

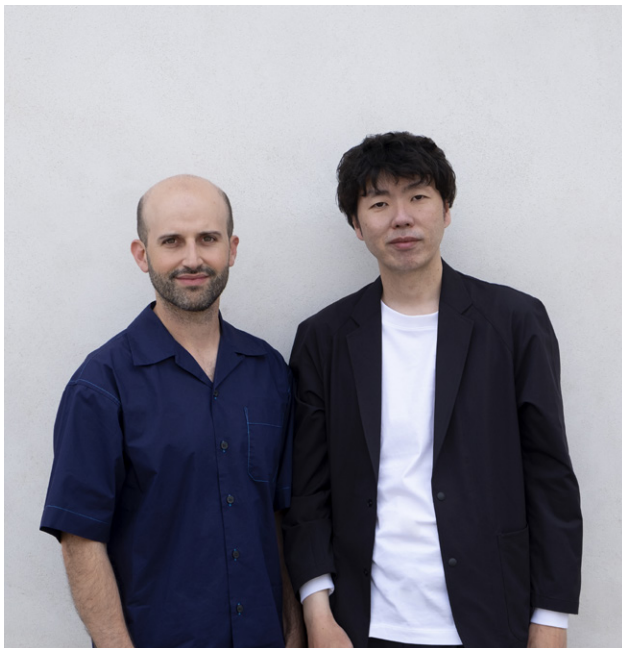

Portuguese designer Rui Pereira and Japanese designer Ryosuke Fukusada collaborate on projects that tap into their respective cultures to engage users in new and unsuspected design experiences.



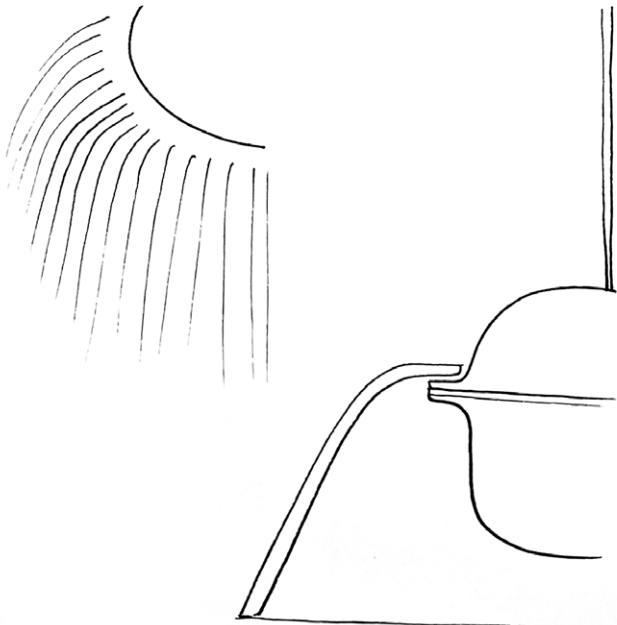
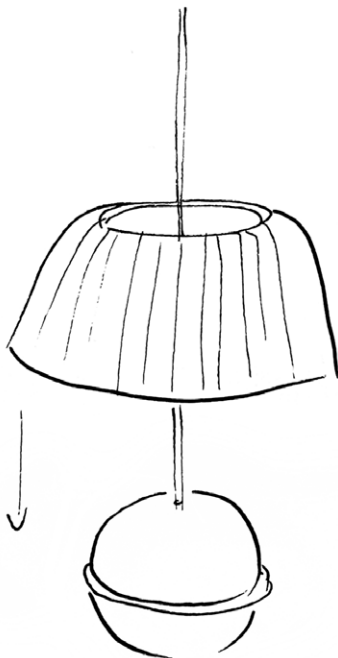
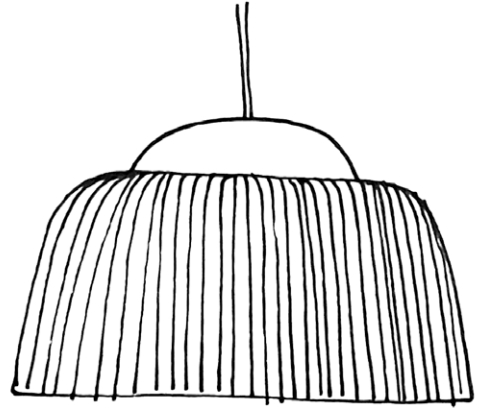
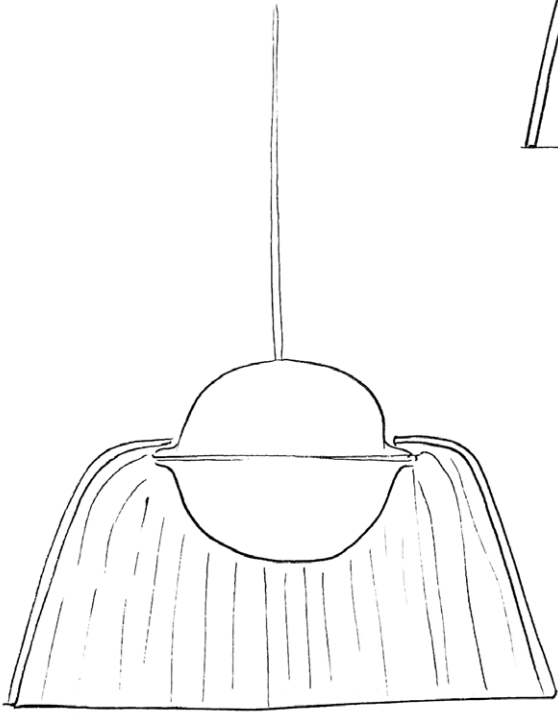
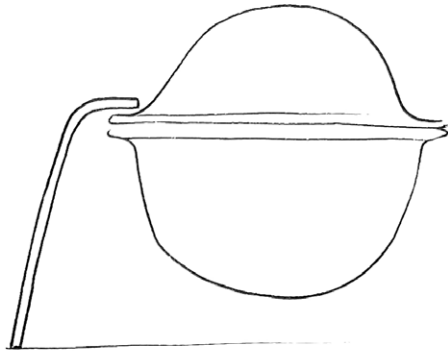

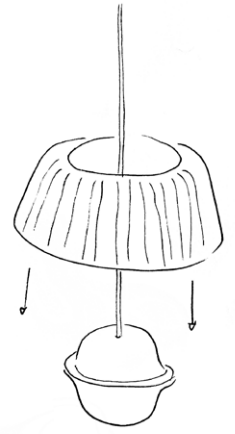
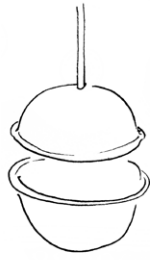



Brim Pendant 245 | Bottle green glass



Brim Pendant 245 | Smoked grey glass

Apollo Design by STUDIO 0405

Designed by STUDIO 0405, the Apollo Lamp series is a collection of elegant table, ceiling and wall lamps with a distinctive, organic expression. Comprising the Apollo Table Lamp Shade, Apollo Portable Lamp, Apollo Chandelier, and Apollo Wall Sconce, all designs have mouth-blown shades in opal glass and offer a contemporary interpretation of a classic lamp archetype. The opal glass provides an ambient glow that adds warmth and atmosphere to its surroundings, making the lamps suitable for using in a variety of private and public settings.



Nikolaj Lorentz Mentze is a Danish designer and the owner of Copenhagen-based architecture and design firm STUDIO 0405.





Apollo Portable Lamp





Apollo Wall Sconce



Apollo Table Lamp Shade

Arcs

Design by Muller Van Severen

Created for HAY by Belgian duo Muller Van Severen, Arcs reflects the designers' love of showcasing materials by focusing on simple, elemental shapes and the intensity of colour in an object. Arcs is a series of lighting designs formed from a continuous chain of curved arches that form a single element, using spatial volume to create a scalloped silhouette. Arcs is made from steel and comes in a choice of vibrant colours or with a mirror surface that reflects and magnifies the natural light. The different variants and mounting solutions give Arcs a versatile quality that makes it easy to integrate in most interior spaces.



Belgian duo Fien Muller and Hannes Van Severen, creates sculptural objects that blurs the line between art and design. For HAY, they have also designed the Two-Colour Table, Colour Cabinet, Colour Rack and Hanger, and Perforated Cabinet and the Arcs series.

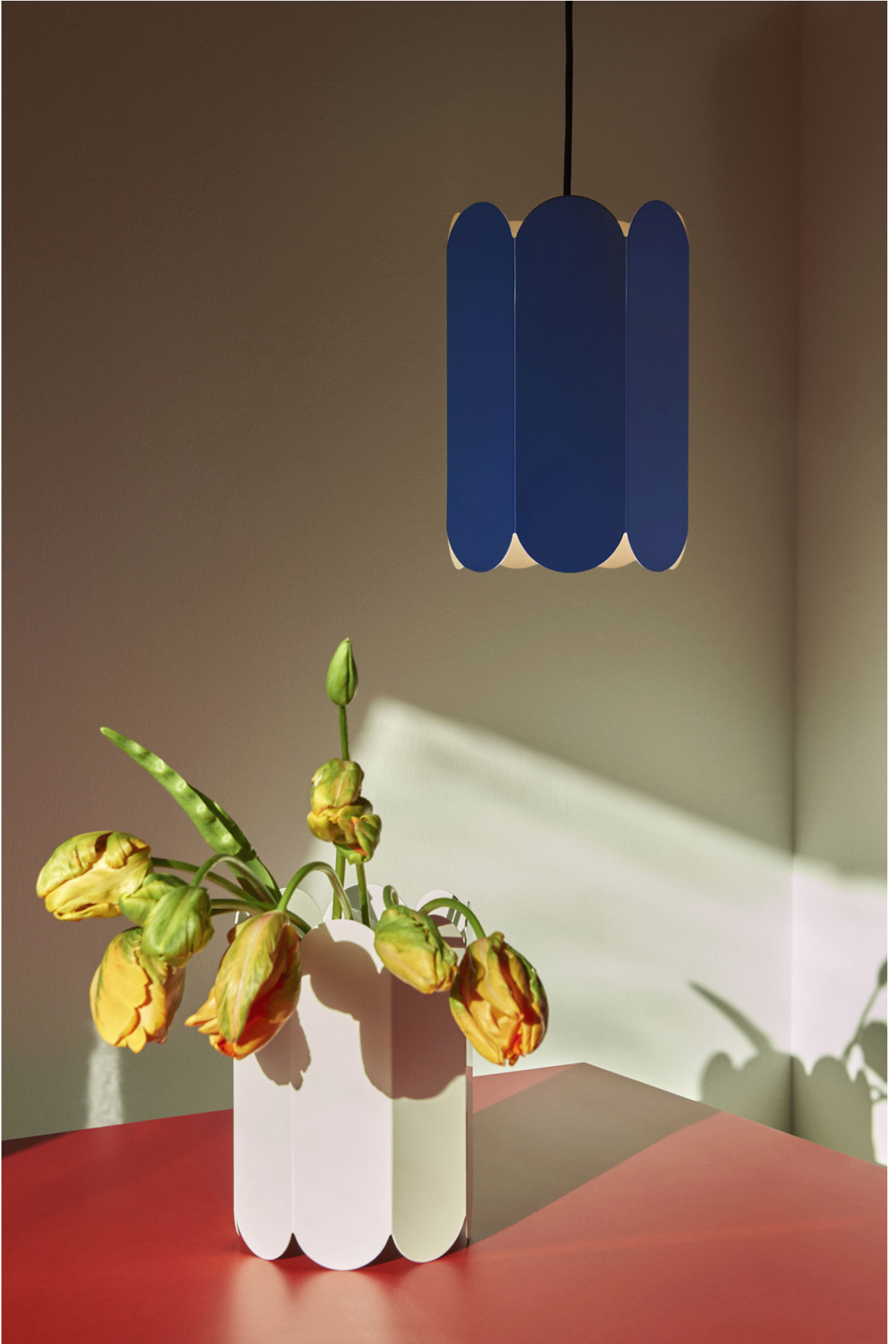



A shared love of colour and materials is often the inspiration behind many of Muller Van Severen's designs.

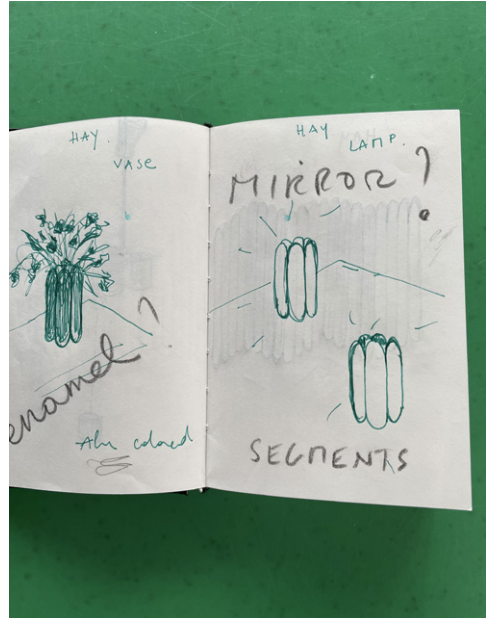

Formed from a continuous chain of curved arches that form a single element, the Arcs Shade creates a spatial volume that plays with light and shape.





Arcs Shade | Sea green





Arcs Shade | Cobalt blue



Arcs Shade | Cobalt blue

Host

Discreet in form and expression, the Host Portable Lamp occupies minimal space while offering versatile functionality. It features a magnetic base for seamless attachment to metal surfaces and includes a detachable steel foot for stable placement on non-magnetic surfaces. Rechargeable via USB-C and providing up to 16 hours of cordless illumination, it transitions effortlessly between indoor and outdoor settings, casting a warm, inviting glow in any corner of the home or garden.





An integrated magnet in the base allows attachment to metal surfaces, and a flat steel base is included for use on non-magnetic surfaces.



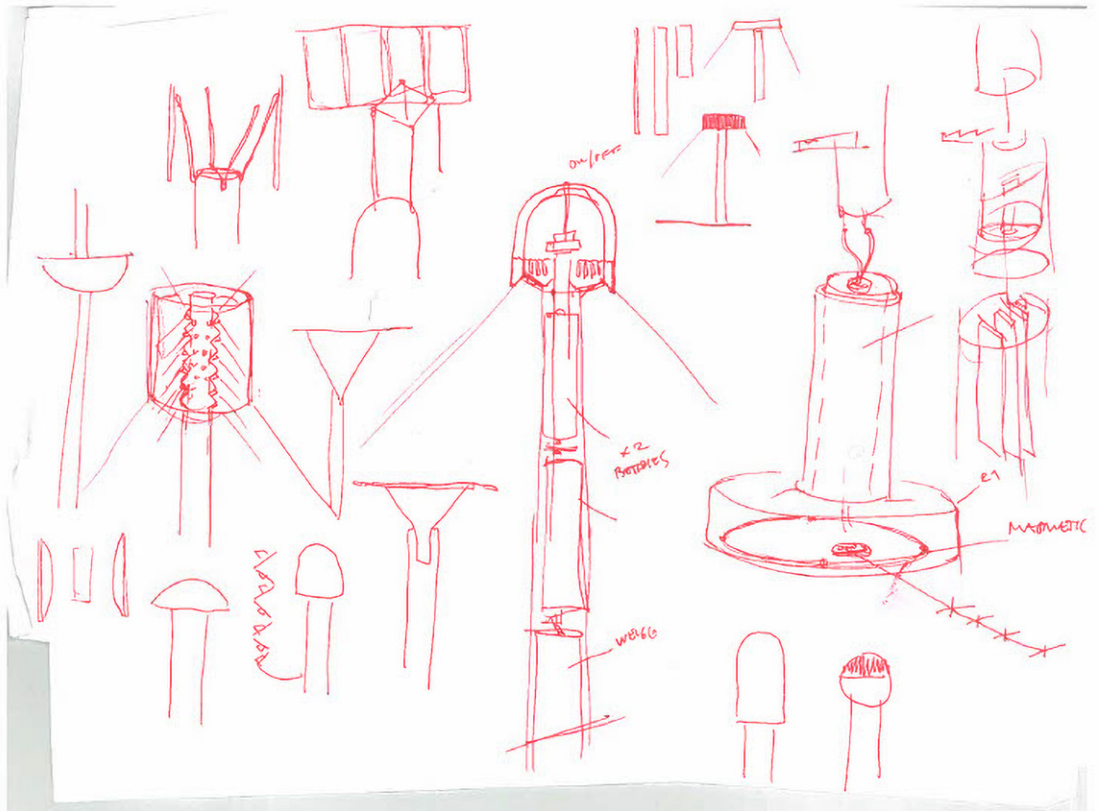



Host Portable Lamp 300 | Iron red





Host Portable Lamp Collection



Host Portable Lamp 220 | Iron red







Host Portable Lamp 220 | Cream white



Host Portable Lamp 220 & 300 | Anthracite

Mousqueton

Design by Inga Sempé

Named after the French word for carabiner, Inga Sempé's Mousqueton Portable Lamp is an outdoor LED lamp that presents a functional lighting solution with a familiar yet contemporary aesthetic. Featuring a multi-purpose hook at the top that creates multiple hanging possibilities, as well as a central hole detail, the lamp cleverly integrates technical features to amplify the functional and decorative qualities. With its solid construction and original design, Mousqueton Portable Lamp brings ambience to spontaneous and happy moments in both indoor and outdoor settings.



Inga Sempé is a French designer who lives and works in Paris. Her work is known for a lightness of touch, for a strong personality and for a particularly tactile nature. For HAY, Inga Sempé has also created the Matin Lamps.





Inga Sempé's drawings of Mousqueton

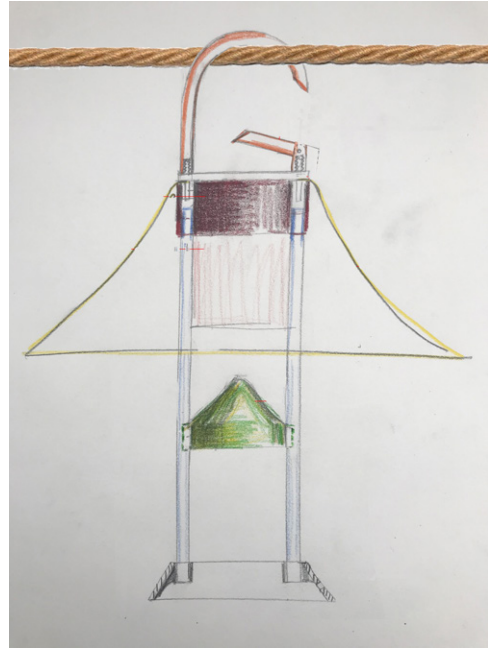

The design makes use of the multi-purpose hook to create multiple hanging possibilities, enabling the lamp to be suspended over a branch, rope or other protruding elements.





Mousqueton Portable Lamp | Oyster white



Mousqueton Portable Lamp Collection

Parade

Design by Viola Heyn-Johnsen and Jonas Trampedach

Designed by Viola Heyn-Johnsen and Jonas Trampedach, Parade Lamp is a collection of sculptural lamps with a distinctive geometric shape that changes the lamps' expression whichever angle they are turned. Comprising a square base and arched top in coloured glass, the lamps are available as a table variant with a custom, integrated LED light source, or as a portable luminaire with a battery-operated design that is easy to move around. Both models come in carefully selected sizes and colours that complement each other in height and tone, making the lights equally appealing as a group, a single lamp, or as a decorative ornament without the light switched on.



Viola Heyn-Johnsen and Jonas Trampedach are a husband-and-wife team with a shared passion for materials, objects and craftsmanship. Their design studio focuses on products, furniture and lighting.





Viola and Jonas were inspired by the desire to create an ambient light source with a sculptural quality.

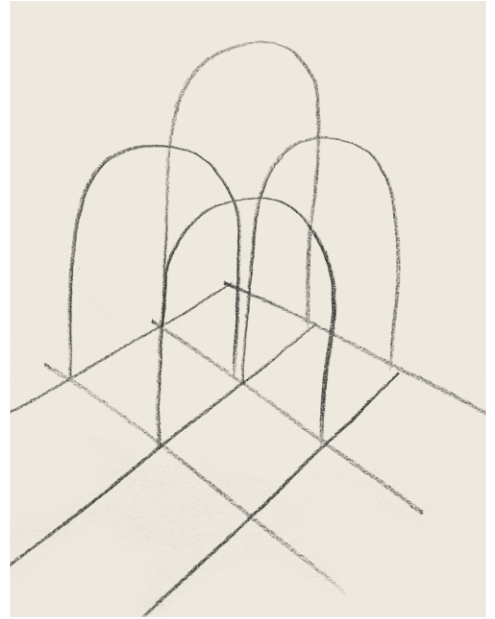

The name refers to the lamp's ability to command attention when several lamps are positioned together like a formation in a parade.





The glass geometric shape is made in carefully selected sizes and colours, designed to complement each other.



Parade Portable Lamp 240 | Shell white



Parade Table Lamp Collection

Matin

Design by Inga Sempé

Designed by Inga Sempé, the Matin lamp series offers a contemporary yet poetic design, with a construction that combines visual delicacy with physical robustness. Available in table, floor, wall and flush mounted variants, it combines steel or polished brass hardware with a pleated cotton shade in various size and colour options. The different models offer specific lighting solutions for all kinds of rooms and settings.





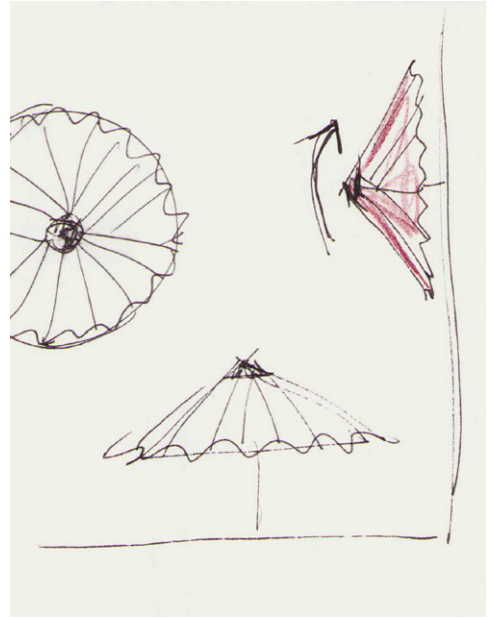

The wall lamp has an adjustable head that can easily be angled to direct light up and down.



Matin comes flat-packed and is easy to assemble. The light source is an integrated LED.



Inga Sempé's drawings of Matin.







Matin Table Lamp 300 | Placid blue shade | Mirror plated steel base



Matin Pendant 500 | Peach

Bonbon Design by Ana Kraš

Inspired by her drawings, Ana Kraš' woven Bonbon Shades are produced using an original technique to create textured, one-of-a-kind pieces. Every shade is hand woven with nylon-wool yarn around a powder-coated steel frame, resulting in individual lampshades that vary slightly in their appearance and surface aesthetic. Bonbon is available either as a table/ floor lamp or as a pendant, depending on the chosen cord set, but it stands on its own as a powerful decorative object even when the bulb is not switched on.







Bonbon Shade 310 | Petit Bleu



Bonbon Shade 320 | Grey melange



Bonbon Shade 380 | Ice cream



Pao

Design by Naoto Fukasawa

The Pao collection of lamps is an exciting collaboration with established Japanese designer Naoto Fukasawa. The Pao lamps draw on Fukasawa's "super normal" aesthetic of beautiful simplicity, everyday objects that draw on design values existing in the natural world. The inspiration for the form of these lamps came from a trip to Mongolia, where traditional nomadic tents, referred to locally as a 'Yurt' or in Japanese 'Pao', illuminated the landscape at night. Fukasawa was drawn to the glowing shape, which suggested comfort and warmth and the safety of "home," and represented a universal symbol he felt every person would find familiar in an intuitive way.

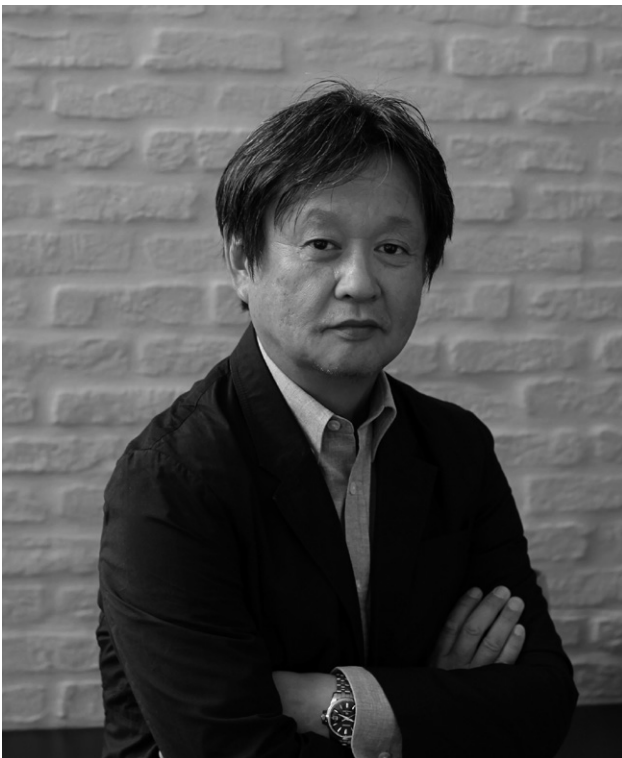

Japanese designer Naoto Fukasawa established NAOTO FUKASAWA DESIGN in 2003. His designs are known for their ability to access and communicate the true essence of an object.





The table lamp is made in opal glass, while the pendants are available in opal glass or steel with a high-gloss finish in different sizes and colours.



Named after the soft, glowing shape of traditional Mongolian Pao tents illuminated at night-time.





Pao Portable Lamp | Red



Pao Portable Lamp | Cream white



Pao Steel Pendant 470 | Cream white



Pao Glass Floor Lamp | White



Pao Steel Pendant 350 | Soft black



Pao Glass Table Lamp 350 | White

Anagram

Design by Sam Weller

Developed for HAY by British designer Sam Weller, Anagram Table Lamp combines a strong personality with a robust construction. Inspired by the idea of creating a nostalgic yet functional lamp, Sam's experiments with juxtaposing perforated steel with sheet steel led him to explore different lighting effects. The result is a generously curved, glossy shade that sits atop two split anodised aluminium legs, with the contrasting elements updating the familiar lamp typology with an original and contemporary aesthetic. Anagram's solid presence and ambient downlight make it equally suitable as a desktop-based lamp, or as a supplementary light source placed on a sideboard or windowsill.



Sam Weller is a British designer, born with a background in Industrial Design and Engineering. Sam's design work aims to be timeless and honest, focusing on a pared-back aesthetic that reflects a product's material selection and function.



Anagram Table Lamp | Charred orange



Inspired by the curves and forms of the Barbican in central London, Anagram's solid construction and generously rounded shade echo some of the architecture.

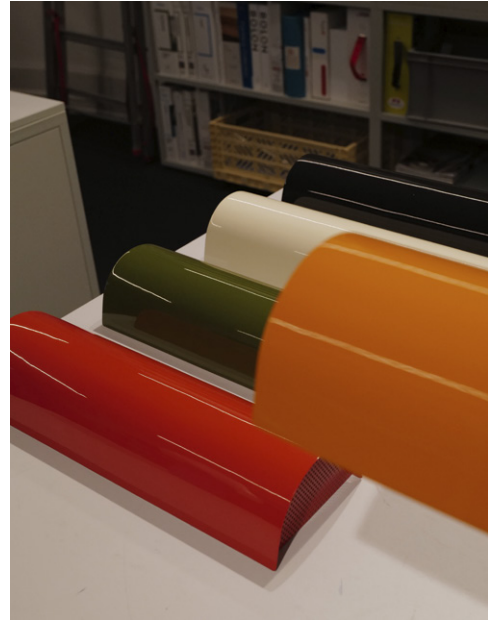
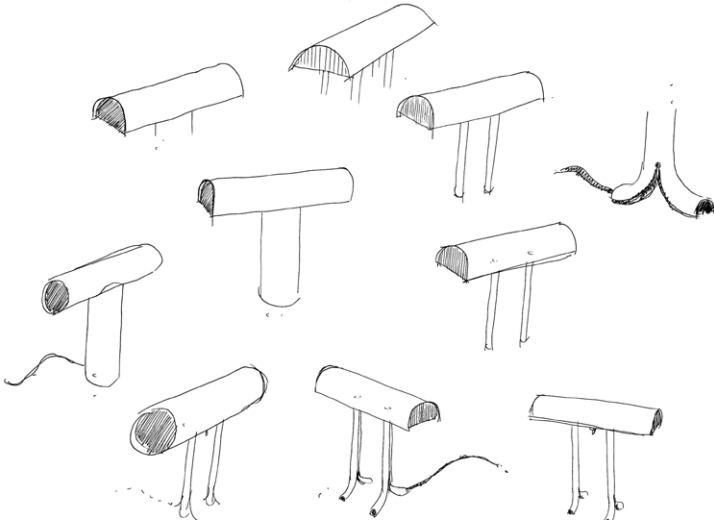

Anagram features a generously curved, glossy shade that sits a top two split anodised aluminium legs.





Anagram Table Lamp | Iron black



Anagram Table Lamp | Rice

LBM

Design by Moisés Hernández

Inspired by compatriot Luis Barragán Morfín, Moisés Hernández's LBM Table Lamp and Corner Table Lamp are influenced by the Mexican architect's innovative use of geometry, colour, and light.

The LBM lamps feature one or two folded vertical planes of sheet steel to create a similar poetic interplay of light and colour. The lamps' unique, calming atmosphere create an artistic quality that is equally appealing both when in use and switched off. The LBM series' functionality and deliberately uncluttered design makes it suitable for a wide range of spaces and uses in domestic and corporate environments.



Moisés Hernández is a Mexican designer working from his studio in Mexico City. In his work, Moisés seeks to use very simple shapes that he complements with colour and texture to bring warmth to the everyday objects that he designs.





LBM uses folded vertical sheet steel to create a poetic interplay of light and colour.

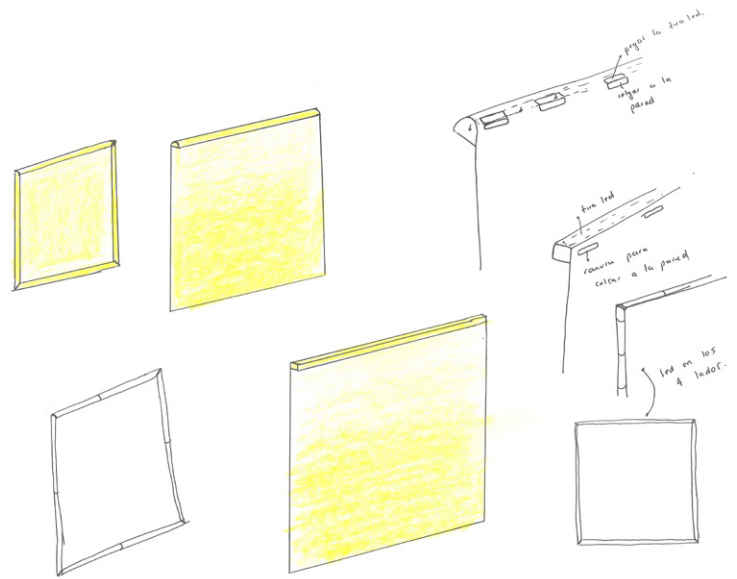
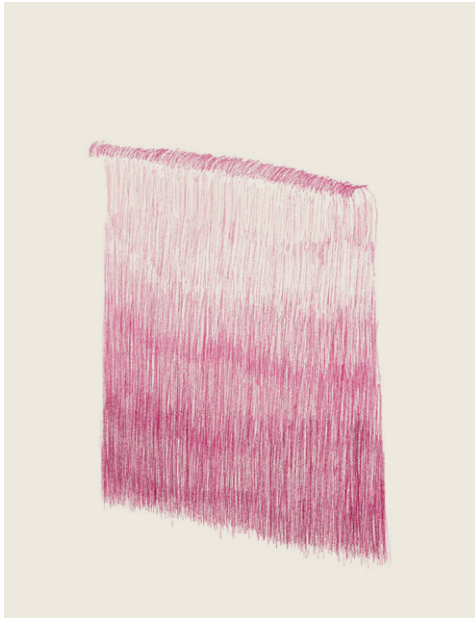

Constructed from thin planes of vertical sheet steel and using an integrated LED light with inline step dimmer.



Inspired by Luis Barragán, Moisés Hernández' LBM Table Lamp is influenced by the Mexican architect's innovative use of geometry, colour and light.

LBM Table Lamp | Tomato red





LBM Corner Table Lamp | Cream white

Factor Linear

Design by Dimitri Bähler

Designed by Swiss designer Dimitri Bähler, Factor Linear Suspension is an innovative lamp series with a rotatable tubular design. The 360-degree movement and height-adjustable linear construction enables users to create a flexible and personalised lit environment with either direct or indirect light. Easily assembled, it offers a simple plug-and-play lighting solution that requires no tools for assembly and adjustment. Made from extruded aluminium, the lamp features a dimmable integrated LED light source and is available in different colour options in different finishes. Factor is available in two variants depending on the user's needs – a warmer, more ambient light output – and another providing a cooler, more task-oriented lighting.



Dimitri Bähler is a Swiss designer who lives and works in Biel, Switzerland. His work is directed by his own sensitivity to the power of objects, and can often appear spontaneous, yet is underpinned by vigorous research.



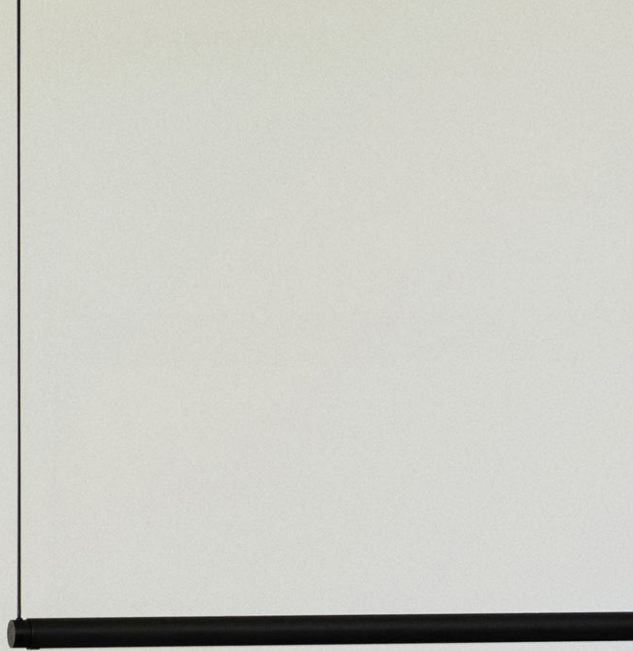







Factor Linear Suspension Lamp | Clear anodised

Paper Cube

Design by Bertjan Pot

Designed for HAY by Bertjan Pot, Paper Cube is a series of elegant and functional cubed lamps. The flat-packed design was inspired by Pot's fascination with the mechanics of constructing folded paper ornaments. The translucent cubed shade is closed on all four sides, fully encapsulating the light source and creating a soft ambient glow. Available in table and floor lamp variants, Paper Cube's clean design and warm, atmospheric light make it suitable for a variety of rooms at home, as well as restaurants, cafés and other public spaces.



Bertjan Pot is a Dutch designer working from his design studio in Rotterdam. His work reflects his curiosity for materials, with the starting point of most products arising from material research.





Paper Cube Lamp comes as a floor lamp and a table lamp, making it suitable for many different applications and environments.

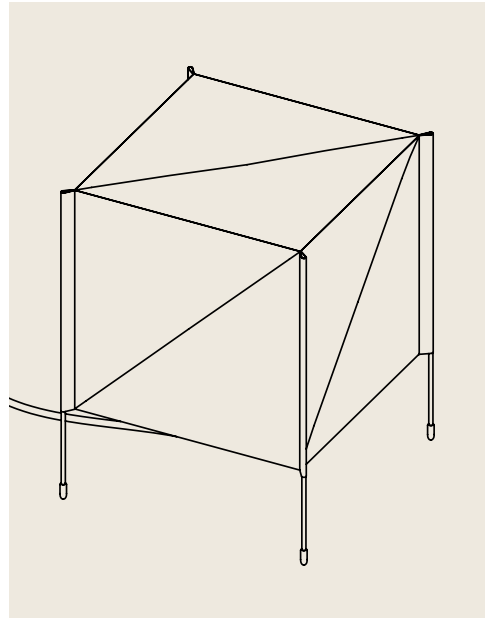

Inspired by Bertjan Pot's fascination with the mechanics of folded paper, Paper Cube Lamp has a simple yet innovative knock-down design.



The knock-down construction is easy to assemble, comprising folded recycled PET, and four wooden legs.





Paper Cube Table Lamp

Slant Design by BRANCH

Slant is the result of a collaborative project between HAY and BRANCH – a design team comprising Japanese Tsunao Nagasaki together with graduates and students of Tama Art University's Department of Integrated Design, where he used to teach. Inspired by the power of shapes and how they impact their surroundings, the Slant Lamp features a bold graphic aesthetic that takes possession of the space it occupies. Comprising a simple, slanted cylindrical form with a weighted base to keep the angle perfectly balanced, all components are concealed within to retain the clean, elemental silhouette. Slant's sculptural design and functional, directional light make it suitable for a variety of home and office settings.



BRANCH is a creative unit that explores the relationship between the world, people and objects from the multiple perspectives of art, science and design. BRANCH is based in the Department of Integrated Design at Tama Art University in Japan.





Branch design team comprises Tsunao Nagasaki, long with graduates and current students at Tama Art University's Department of Integrated Design.



A cast iron weight creates stability in the base, whilst ensuring the tilted angle remains perfectly balanced.



The team decided to scale the lamp up from the original design and create more of a statement piece.



Slant Table Lamp | Khaki green



Slant Table Lamp | White

PC Design by Pierre Charpin

Pierre Charpin's PC lamp series is a family of refined and precisely engineered multifunctional lamps, featuring a variety of designs and functions. The collection includes variants with single- and double arms, as well as free-standing, desk, clamp, suspended, and wall-mounted lights, as well as a portable outdoor model, the PC Portable. Common to all designs is the designer's intention to keep the object as visually simple as possible, making sure technical components are kept out of view.



Paris-based designer Pierre Charpin's research on form and color characterise his work and can be seen in both, limited edition products and industrial products like the PC lamp.





The PC Portable provides up to 10 hours of light, and is perfect for outdoor as well as indoor use.

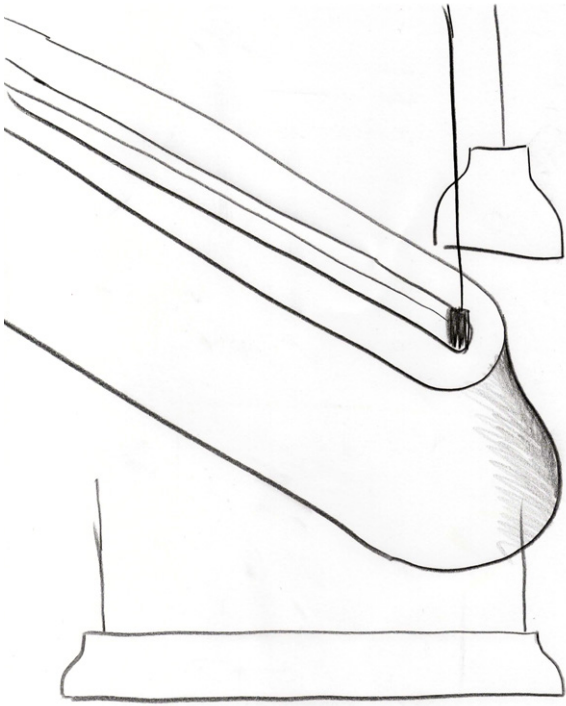

All of the lights in the iconic PC Lamp series share the line's signature tulip-shaped shade, and easily integrate into any environment.



PC Linear | Soft black





PC Table Lamp L | Soft black



BIG OBJECTS NO
ALWAYS SILENT
NATHALIE SUPASQUE
AN EXHIBITION OF WORK
CURATED BY LUCA LO
-TO-
KUNSTHALLE WIE
MUSEUMS QUARTIER
15/7 → 13/1
2016.

PC Pendant L | Soft black





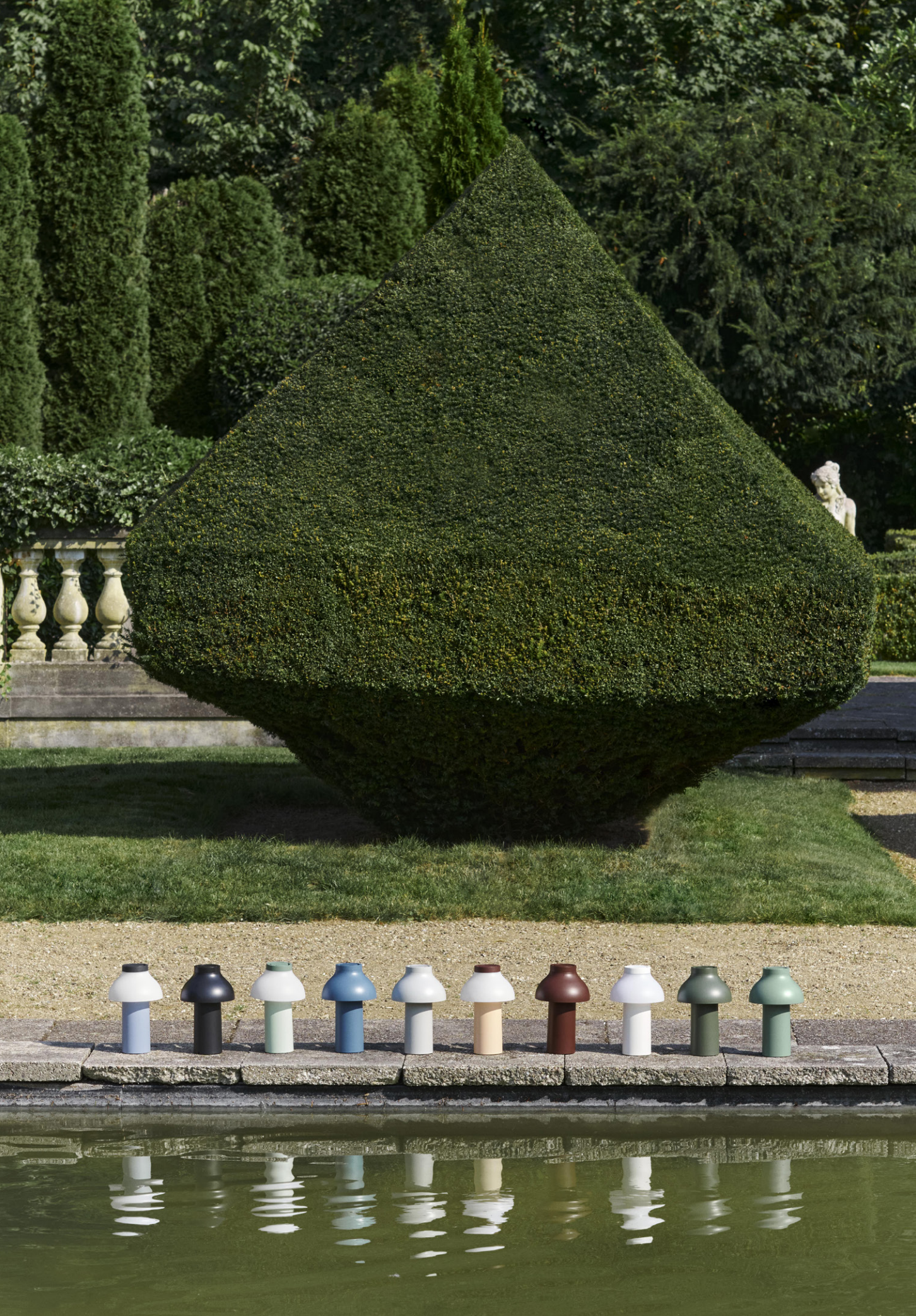



PC Portable Lamp | Cool grey

Nelson Bubble For Herman Miller, available from HAY Design by George Nelson

Designed by pioneering American designer George Nelson in 1947, the Bubble Lamp represents an iconic moment in the history of design. Produced using a technique that was extremely innovative at the time, these elegant, floating orbs are lightweight and versatile. They are available from HAY in both pendant and wall-lamp styles and an assortment of sizes and shapes, enabling our customers to enjoy the soft glow of Nelson's revolutionary design in their own homes.



George Nelson was one of the most influential figures in the crucial early period of modern design. Courtesy Hermann Miller inc.



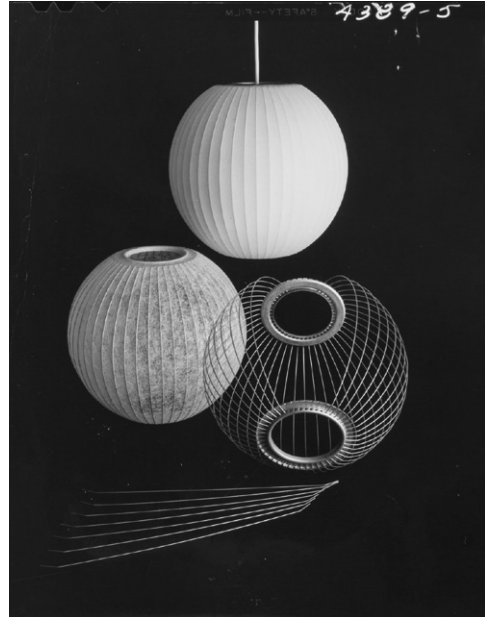

Designed by pioneering American designer George Nelson in 1947, the Bubble Lamp signaled a revolution in the Modernist lighting industry.



Photo by Leslie Schwartz, © 2013 Eames Office LLC (eamesoffice.com). All rights reserved.

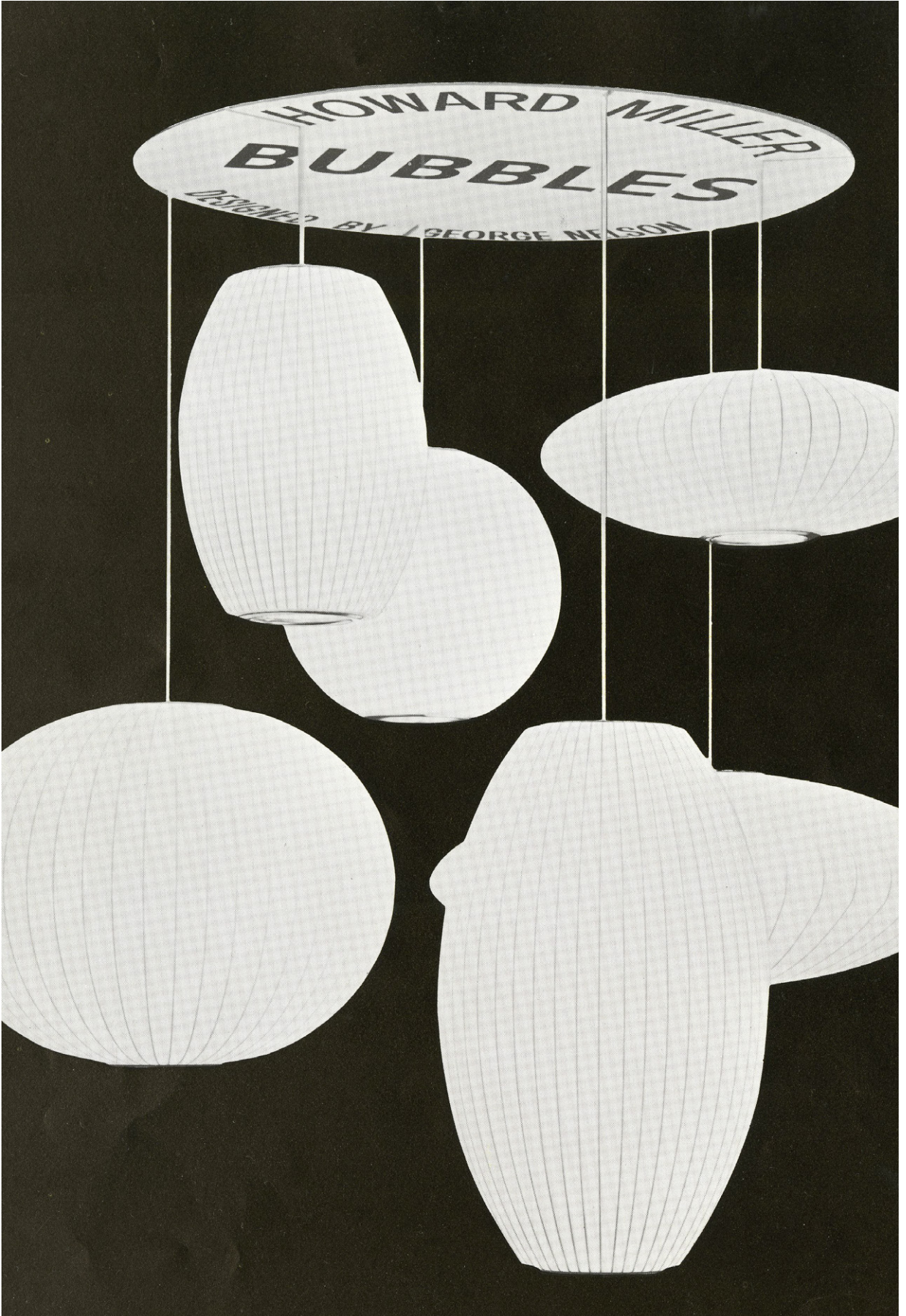

George Nelson, Courtesy Hermann Miller inc.



Nelson Saucer Bubble Pendant





Nelson Roll Bubble Pendant



Common

Fusing simple design language with a classic archetype, the Common Table and Floor Lamp series comprises a classic rice paper lantern design atop a slim stem and base. Designed as two separate elements that can be used apart or together, they form a harmonious pair, with the airy paper shade complementing the minimalist base perfectly. The lamp base is available as a table and floor variant, which supports the shade to create a soft glow that adds warmth and atmosphere to any space in the home.







Paper Shade for Common Lamp Base | Peach



Common Table & Floor Lamp

Common Cord Set Design by HAY

The Common Cord Set is a versatile cord set with components in matching colours. Available in two variants – for pendants and table lamps – the set is compatible with numerous HAY shades and can also be used alone with an E27 bulb. Both models are available in numerous colour options to create a functional and colourful lighting solution. Please note that bulbs are not included.





Common Table Cord Set





Common Pendant Cord Set

Marselis

Design by kaschkasch

Inspired by the bent tubing around local Danish street signs, design duo kaschkasch has created a family of table and floor lamps sharing the same arched silhouette. The light source comes from a tilting circular disc, which can be adjusted to create both an indirect ambient and a direct task-light beam. The lamp body is crafted from powder-coated, die-cast aluminium and steel, and the light source is an opalescent, injection-moulded polycarbonate lens that conceals a flat panel of light. Both lamp designs are available in different colours and are suitable for a variety of private and corporate settings.



Design studio kaschkasch was founded in 2011 by the two Germans Florian Kallus and Sebastian Schneider. The duo works in furniture, lighting design and art direction for several national and international clients.





kaschkasch was inspired by the bent tubing around street signs in their creation of the Marselis lamp.





Marselis Floor Lamp | Ash grey



30 Degrees

Design by Johan Van Hengel

30 Degrees is a lightweight shade made of laminated oak veneer. The seamless surface is achieved by aligning the ends of semicircular veneer sheets at a 30-degree angle, so the inside cone and internal angle always maintain a 30-degree relationship. The layering of the conical veneer creates a solid shade that is opaque, characterized by its harmonious woodgrain pattern. Rich in tactility, the series express an organic yet elegant aesthetic.



Johan van Hengel is a Rotterdam-based product designer with a technical background in industrial design. In 2013, Johan launched his own studio with focus on furniture, lighting, and everyday objects.





30 Degrees | S



Dimensions

Ceiling Lamps



Ava Cone Pendant
500 | Ø50 x H18,5 cm

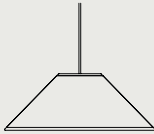

Ava Cone Pendant
600 | Ø50 x H18,5 cm



Compass Pendant
260 | Ø26 x H16 cm



Compass Pendant
430 | Ø43 x H26,5 cm

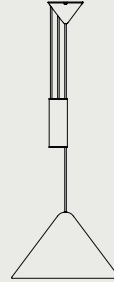

Compass Adjustable Pendant
430 | Ø43 x H26,5 cm



PC Pendant
M | Ø40 x H20,5 cm

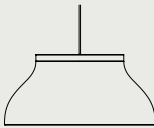

PC Pendant
L | Ø60 x H28 cm



Bouy Glass Pendant
200 | Ø20 x H20,5 cm

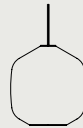

Bouy Glass Pendant
300 | Ø30 x H32 cm



Brim Pendant
Ø24,5 x H12,3 cm



Pao Steel Pendant
230 | Ø23 x H10 cm



Pao Steel Pendant
350 | Ø35 x H14,50 cm

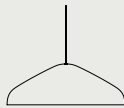

Pao Steel Pendant
470 | Ø47 x H16,25 cm



Pao Glass Pendant
350 | Ø35 x H14,50 cm

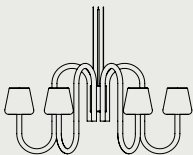

Apollo Chandelier 745
Ø74,5 x H36 cm

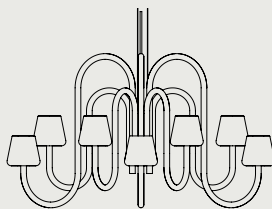

Apollo Chandelier 1065
Ø106,5 x H54 cm

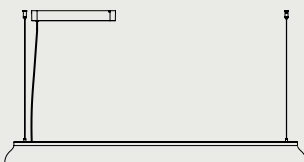

PC Linear Lamp
W120 X D14 x H10 cm

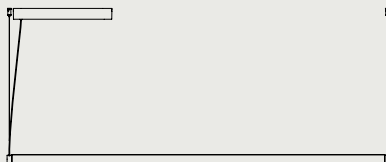

Factor Linear Suspension Lamp
W152 X D3,5 x H3,5 cm



Nelson Bubble
Ball Pendant
S | Ø32,5 X H30,5 cm



Nelson Bubble
Ball Pendant
M | Ø48,5 X H39,5 cm



Nelson Bubble
Ball Pendant
L | Ø68 X H59,5 cm

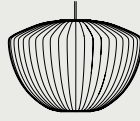

Nelson Bubble
Apple Pendant
M | Ø53,5 X H37 cm



Nelson Bubble
Pear Pendant
S | Ø33 X H32 cm

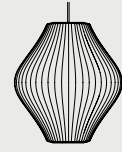

Nelson Bubble
Pear Pendant
M | Ø43 X H48 cm



Nelson Bubble
Saucer Pendant
S | Ø44,5 X H18 cm

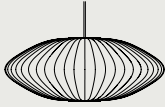

Nelson Bubble
Saucer Pendant
M | Ø63,5 X H25,5 cm

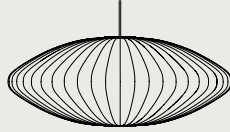

Nelson Bubble
Saucer Pendant
L | Ø89 X H35,5 cm

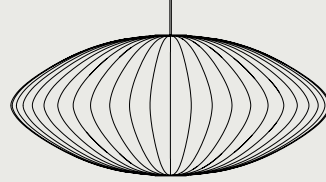

Nelson Bubble
Saucer Pendant
XL | Ø127 X H56 cm



Nelson Bubble
Saucer Crisscross
Pendant
S | Ø44,5 X H15 cm



Nelson Bubble
Saucer Crisscross
Pendant
M | Ø63,5 X H24 cm



Nelson Bubble
Cigar Crisscross
Pendant
S | Ø26,5 X H35,5 cm



Nelson Bubble
Cigar Crisscross
Pendant
M | Ø33 X H53,5 cm



Nelson Bubble
Pear Crisscross
Pendant
S | Ø33 X H32 cm



Nelson Bubble
Pear Crisscross
Pendant
M | Ø43 X H48,5 cm



Nelson Bubble
Ball Crisscross
Pendant
S | Ø32,5 X H30,5 cm



Nelson Bubble
Ball Crisscross
Pendant
M | Ø48,5 X H39,5 cm



Nelson Bubble
Propeller Pendant
M | Ø52 X H38 cm



Nelson Bubble
Lantern Pendant
S | Ø28 X H 26,5 cm



Nelson Bubble
Roll
M | Ø42 X H39 cm



Nelson Bubble
Angled Sphere
S | Ø35,5 X H24 cm

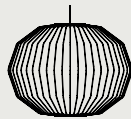

Nelson Bubble
Angled Sphere
M | Ø49,5 X H38,5 cm

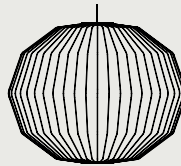

Nelson Bubble
Angled Sphere
L | Ø71 X H56 cm

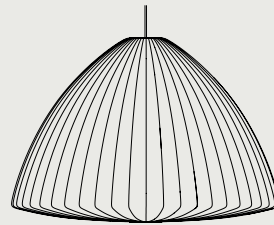

Nelson Bubble
Bell Pendant
XL | Ø106,5 X H73,5 cm



Nelson Bubble
Cigar Pendant
S | Ø26,5 X H35,5 cm

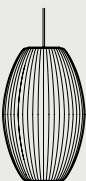

Nelson Bubble
Cigar Pendant
M | Ø33 X H53 cm



Nelson Bubble
Cigar Pendant
L | Ø38 X 84 cm



Nelson Bubble
Cigar Pendant
XL | Ø47,5 X H127 cm

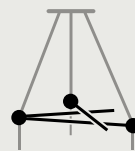

Nelson Fixture
For Triple Bubble Lamp
Ø105 cm

Dimensions

Ceiling Lamps



Matin Pendant
300 | Ø30 X H11,5 cm

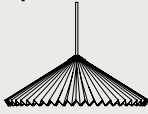

Matin Pendant
380 | Ø38 X H14 cm

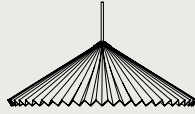

Matin Pendant
500 | Ø50 X H18 cm



Matin Flush Mount
380 | W38 X D38 x H16 cm



Matin Flush Mount
500 | W50 X D50 x H20 cm

Wall Lamps



Ava Square Wall Lamp
W15,5 x D8,5 x H20,5 cm



Apex Wall Lamp
W14 x D9,5 x H16 cm



Arcs Wall Switch
W17 x D13 x H25 cm



Arcs Wall Sconce
W17 x D13 x H25 cm



Matin Wall Lamp
300 | W30 X D25 x H30 cm



Matin Wall Lamp
380 | W38 X D25 x H38 cm



Ono Flush Mount
200 | Ø20 x D13,5 cm



Ono Flush Mount
350 | Ø35 x D13,5 cm



Noc Wall Button Lamp
W11,8 X D22 X H14 cm



Noc Wall Lamp
W11 X D22 X H14 cm

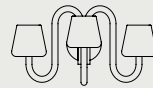

Apollo Wall Sconce Lamp
W48 X D20 x H26,5 cm

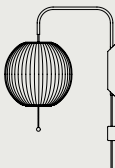

Nelson Ball Wall Sconce Cabled
S | Shade Ø30,35 X H30,5 cm
Total D53,5 cm

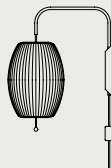

Nelson Cigar Wall Sconce Cabled
S | Shade Ø26,5 X H35,5 cm
Total D50,5 cm

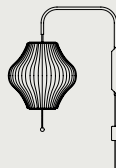

Nelson Pear Wall Sconce Cabled
S | Shade Ø33 x H32 cm
Total D53 cm



Nelson Saucer Wall Sconce Cabled
S | Shade Ø44,5 X H18 cm
Total D59 cm

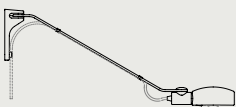

Cupola Wall Lamp
W11 x D60,7 x H13,4 cm

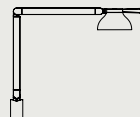

PC Double Arm w. Wall Bracket
W14 X D55 X H45 cm

Table Lamps



Ava Pyramid Table Lamp
290 | W29 x D29
H32 cm



Ava Pyramid Table Lamp
450 | W45 x D45
H50 cm

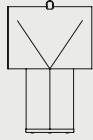

Aplat Table Lamp
440 | W28 x D17,5
H44 cm

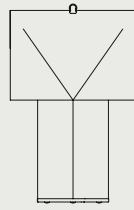

Aplat Table Lamp
660 | W42 x D26
H66 cm



Buoy Table Lamp
200 | Ø20 x H23,5 cm

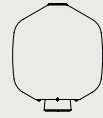

Buoy Table Lamp
300 | Ø30 x H36 cm



LBM Table Lamp
W22,5 x D10,5 x H22,5 cm



LBM Corner
W25 x D25 x H25 cm



Turn On
Ø10 X H19,5 cm



Parade Table Lamp
160 | W15,5 x
D15,5 x H16 cm



Parade Table Lamp
240 | W15,5 x
D15,5 x H24 cm



Parade Table Lamp
320 | W15,5 x
D15,5 x H32 cm



Drome Table Lamp
W31,5 x D22 x H22 cm

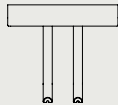

Anagram Table Lamp
Ø36,5 x H32,5 cm



Matin Table Lamp
300 | Ø30 x H38 cm



Matin Table Lamp
380 | Ø38 x H52 cm

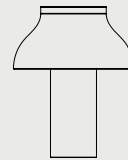

PC Table Lamp
L | Ø40 x H50 cm



Paper Cube Table Lamp
W21,5 x D21,5 x H30,5 cm



Slant Table Lamp
W23,5 x D24,5 x H28 cm



Marselis Table Lamp
W10 X D20 X H38 cm



Cupola Desk Lamp
W16 x D31,8 x H40,8 cm



Apex Table Lamp
W19 X D16 X H38 cm

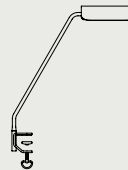

Apex Desk Clip Lamp
W14 X D36,5 X H43 cm

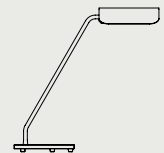

Apex Desk Lamp
W16 X D39 X H38 cm



Common Table Lamp Base
Ø22 x H39 cm

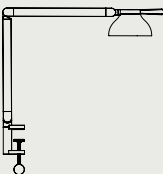

PC Double Arm w. Clamp
W14 X D55 X H60,5 cm

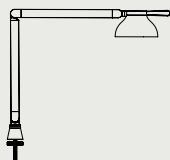

PC Double Arm w. Table Insert
W14 X D55 X H42,5 cm

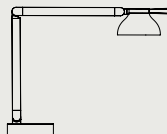

PC Double Arm w. Table Base
W14 X D55 X H42 cm

Dimensions

Clip Lamps



Cupola Clip Lamp
W11 x D14 x H29,5 cm

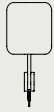

Apex Clip Lamp
W14 x H27,5 cm

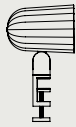

Noc Clip Lamp
W10 X D14 X H22 cm

Floor Lamps

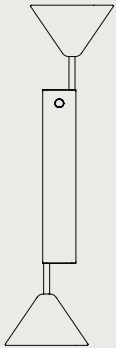

Twist
Floor Lamp
Ø36 x H115-200 cm

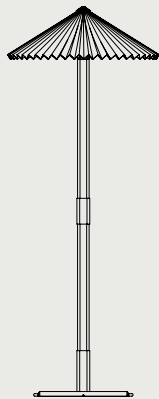

Matin
Floor Lamp
500 | Ø50 x H129 cm

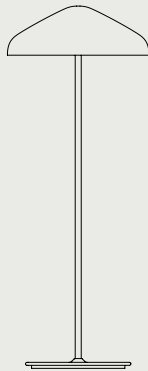

Pao Steel
Floor Lamp
470 | Ø47 x H120 cm

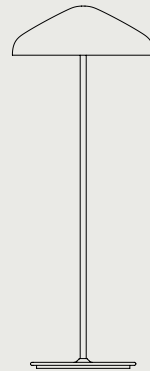

Pao Glass
Floor Lamp
470 | Ø47 x H120 cm



Common Floor
Lamp Base
Ø35 x H129 cm



Marselis
Floor Lamp
W17,5 X D21,2 X H126 cm

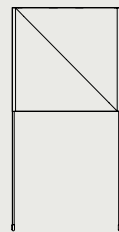

Paper Cube
Floor Lamp
W36 X D36 X H74 cm

Portable Lamps



Host
Portable
Lamp
220 |
Ø10 x H22 cm



Host
Portable
Lamp
300 |
Ø10 x H30 cm



Parade
Portable
Lamp
160 | H16 x W15,5
x D15,5 cm



Parade
Portable
Lamp
240 | H24 x
W15,5 x D15,5 cm



Mousqueton
Portable
Lamp
Ø19,5 x H30,5 cm



PC
Portable
Lamp
Ø14 x H22 cm



Apollo
Portable
Lamp
Ø12,5 x H22 cm



Pao
Portable
Lamp
Ø23 X 23 cm

Lamp Shades

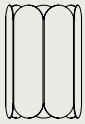

Arcs Shade
W20 x D20 x H30 cm

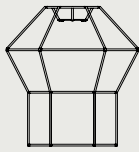

Bonbon Shade
310 | W32 X D32 x H38 cm

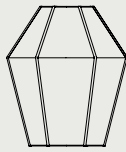

Bonbon Shade
320 | W32 X D32 x H38 cm

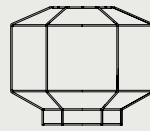

Bonbon Shade
380 | W38 X D38 x H32 cm

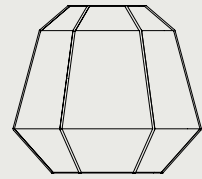

Bonbon Shade
500 | W50 X D50 x H46,6 cm

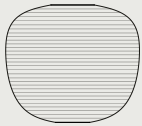

Paper Shade
for Common
Lamp Base
Peach
Ø42 x H39 cm



Paper Shade
for Common
Lamp Base
Oblong
Ø24 x H50 cm



30 Degrees
Shade
S | Ø24 x H17 cm

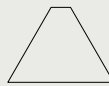

30 Degrees
Shade
M | Ø33,5 x H25 cm

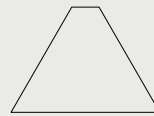

30 Degrees
Shade
L | Ø45 x H35 cm



Apollo Table
Lamp Shade
Ø25 x H38 cm

Cord Sets



Common Pendant
Cord Set
Ø12 cm
Cord length 400 cm

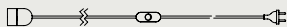

Common Table
Cord Set
Ø4,5 cm
Cord length 240 cm



HAY