

TOLIX

CATALOGUE RAISONNÉ
Presentation of the editions and the reeditions 2024

CATALOGUE RAISONNÉ
[ed. 2024]

[FR] L'histoire de Tolix s'étend sur près d'un siècle, façonnée par des esprits visionnaires, des artisans habiles et une passion indéfectible pour la création de meubles intemporels. L'essence même de cette Manufacture repose sur une fusion unique entre tradition et innovation, laissant une empreinte indélébile dans le domaine du mobilier design.

En 1935, Paris, éblouissante de modernité, se prépare à accueillir le monde pour la 24^e Exposition Universelle. Face à cet événement d'envergure mondiale, la nécessité de renouveler le mobilier urbain se fait sentir. C'est dans ce contexte que la Maison Silly et Lallemand, consciente de l'importance de l'événement, sollicite l'expertise des «Établissements X. Pauchard – Sièges Tolix» pour élaborer un mobilier à la hauteur des ambitions de cette grande exposition. De cette collaboration naît la chaise «AX» et le fauteuil «EX», rebaptisés ultérieurement «T37» en hommage à cette année phare.

Mais l'histoire ne s'arrête pas là. À la suite du décès de Xavier, son fils Jean reprend le flambeau et poursuit l'œuvre de son père avec un sens aigu de l'innovation. C'est sous sa direction que naissent des icônes telles que la table 55 ou le fauteuil A56, emblèmes toujours présents dans les catalogues de Tolix.

Jean Pauchard poursuit le développement de la société en répondant à des appels d'offres publics, notamment pour l'Université

de Dijon. De cette opportunité naît la chaise «UD», une alliance parfaite entre fonctionnalité et esthétisme.

Aujourd'hui, Tolix connaît une renaissance transformative sous la direction visionnaire du duo entrepreneurial, Antoine Bejui et Emmanuel Diemoz. Cette renaissance de la Manufacture passe également par l'établissement d'une direction artistique interne et d'une identité visuelle rafraîchie, méticuleusement élaborée par l'Atelier Franck Durand. Ce mouvement stratégique reflète l'engagement de Tolix non seulement à préserver son patrimoine, mais aussi à se propulser dans un paysage de design dynamique et contemporain.

Au-delà des pièces intemporelles présentées dans son catalogue existant, Tolix trace une voie vers l'avenir en dévoilant un programme qui revisite et réédite des modèles plus anciens de ses archives étendues.

Ce voyage dans le passé ne se limite pas simplement à la nostalgie; au contraire, les pièces patrimoniales sont soigneusement réimaginées pour répondre aux exigences fonctionnelles et stylistiques contemporaines. Une fusion harmonieuse de matériaux est à l'avant-garde, où le bois converge avec le métal, créant une symphonie de confort et d'esthétisme dans le mobilier.

L'aventure Tolix est une célébration du design, de l'artisanat et de l'innovation, et nous sommes honorés de vous la présenter.

[EN] The story of Tolix spans nearly a century, shaped by visionary minds, skilled craftsmen, and an unwavering passion for creating timeless furniture. The very essence of this Manufacture rests on a unique fusion of tradition and innovation, leaving an indelible mark in the field of furniture design.

In 1935, Paris, radiating with modernity, prepared to host the world for the 24th Universal Exposition. Faced with this globally significant event, the need to renew urban furniture became evident. It is in this context that Maison Silly and Lallemand, aware of the event's importance, sought the expertise of the “Établissements X. Pauchard – Sièges Tolix” to create furniture worthy of the ambitions of this grand exhibition. This collaboration gave birth to the “AX” chair and the “EX” armchair, later renamed “T37” in homage to that pivotal year.

But the story doesn't end there. Following Xavier's death, his son Jean took up the mantle and continued his father's work with a keen sense of innovation. Under his leadership, icons like the “55” table or the “A56” armchair were born, emblems still present in Tolix's catalogs.

Jean Pauchard furthered the company's development by responding to public

tenders, notably for the University of Dijon. From this opportunity arose the “UD” chair, a perfect blend of functionality and aesthetics.

Today, Tolix is experiencing a transformative renaissance under the visionary leadership of the entrepreneurial duo, Antoine Bejui and Emmanuel Diemoz. This renaissance involves establishing an internal artistic direction and a meticulously crafted refreshed visual identity by the Atelier Franck Durand. This strategic move reflects Tolix's commitment not only to preserving its heritage but also to propelling itself into a dynamic and contemporary design landscape.

Beyond the timeless pieces presented in its existing catalog, Tolix is forging a path to the future by unveiling a program that revisits and reissues older models from its extensive archives. This journey into the past is not limited to mere nostalgia; on the contrary, heritage pieces are carefully reimaged to meet contemporary functional and stylistic demands. A harmonious fusion of material takes center stage, where wood converges with metal, creating a symphony of comfort and aesthetics in furniture.

The Tolix adventure is a celebration of design, craftsmanship, and innovation, and we are honored to present it to you.

T37.COLLECTION [ed. 2024]

L'histoire de la chaise T37 prend racine en 1935, lorsque la ville de Paris lance des appels d'offres publics en préparation de la 24^e Exposition Universelle de 1937. Plus de 12 000 chaises et fauteuils sont produits pour aménager plus de cent hectares de jardins publics.

À l'aube de ses 90 ans, la chaise T37 est rééditée, et agrémentée de nouvelles créations imaginées par le Studio Tolix. Ainsi de la table monacale aux tables rondes, toutes au plateau ourlé à la main par les artisans de la Manufacture, la collection T37, avec ses lignes affirmées et ses silhouettes contemporaines, retrouve sa place dans les jardins et intérieurs modernes. Une palette de couleurs chaudes lui est dédiée pour renforcer son identité distinctive.^[FR]

The history of the T37 chair dates back to 1935 when the city of Paris issued public tenders in preparation for the 24th Universal Exposition of 1937. Over 12,000 chairs and armchairs were produced to furnish more than a hundred hectares of public gardens.

At the dawn of its 90 years, the T37 chair is reissued and complemented by new creations imagined by Studio Tolix. From the monastery table to round tables, all with a hand-hemmed tabletop by the artisans of the Manufacture, the T37 collection, with its bold lines and contemporary silhouettes, regains its place in modern gardens and interiors. A palette of warm colors is dedicated to it to reinforce its distinctive identity.^[EN]

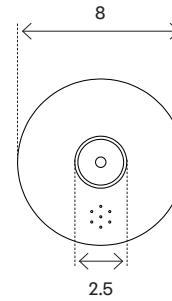
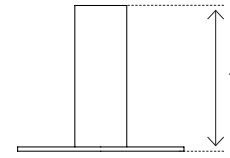

Candle Holder S with Beeswax candle, *Pure White* color

CANDLE HOLDER S WITH BEESWAX CANDLE

designer:	Studio Tolix	creation:	2024
guarantee:	two years	fabrication:	handmade in Autun, France
dimensions:	D.8 ^[CM] H.7 ^[CM]	material:	steel
weight:	0.12 ^[KG]	finition:	available page 300
candle:	H.28 ^[CM]	use:	indoor outdoor
highlights:	delivered with a beeswax candle	assembly:	assembled



Candle Holder L with Beeswax candle, *Pure White* color

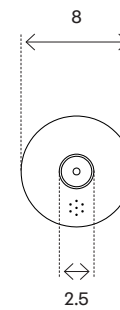
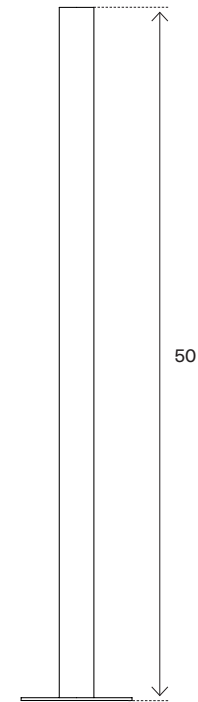

CANDLE HOLDER L WITH BEESWAX CANDLE

designer:	Studio Tolix	creation:	2024
guarantee:	two years	fabrication:	handmade in Autun, France
dimensions:	D.8 ^[CM] H.50 ^[CM]	material:	steel
weight:	0.46 ^[KG]	finition:	available page 300
candle:	H.28 ^[CM]	use:	indoor outdoor
highlights:	delivered with a beeswax candle	assembly:	assembled



T37 Chair, Pure White color

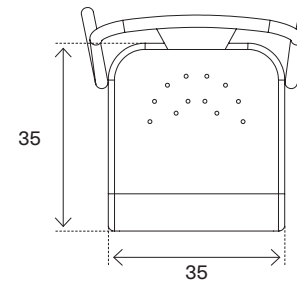
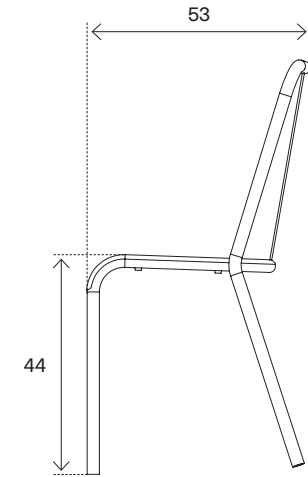
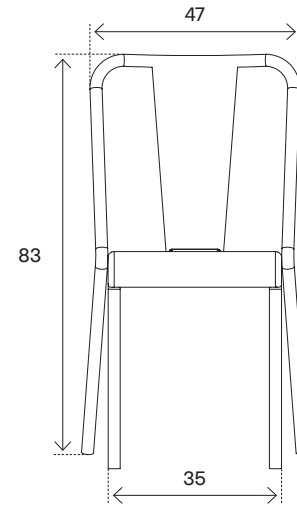

T37 CHAIR

designer:	Xavier Pauchard	creation:	1937
guarantee:	two years	fabrication:	handmade in Autun, France
dimensions:	W.47 [CM] D.53 [CM] H.83 [CM]	material:	steel
seat:	W.35 [CM] D.35 [CM] H.44 [CM]	finition:	available page 300
weight:	5,2 [KG]	use:	indoor
highlight:	stackable up to 4 units	assembly:	assembled



T37 Chair, Raw Steel Varnished

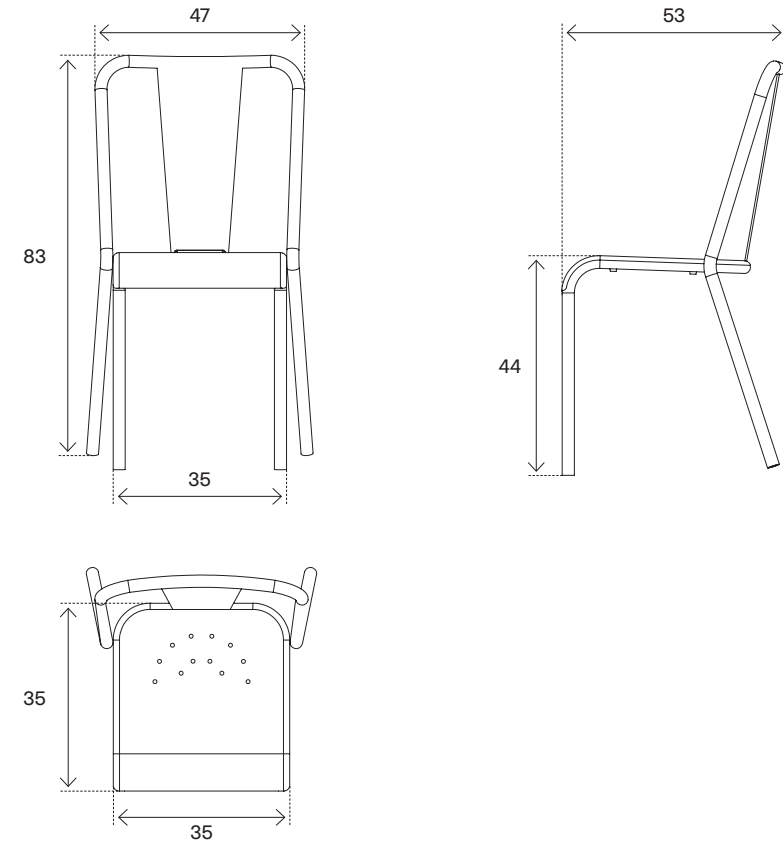

T37 CHAIR VARNISHED

designer:	Xavier Pauchard	creation:	1937
guarantee:	two years	fabrication:	handmade in Autun, France
dimensions:	W.47 [CM] D.53 [CM] H.83 [CM]	material:	steel
seat:	W.35 [CM] D.35 [CM] H.44 [CM]	finition:	varnished raw steel
weight:	5,2 [KG]	use:	indoor
highlight:	stackable up to 4 units	assembly:	assembled



T37 Chair, Galvanized

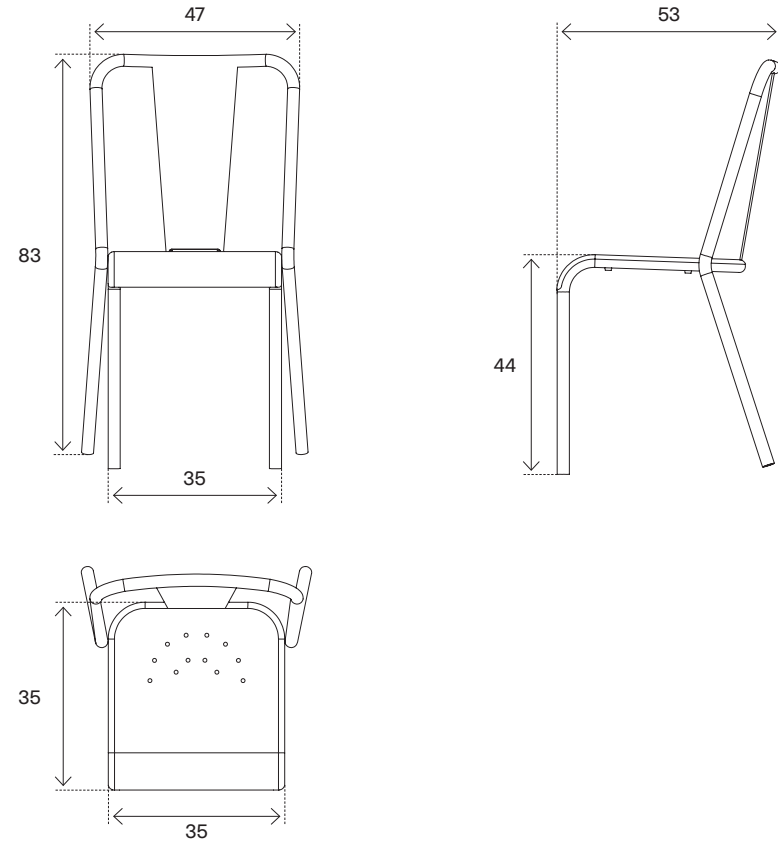

T37 CHAIR GALVANIZED

designer:	Xavier Pauchard	creation:	2024
guarantee:	two years	fabrication:	handmade in Autun, France
dimensions:	W.47 [CM] D.53 [CM] H.83 [CM]	material:	steel
seat:	W.35 [CM] D.35 [CM] H.44 [CM]	finition:	galvanized
weight:	5,2 [KG]	use:	outdoor
highlight:	stackable up to 4 units	assembly:	assembled



T37 Bench, *Pure White* color

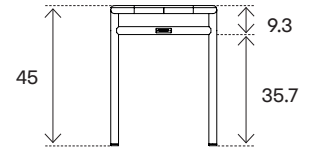
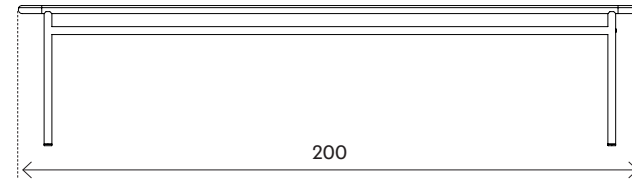

T37 BENCH

designer:	Studio Tolix	creation:	2024
guarantee:	two years	fabrication:	handmade in Autun, France
dimensions:	W.34 [CM] D.200 [CM] H.45 [CM]	material:	steel
seat:	W.34 [CM] D.200 [CM] H.45 [CM]	finition:	available page 300
weight:	15 [KG]	use:	indoor
highlight:	non-stackable	assembly:	assembled

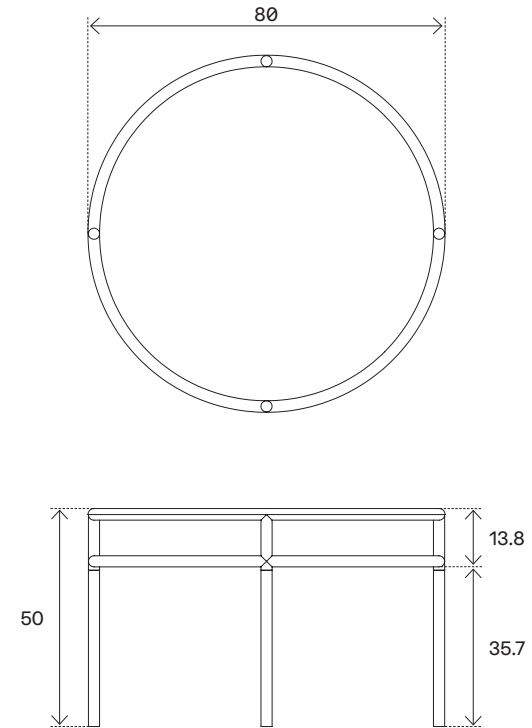
T37 Coffee Table, *Pure White color*

T37 COFFEE TABLE Ø80

designer:	Studio Tolix	creation:	2023
guarantee:	two years	fabrication:	handmade in Autun, France
dimensions:	D.80 [CM] H.50 [CM]	material:	steel
weight:	11.7 [KG]	finition:	available page 300
highlight:	non-stackable	use:	indoor
assembly:	assemble		

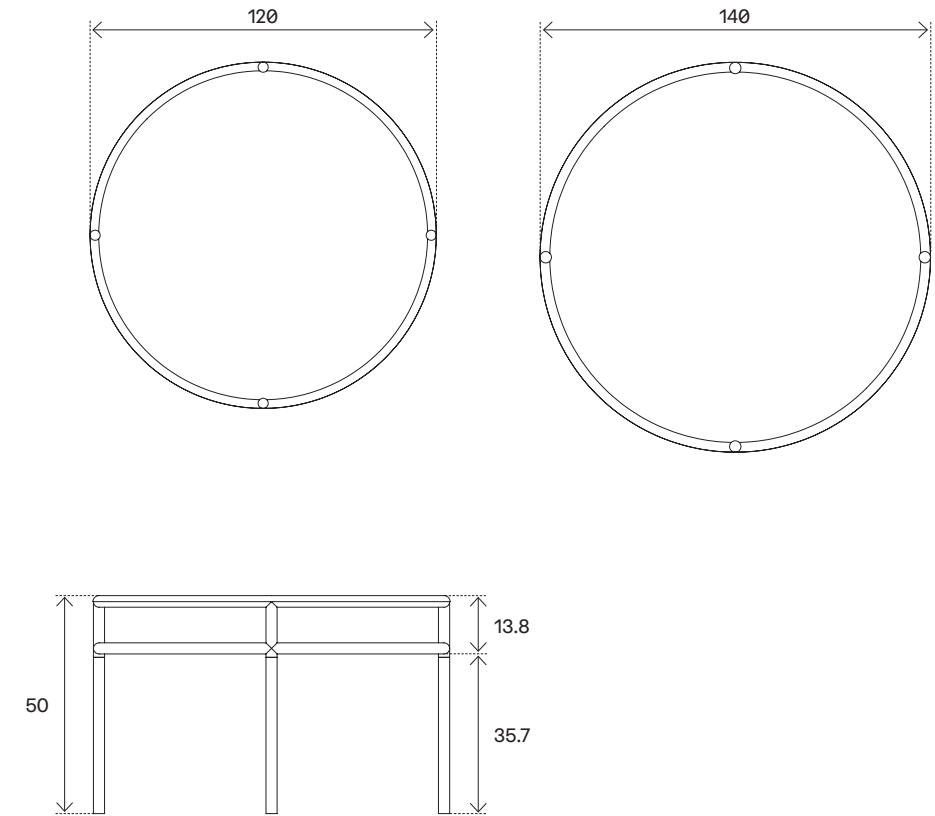

T37 Round Low Table, *Pure White* color

T37 ROUND LOW TABLE

designer:	Studio Tolix	creation:	2023
guarantee:	two years	fabrication:	handmade in Autun, France
dimensions ^[A] :	D.120 ^[CM] H.50 ^[CM]	material:	steel
dimensions ^[B] :	D.140 ^[CM] H.50 ^[CM]	finition:	available page 300
weight:	27.7 ^[KG] 33.15 ^[KG]	use:	indoor
highlight:	non-stackable	assembly:	to assemble

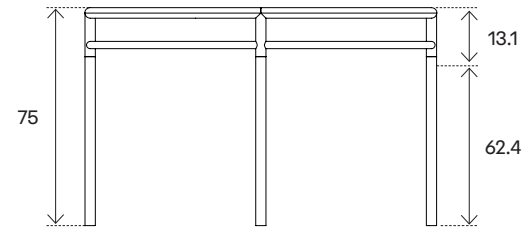
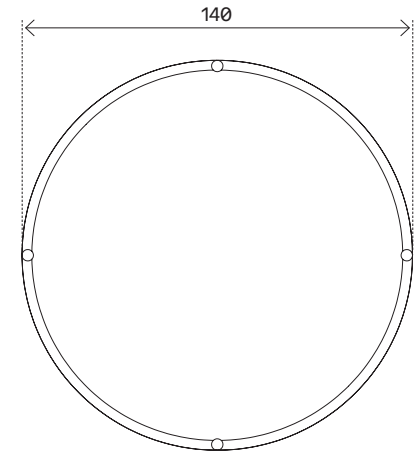
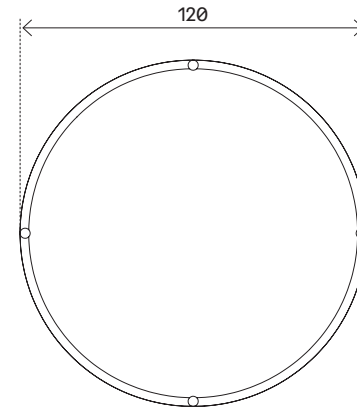

T37 Round Table, *Pure White color*

T37 ROUND TABLE

designer:	Studio Tolix	creation:	2023
guarantee:	two years	fabrication:	handmade in Autun, France
dimensions ^[A] :	D.120 ^[CM] H.75 ^[CM]	material:	steel
dimensions ^[B] :	D.140 ^[CM] H.75 ^[CM]	finition:	available page 300
weight:	32.4 ^[KG] 38.5 ^[KG]	use:	indoor
highlight:	non-stackable	assembly:	to assemble

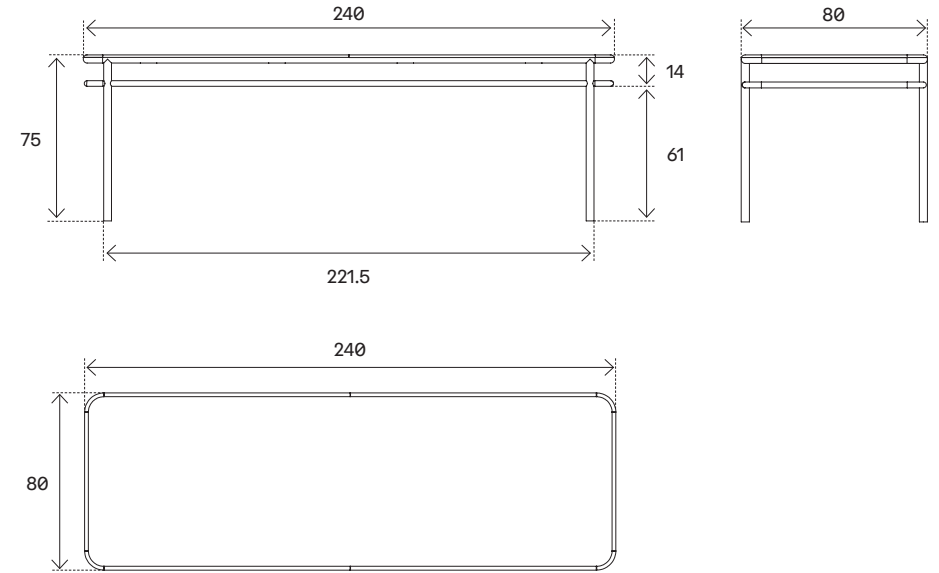
T37 Monastic Table, *Pure White color*

T37 MONASTIC TABLE

designer:	Studio Tolix	creation:	2023
guarantee:	two years	fabrication:	handmade in Autun, France
dimensions:	L.240 [CM] W.80 [CM] H.75 [CM]	material:	steel
weight:	49 [KG]	finition:	available page 300
highlight:	non-stackable	use:	indoor
assembly:	to assemble		

T37 WOVEN COLLECTION [ed. 2024]

Au cœur de l'histoire de la chaise T37 qui fut créée pour la 24^{ème} Exposition Universelle de Paris de 1937, restaient dissimulés quelques trésors récemment exhumés.

C'est le cas de la chaise T37 à l'assise tressée créée en 1948 par Xavier Pauchard et rééditée en mars 2024 par Tolix dans le cadre de la toute première édition du salon Matter and Shape qui s'est tenu dans les Jardins des Tuileries à Paris.

Autour de ce motif singulier et géométrique, le studio Tolix a entamé la création d'une ligne de mobilier versatile. Un premier tabouret à l'assise carrée a été dessiné en différentes tailles lui permettant tant à la fois d'être une assise élégante qu'une table d'appoint aux fonctions multiples. Viennent compléter cette collection une table carrée et une table basse ronde.

La pureté des lignes géométriques et la finesse du tressage leur confèrent une légèreté visuelle et un graphisme très Art Nouveau.

La désormais reconnaissable palette de couleurs propre à la Manufacture Tolix, est dédiée à ces accessoires permettant une grande versatilité dans l'usage de ces objets dans les jardins et intérieurs modernes.^[FR]

At the heart of the history of the T37 chair, which was created for the 24th Universal Exposition in Paris in 1937, a few treasures remained hidden until recently unearthed.

This is the case with the T37 chair with a woven seat, created in 1948 by Xavier Pauchard and reissued in March 2024 by Tolix as part of the first edition of the Matter and Shape fair held in the Tuileries Gardens in Paris.

Centered around this unique and geometric pattern, Tolix Studio has embarked on the creation of a versatile furniture line. A first stool with a square seat was designed in various sizes, allowing it to be both an elegant seat and a multi-functional side table. A square table and a round coffee table complete this collection. The purity of the geometric lines and the delicacy of the weaving give them a visual lightness and a very Art Nouveau graphic design. The now recognizable palette of colors characteristic of Tolix's Manufacture is dedicated to these accessories, allowing for great versatility in the use of these objects in modern gardens and interiors.^[EN]



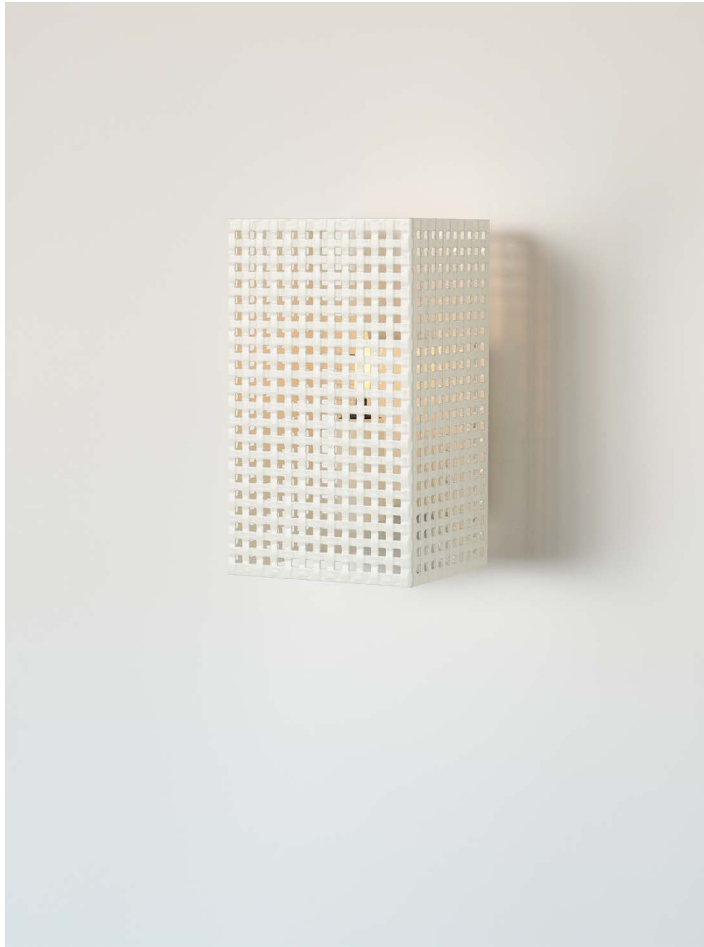

T37 Woven Wall Lamp, *Pure White color*

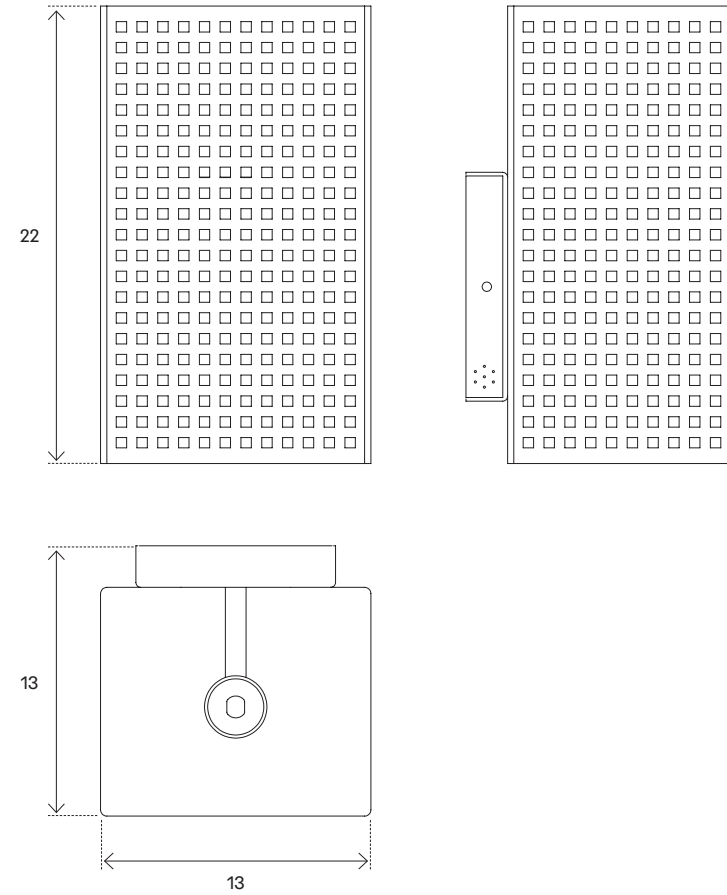
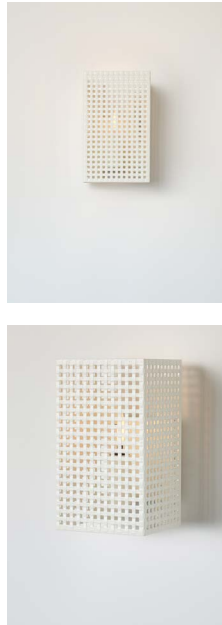

T37 WOVEN WALL LAMP INDOOR

designer:	Studio Tolix	creation:	2024
guarantee:	two years	fabrication:	handmade in Autun, France
dimensions:	W.13 ^[CM] D.13 ^[CM] H.22 ^[CM]	material:	stainless steel steel
weight:	0.78 ^[KG]	finition:	available page 300
highlights:	non stackable	use:	indoor
source:	E14	assembly:	assembled



T37 Square Woven Candle Jar Holder M, Pure White color

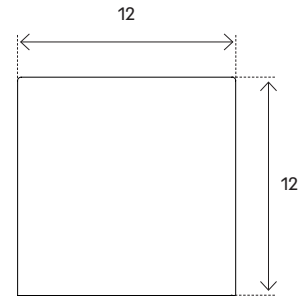
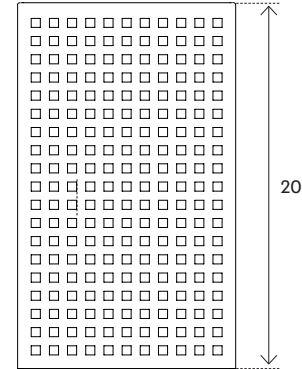

T37 SQUARE WOVEN CANDLE JAR HOLDER M

designer:	Studio Tolix	creation:	2024
guarantee:	two years	fabrication:	handmade in Autun, France
dimensions:	W.12 ^[CM] D.12 ^[CM] H.20 ^[CM]	material:	steel
weight:	0.71 ^[KG]	finition:	available page 300
highlights:	non stackable	use:	indoor outdoor
assembly:	assembled		



T37 Square Woven Candle Jar Holder L, *Pure White color*

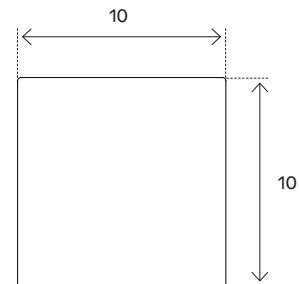
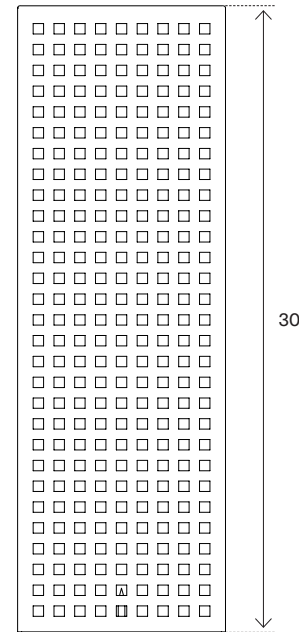
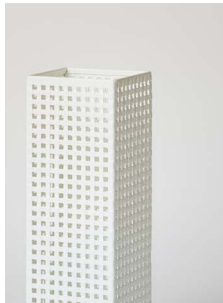

T37 SQUARE WOVEN CANDLE JAR HOLDER L

designer:	Studio Tolix	creation:	2024
guarantee:	two years	fabrication:	handmade in Autun, France
dimensions:	W.10 ^[CM] D.10 ^[CM] H.30 ^[CM]	material:	steel
weight:	0.82 ^[KG]	finition:	available page 300
highlights:	non stackable	use:	indoor outdoor
assembly:	assembled		

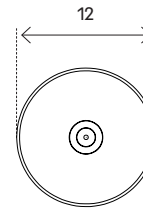
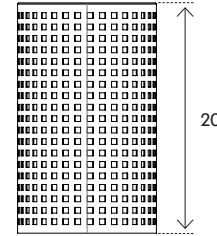

T37 Round Woven Candle Jar Holder M, *Pure White color*

T37 ROUND WOVEN CANDLE JAR HOLDER M

designer:	Studio Tolix	creation:	2024
guarantee:	two years	fabrication:	handmade in Autun, France
dimensions:	D.12 ^[CM] H.20 ^[CM]	material:	steel
weight:	0.54 ^[KG]	finition:	available page 300
highlights:	non stackable	use:	indoor outdoor
assembly:	assembled		



T37 Round Woven Candle Jar Holder L, Pure White color

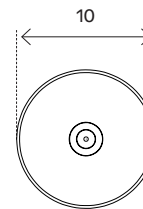
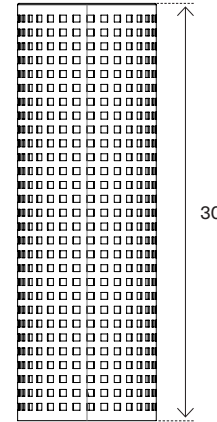

T37 ROUND WOVEN CANDLE JAR HOLDER L

designer:	Studio Tolix	creation:	2024
guarantee:	two years	fabrication:	handmade in Autun, France
dimensions:	D.10 ^[CM] H.30 ^[CM]	material:	steel
weight:	0.60 ^[KG]	finition:	available page 300
highlights:	non stackable	use:	indoor outdoor
assembly:	assembled		



T37 Woven Chair, Pure White color

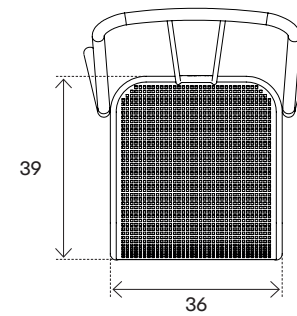
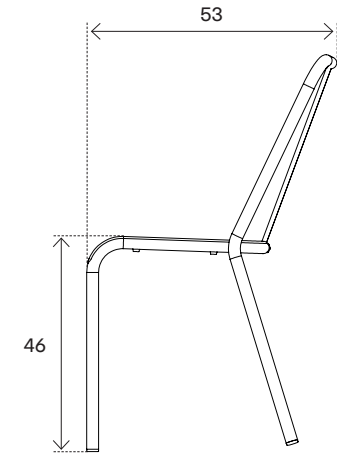
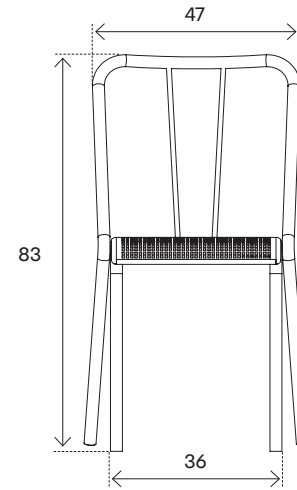

T37 WOVEN CHAIR

designer:	Xavier Pauchard	creation:	1948
guarantee:	two years	fabrication:	handmade in Autun, France
dimensions:	W.47 [CM] D.53 [CM] H.83 [CM]	material:	stainless steel
seat:	W.36 [CM] D.39 [CM] H.46 [CM]	finition:	available page 300
weight:	4.2 [KG]	use:	indoor outdoor
highlight:	non stackable	assembly:	assembled



T37 Woven Square Stool, *Pure White color*

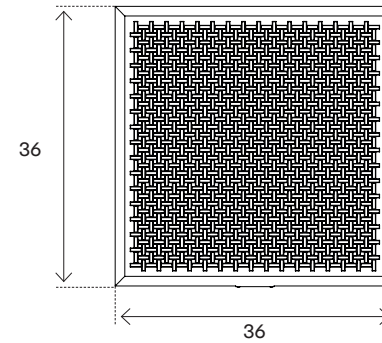
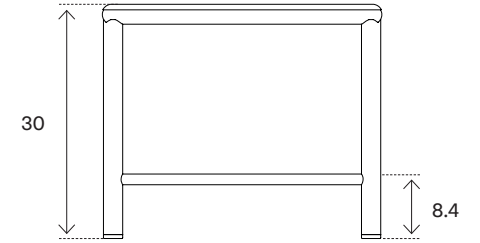
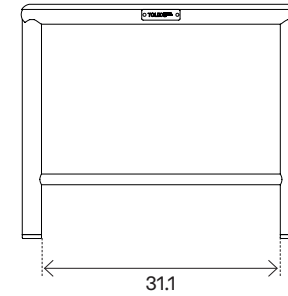

T37 WOVEN SQUARE STOOL H30

designer:	Studio Tolix	creation:	2024
guarantee:	two years	fabrication:	handmade in Autun, France
dimensions:	W.36 [CM] D.36 [CM] H.30 [CM]	material:	stainless steel
seat:	W.36 [CM] D.36 [CM] H.30 [CM]	finition:	available page 300
weight:	4.18 [KG]	use:	indoor outdoor
highlight:	non stackable	assembly:	assembled



T37 Woven Pedestal, *Pure White color*

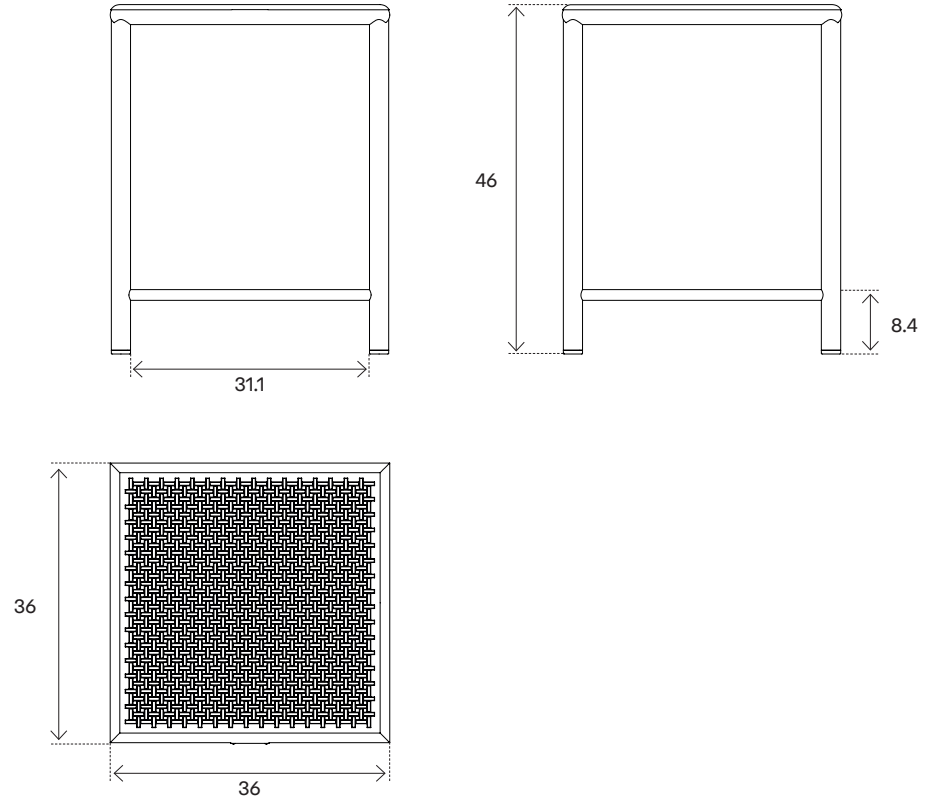

T37 WOVEN SQUARE STOOL H46

designer:	Studio Tolix	creation:	2024
guarantee:	two years	fabrication:	handmade in Autun, France
dimensions:	W.36 [CM] D.36 [CM] H.46 [CM]	material:	stainless steel
weight:	4.7 [KG]	finition:	available page 300
highlight:	non-stackable	use:	indoor outdoor
assembly:	assembled		



T37 Woven Pedestal, *Pure White color*

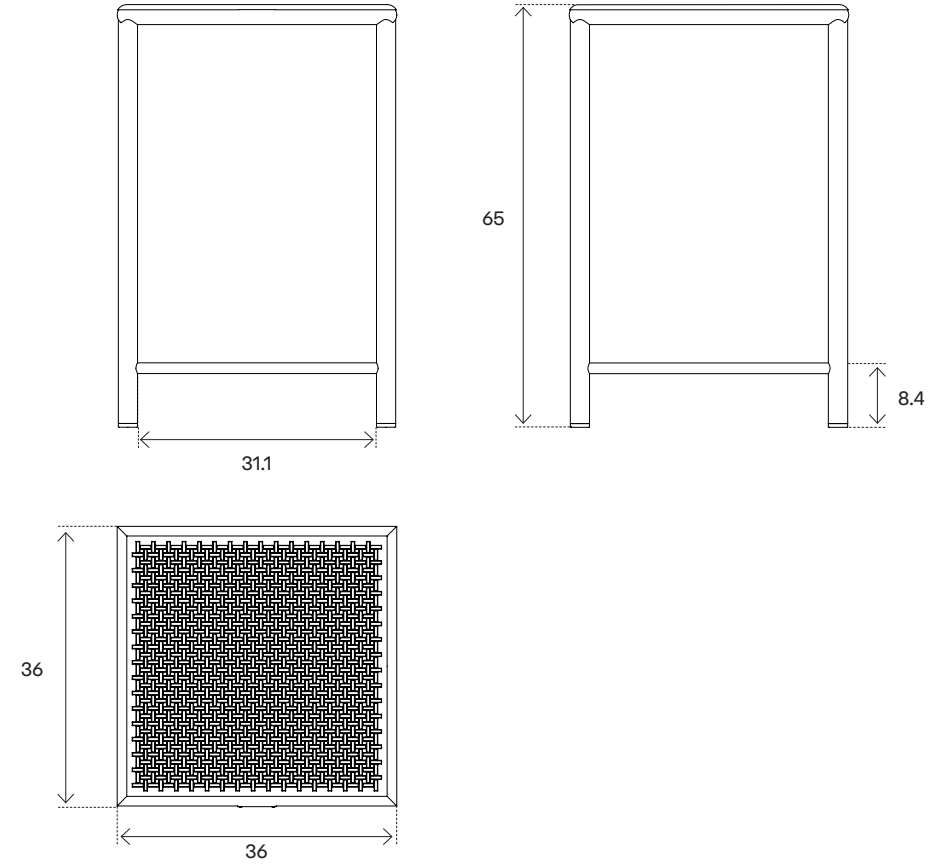

T37 WOVEN SQUARE STOOL H65

designer:	Studio Tolix	creation:	2024
guarantee:	two years	fabrication:	handmade in Autun, France
dimensions:	W.36 [CM] D.36 [CM] H.65 [CM]	material:	stainless steel
weight:	5.7 [KG]	finition:	available page 300
highlight:	non-stackable	use:	indoor outdoor
assembly:	assembled		

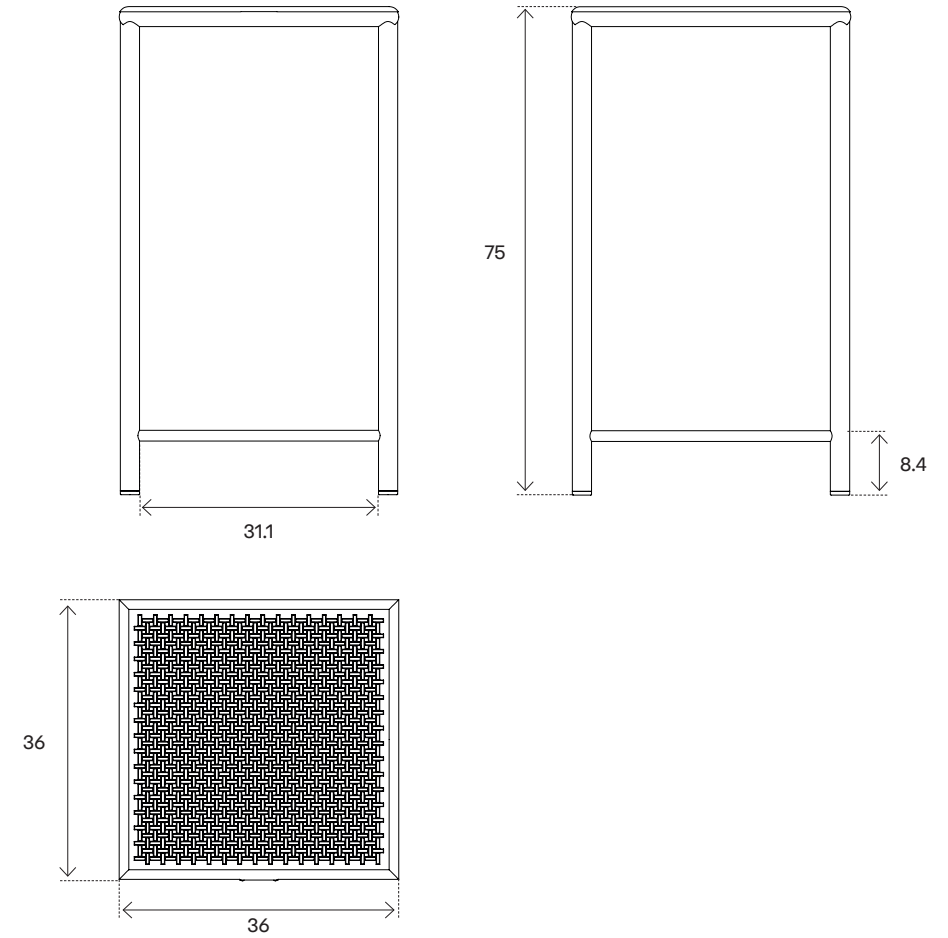
T37 Woven Pedestal, *Pure White color*

T37 WOVEN SQUARE STOOL H75

designer:	Studio Tolix	creation:	2024
guarantee:	two years	fabrication:	handmade in Autun, France
dimensions:	W.36 ^[CM] D.36 ^[CM] H.75 ^[CM]	material:	stainless steel
weight:	6.2 ^[KG]	finition:	available page 300
highlight:	non-stackable	use:	indoor outdoor
assembly:	assembled		



T37 Woven Square Table, *Pure White color*

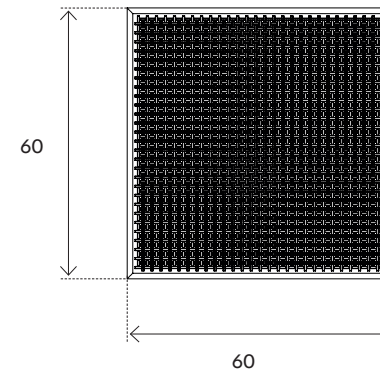
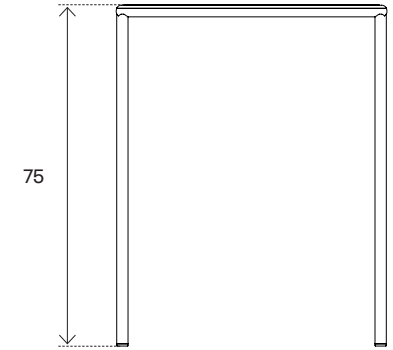
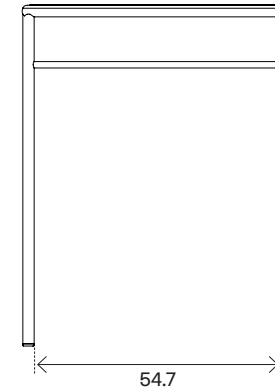

T37 WOVEN SQUARE TABLE

designer:	Studio Tolix	creation:	2024
guarantee:	two years	fabrication:	handmade in Autun, France
dimensions:	W.60 [CM] D.60 [CM] H.75 [CM]	material:	stainless steel
weight:	9.27 [KG]	finition:	available page 300
highlight:	non-stackable	use:	indoor outdoor
assembly:	assembled		



T37 Woven Round Coffee Table, *Pure White* color

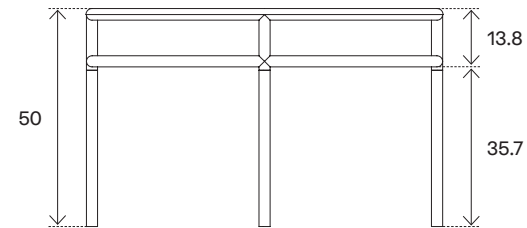
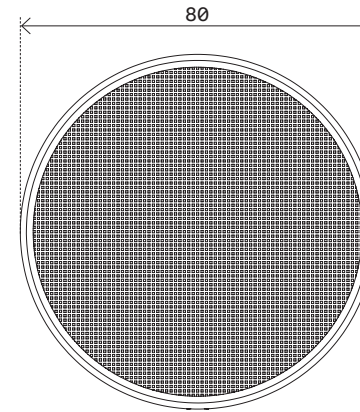

T37 WOVEN ROUND COFFEE TABLE

designer:	Studio Tolix	creation:	2024
guarantee:	two years	fabrication:	handmade in Autun, France
dimensions:	D.80 [CM] H.50 [CM]	material:	stainless steel
weight:	9.3 [KG]	finition:	available page 300
highlight:	non-stackable	use:	indoor outdoor
assembly:	assembled		

UD. COLLECTION

[ed. 2024]

Les premières chaises UD voient le jour en 1958, à l'initiative de Jean Pauchard pour une commande de l'Université de Dijon. Elles sont marquées par une structure tubulaire, un dossier ajouré en trois tubes fins et cintrés, et une assise en Formica rembourrée de similicuir. D'autres versions suivront, comme la chaise UD2 en 1963 avec une assise en bois de hêtre.

La chaise UD, caractérisée par ses lignes légères et féminines, est revisitée par le Studio Tolix et se voit adjoindre une table dont la finesse des courbes se marie parfaitement à un plateau acier semblant flotter en suspension. Une version à plateau chêne teinté réalisé par un ébéniste du Morvan lui confère un caractère encore plus affirmé.

La collection UD se distingue par sa peinture brun noir profond ou sa robe blanc brillant. Elle s'intègre ainsi parfaitement dans des intérieurs exigeants, offrant des options tout acier ou bois pour répondre aux préférences d'épuration ou de chaleur. À l'avenir, de nouvelles matières viendront enrichir son assise, renforçant ainsi son pouvoir de séduction.^[FR]

The first UD chairs were born in 1958, at the initiative of Jean Pauchard for an order from the University of Dijon. They are characterized by a tubular structure, a perforated backrest with three slender and curved tubes, and a seat padded with Formica and faux leather. Other versions will follow, such as the UD2 chair in 1963 with a beechwood seat.

The UD chair, characterized by its light and feminine lines, is revisited by Studio Tolix and is accompanied by a table whose delicate curves perfectly complement a steel top that seems to float in suspension. A version with a stained oak top crafted by a Morvan cabinetmaker gives it an even more pronounced character.

The UD collection stands out with its deep black-brown paint or its glossy white finish. It integrates perfectly into demanding interiors, offering all-steel or all-wood options to meet preferences for minimalism or warmth. In the future, new material will enrich its seating, thereby enhancing its seductive power.^[EN]





UD Chair, *Pure White color*

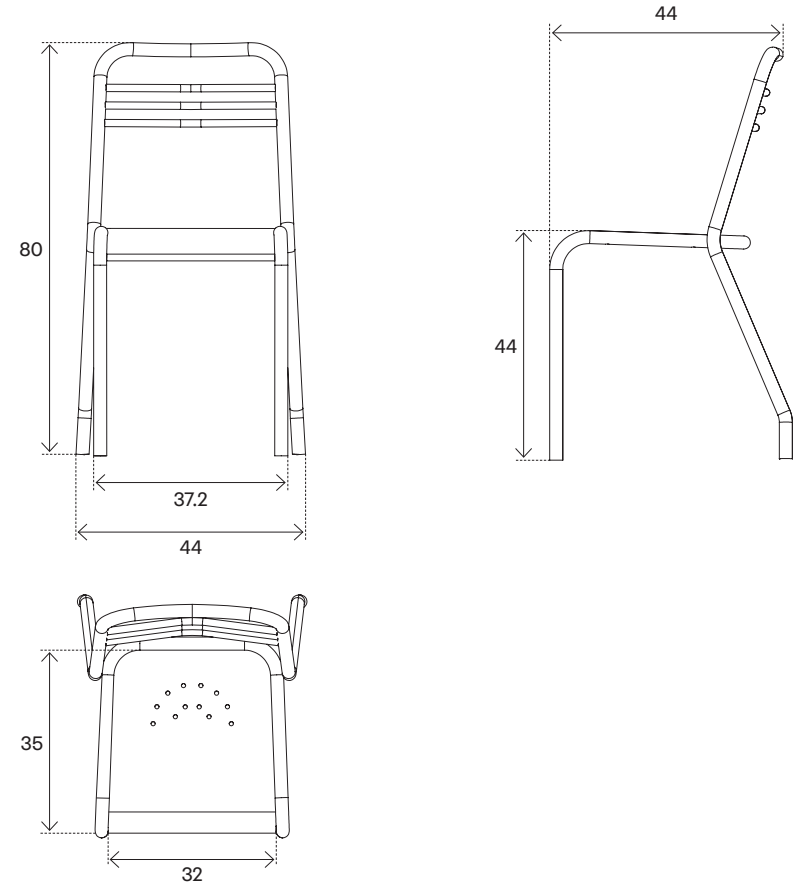

UD CHAIR

designer:	Jean Pauchard	creation:	1958
guarantee:	two years	fabrication:	handmade in Autun, France
dimensions:	W.47 [CM] D.44 [CM] H.80 [CM]	material:	steel
seat:	W.32 [CM] D.35 [CM] H.44 [CM]	finition:	available page 300
weight:	4.7 [KG]	use:	indoor
highlight:	non-stackable	assembly:	assembled



UD Chair, Raw Steel Varnished

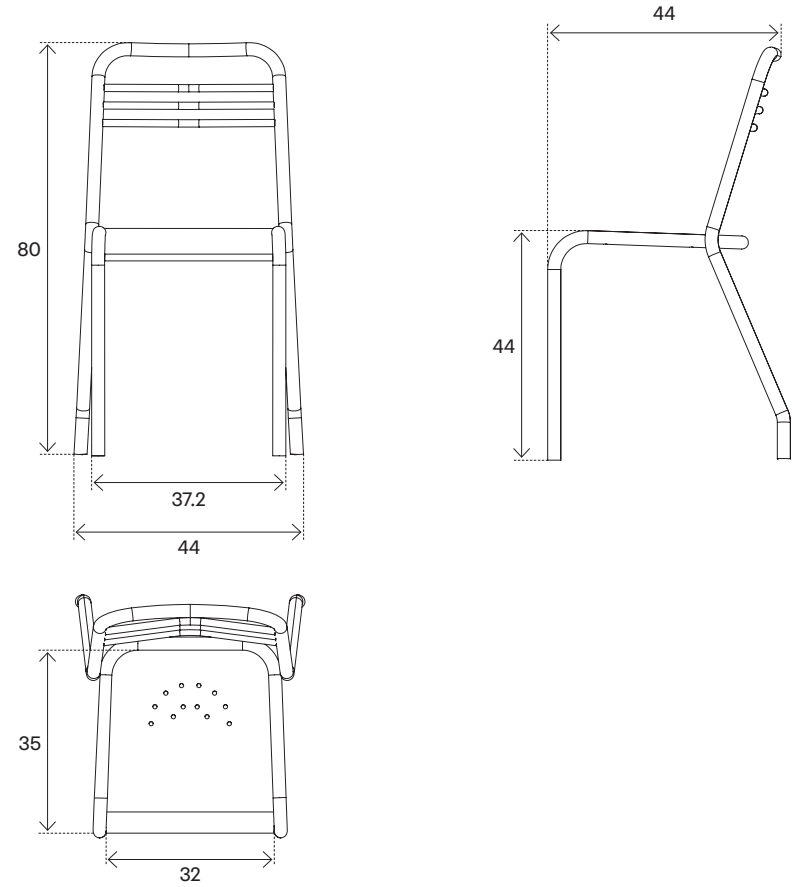

UD CHAIR VARNISHED

designer:	Jean Pauchard	creation:	1958
guarantee:	two years	fabrication:	handmade in Autun, France
dimensions:	W.47 [CM] D.44 [CM] H.80 [CM]	material:	steel
seat:	W.32 [CM] D.35 [CM] H.44 [CM]	finition:	varnished raw steel
weight:	5,0 [KG]	use:	indoor
highlight:	non-stackable	assembly:	assembled

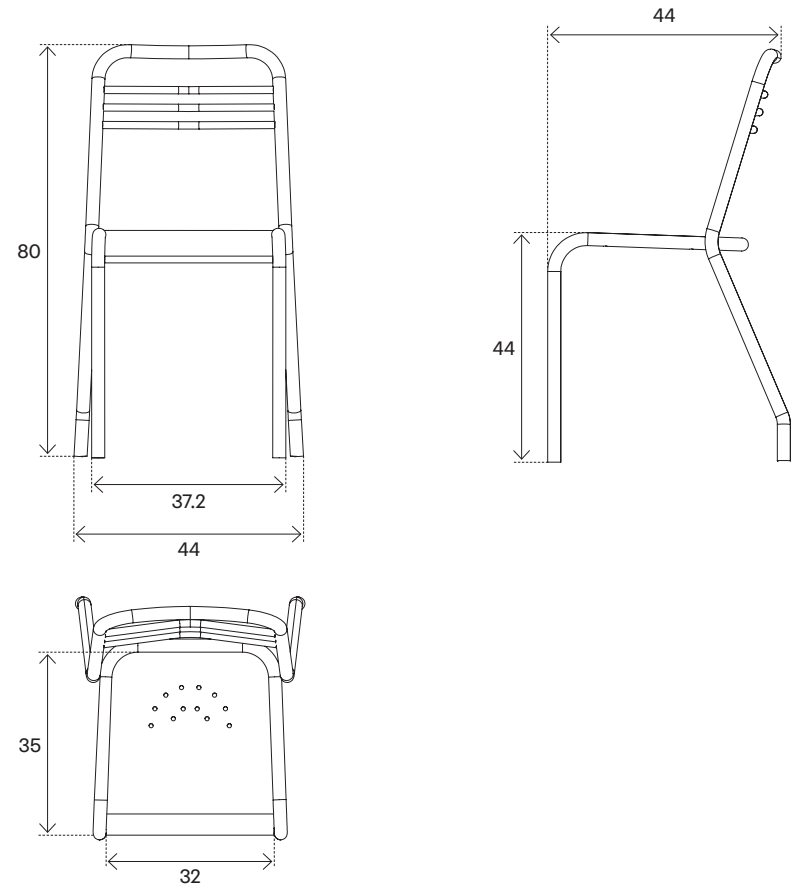

UD Chair, Galvanized

UD CHAIR GALVANIZED

designer:	Jean Pauchard	creation:	1958
guarantee:	two years	fabrication:	handmade in Autun, France
dimensions:	W.47 ^[CM] D.44 ^[CM] H.80 ^[CM]	material:	steel
seat:	W.32 ^[CM] D.35 ^[CM] H.44 ^[CM]	finition:	galvanized
weight:	5,0 ^[KG]	use:	outdoor
highlight:	non-stackable	assembly:	assembled

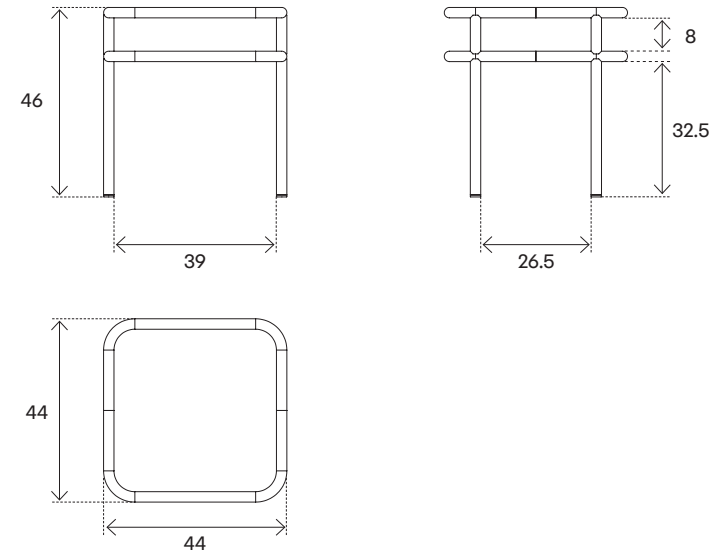
UD Side Square Table Light Oak Table Top, *Brown Black color*

UD SIDE SQUARE TABLE LIGHT OAK TABLE TOP

designer:	Studio Tolix	creation:	2024
guarantee:	two years	fabrication:	handmade in Autun, France
dimensions:	W.44 [CM] D.44 [CM] H.46 [CM]	material:	steel light oak
weight:	5.77 [KG]	finition:	available page 300
highlight:	non-stackable	use:	indoor
assembly:	to assemble		

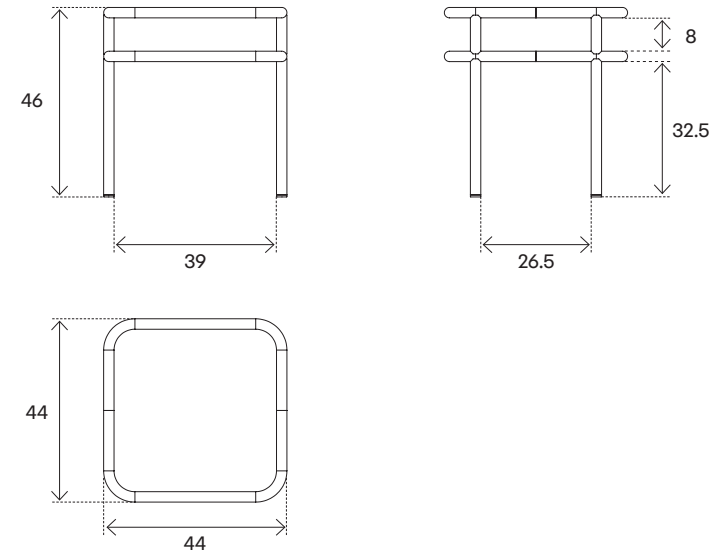
UD Side Square Table Dark Oak Table Top, *Brown Black color*

UD SIDE SQUARE TABLE DARK OAK TABLE TOP

designer:	Studio Tolix	creation:	2024
guarantee:	two years	fabrication:	handmade in Autun, France
dimensions:	W.44 [CM] D.44 [CM] H.46 [CM]	material:	steel dark oak
weight:	5.77 [KG]	finition:	available page 300
highlight:	non-stackable	use:	indoor
assembly:	to assemble		

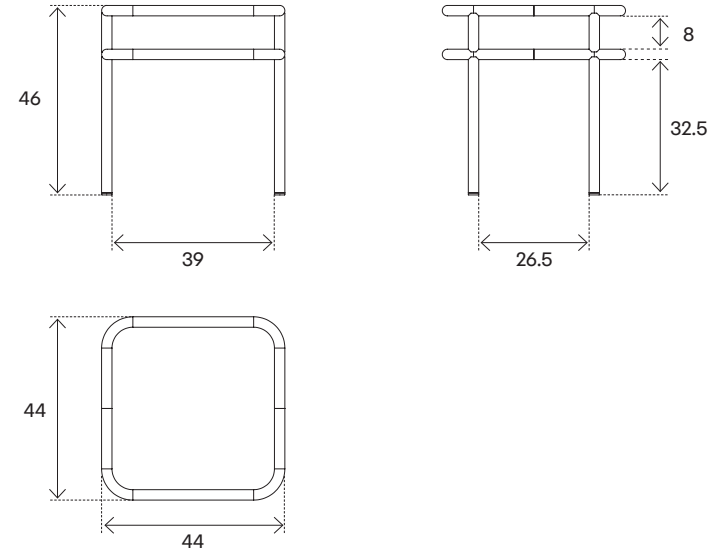
UD Side Square Table Stained Oak Table Top, *Brown Black color*

UD SIDE SQUARE TABLE STAINED OAK TABLE TOP

designer:	Studio Tolix	creation:	2024
guarantee:	two years	fabrication:	handmade in Autun, France
dimensions:	W.44 [CM] D.44 [CM] H.46 [CM]	material:	steel stained oak
weight:	5.77 [KG]	finition:	available page 300
highlight:	non-stackable	use:	indoor
assembly:	to assemble		

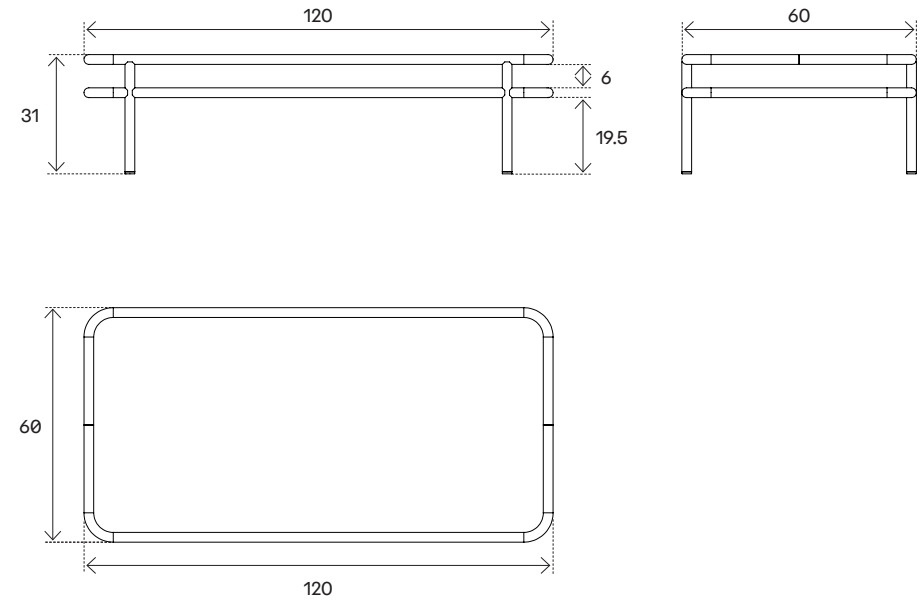
UD Rectangular Coffee Table Light Oak Table Top, *Brown Black color*

UD RECTANGULAR COFFEE TABLE LIGHT OAK TABLE TOP

designer:	Studio Tolix	creation:	2024
guarantee:	two years	fabrication:	handmade in Autun, France
dimensions:	W.120 [CM] D.60 [CM] H.31 [CM]	material:	steel light oak
weight:	13.6 [KG]	finition:	available page 300
highlight:	non-stackable	use:	indoor
assembly:	assemble		



UD Rectangular Coffee Table Dark Oak Table Top, *Brown Black color*

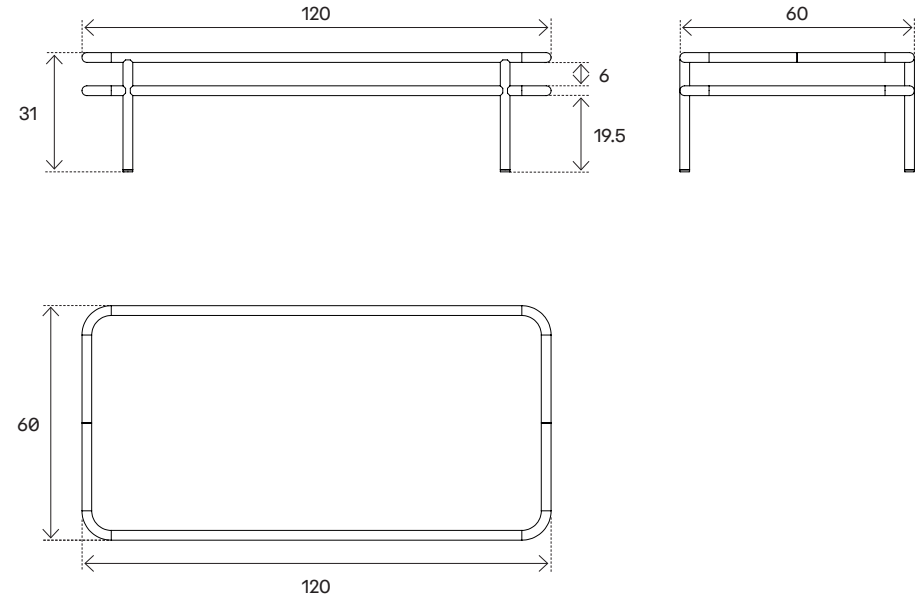

UD RECTANGULAR COFFEE TABLE DARK OAK TABLE TOP

designer:	Studio Tolix	creation:	2024
guarantee:	two years	fabrication:	handmade in Autun, France
dimensions:	W.120 [CM] D.60 [CM] H.31 [CM]	material:	steel dark oak
weight:	13.6 [KG]	finition:	available page 300
highlight:	non-stackable	use:	indoor
assembly:	assemble		

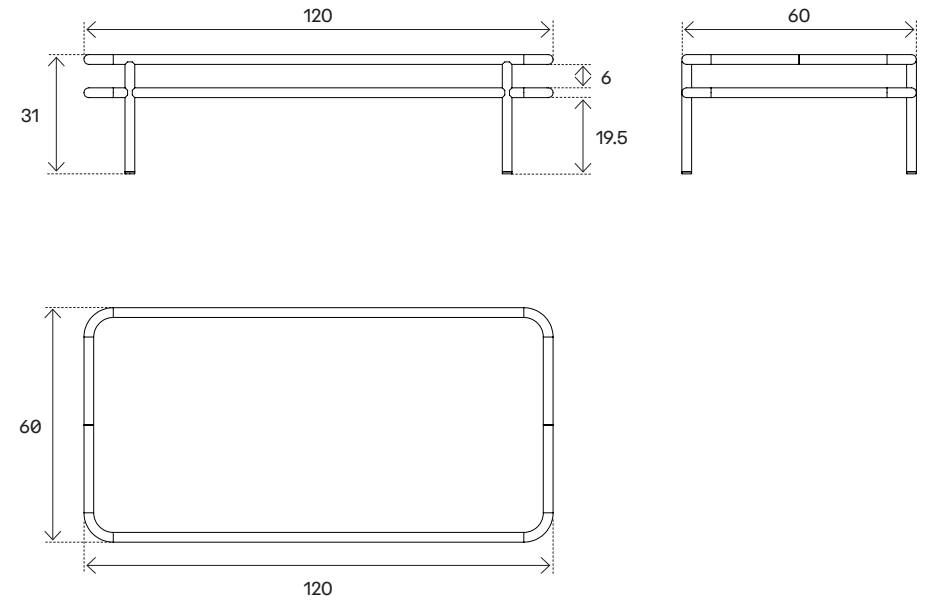
UD Rectangular Coffee Table Stained Oak Table Top, *BrownBlack* color

UD RECTANGULAR COFFEE TABLE STAINED OAK TABLE TOP

designer:	Studio Tolix	creation:	2024
guarantee:	two years	fabrication:	handmade in Autun, France
dimensions:	W.120 [CM] D.60 [CM] H.31 [CM]	material:	steel stained oak
weight:	13.6 [KG]	finition:	available page 300
highlight:	non-stackable	use:	indoor
assembly:	assemble		

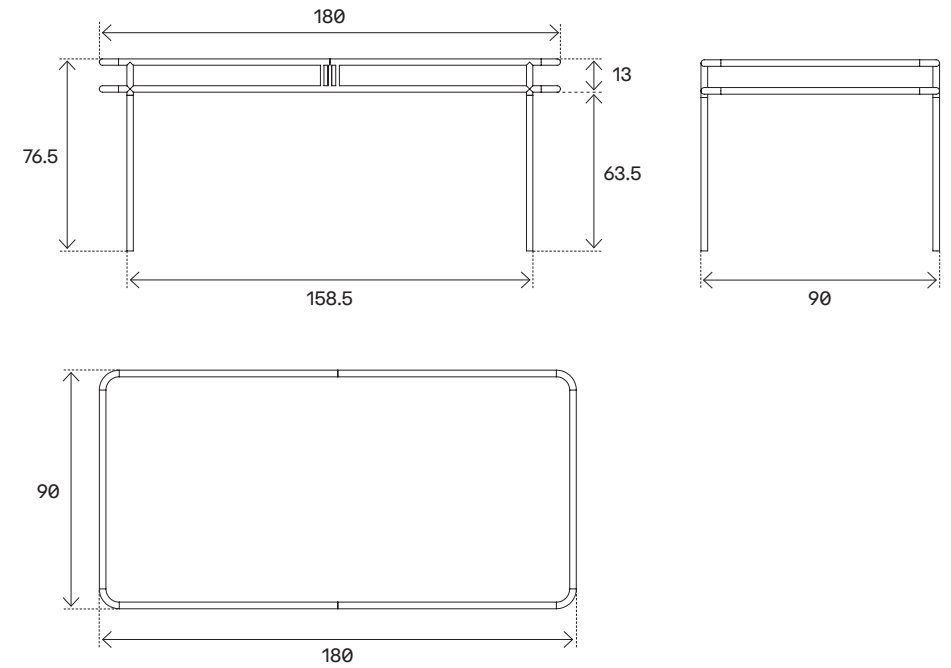
UD Table, *Pure White color*

UD TABLE

designer:	Studio Tolix	creation:	2023
guarantee:	two years	fabrication:	handmade in Autun, France
dimensions:	L.180 [CM] W.90 [CM] H.76.5 [CM]	material:	steel
weight:	30.5 [KG]	finition:	available page 300
highlight:	non-stackable	use:	indoor
assembly:	to assemble		

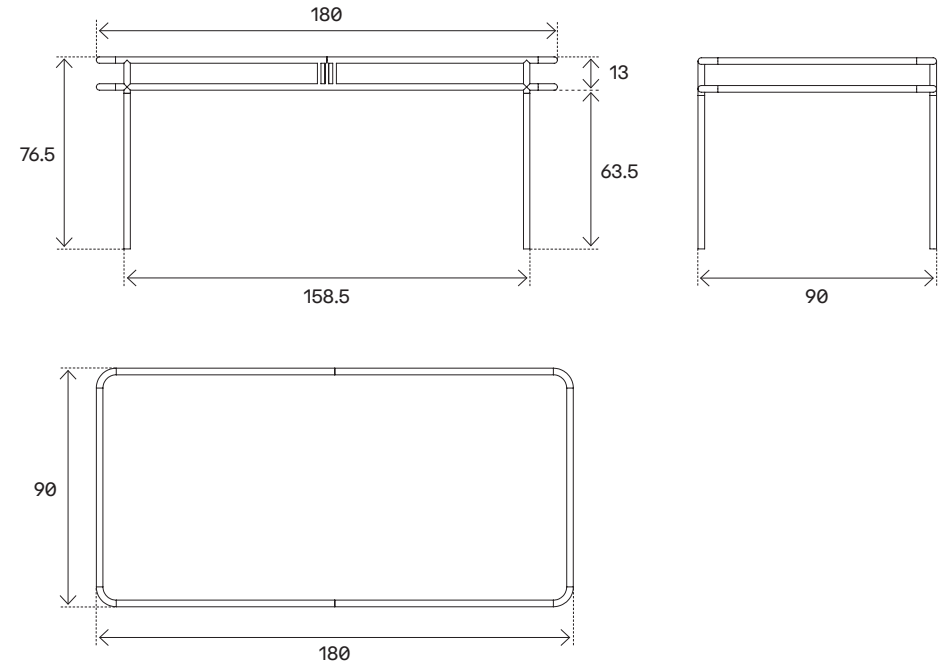

UD Table Light Oak Table Top, *Pure White color*

UD TABLE LIGHT OAK TABLE TOP

designer:	Studio Tolix	creation:	2023
guarantee:	two years	fabrication:	handmade in Autun, France
dimensions:	L.180 [CM] W.90 [CM] H.76.5 [CM]	materials:	steel light oak
weight:	28.0 [KG]	finition:	available page 300
highlight:	non-stackable	use:	indoor
assembly:	to assemble		

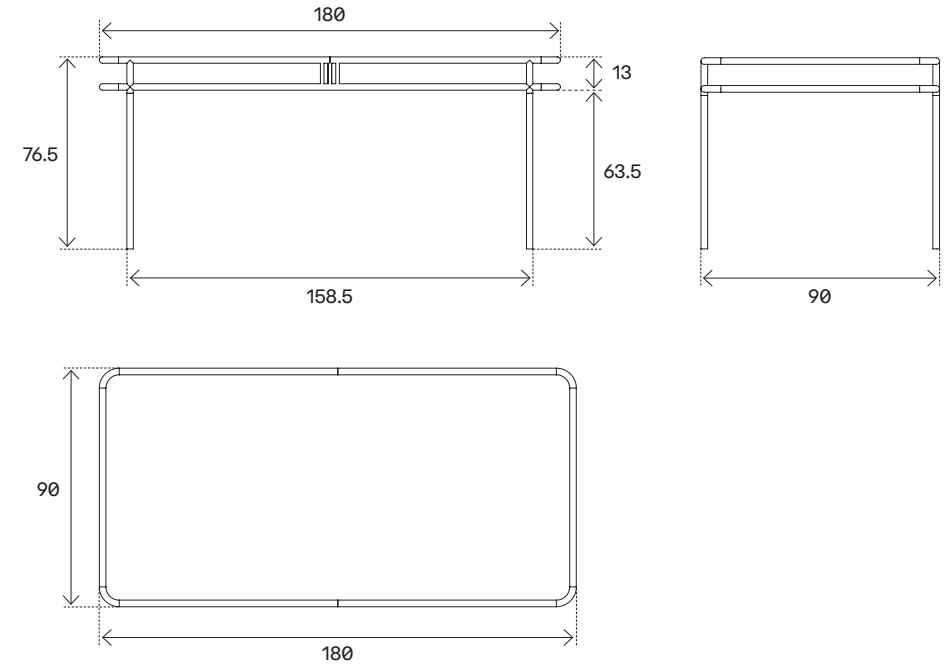
UD Table Dark Oak Table Top, *Brown Black color*

UD TABLE DARK OAK TABLE TOP

designer:	Studio Tolix	creation:	2023
guarantee:	two years	fabrication:	handmade in Autun, France
dimensions:	L.180 [CM] W.90 [CM] H.76.5 [CM]	materials:	steel dark oak
weight:	28.0 [KG]	finition:	available page 300
highlight:	non-stackable	use:	indoor
assembly:	to assemble		

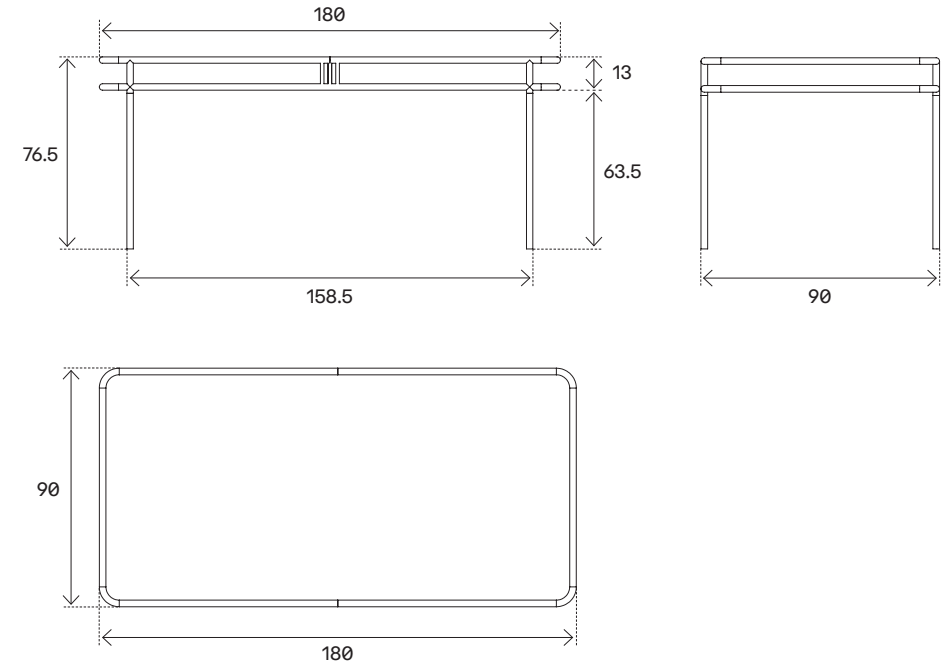
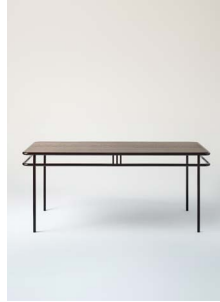
UD Table Stained Oak Table Top, *Brown Black color*

UD TABLE STAINED OAK TABLE TOP

designer:	Studio Tolix	creation:	2023
guarantee:	two years	fabrication:	handmade in Autun, France
dimensions:	L.180 [CM] W.90 [CM] H.76.5 [CM]	materials:	steel stained oak
weight:	28.0 [KG]	finition:	available page 300
highlight:	non-stackable	use:	indoor
assembly:	to assemble		



UD Table Light Oak Table Top, Raw Steel Varnished

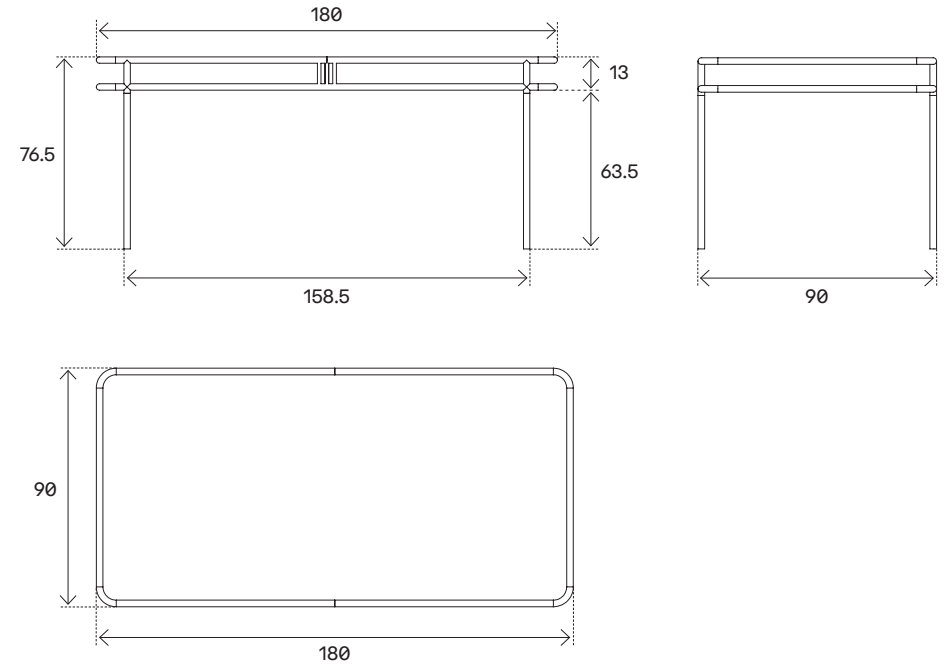

UD TABLE VARNISHED LIGHT OAK TABLE TOP

designer:	Studio Tolix	creation:	2023
guarantee:	two years	fabrication:	handmade in Autun, France
dimensions:	L.180 [CM] W.90 [CM] H.76.5 [CM]	materials:	steel light oak
weight:	28.0 [KG]	finition:	varnished raw steel
highlight:	non-stackable	use:	indoor
assembly:	to assemble		



UD Table Stained Oak Table Top, Raw Steel Varnished

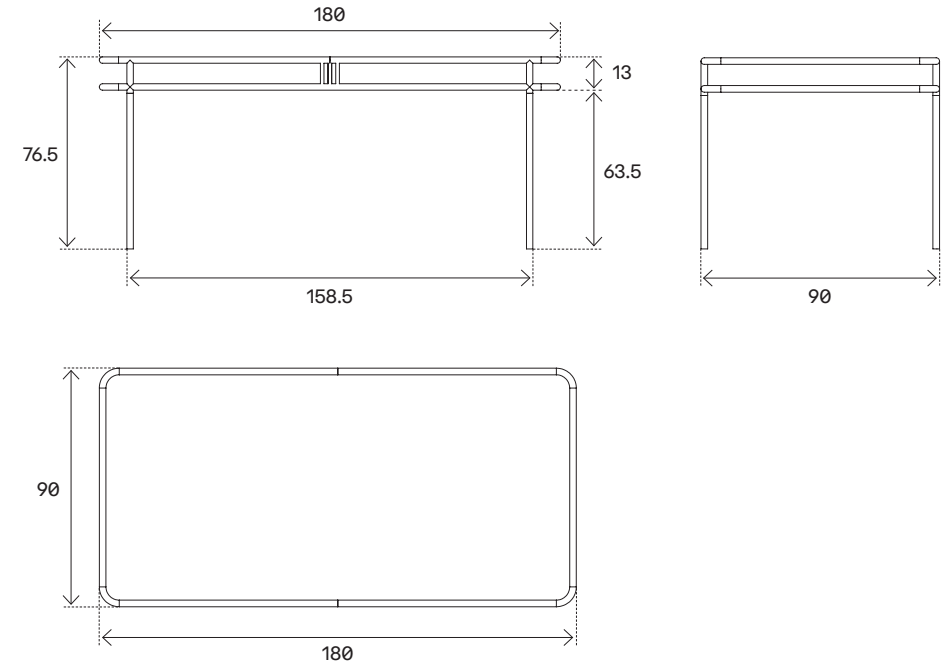

UD TABLE VARNISHED STAINED OAK TABLE TOP

designer:	Studio Tolix	creation:	2023
guarantee:	two years	fabrication:	handmade in Autun, France
dimensions:	L.180 [CM] W.90 [CM] H.76.5 [CM]	materials:	steel stained oak
weight:	28.0 [KG]	finition:	varnished raw steel
highlight:	non-stackable	use:	indoor
assembly:	to assemble		

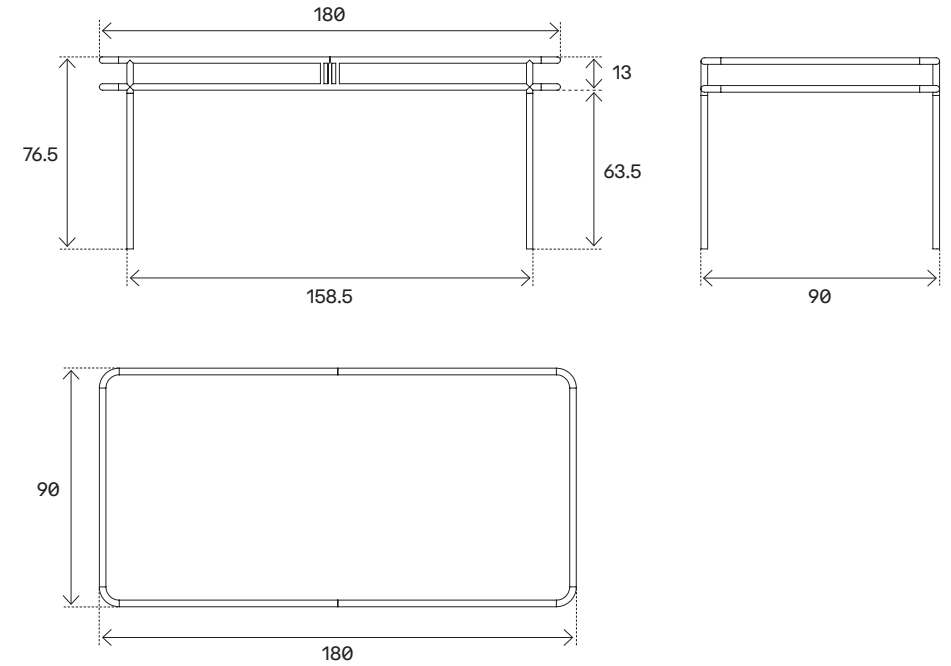
UD Table Dark Oak Top, *Raw Steel Varnished*

UD TABLE VARNISHED DARK OAK TABLE TOP

designer:	Studio Tolix	creation:	2023
guarantee:	two years	fabrication:	handmade in Autun, France
dimensions:	L.180 [CM] W.90 [CM] H.76.5 [CM]	materials:	steel dark oak
weight:	28.0 [KG]	finition:	varnished raw steel
highlight:	non-stackable	use:	indoor
assembly:	to assemble		

P.COLLECTION

[ed. 2024]

La collection P pour Patio est née sous le trait de crayon de la designer Pauline Deltour. Première femme à imaginer une collection pour Tolix, Pauline Deltour a réussi, avec PATIO, à s'imprégner de l'ADN de Tolix en apportant son élégance et sa légèreté toute féminine.

La facette artistique, qui lui est chère, rejoint celle plus pratique, résolument tournée vers l'utilisateur. Patio est un ensemble outdoor alors composé de fauteuils, fauteuils lounge et tables déclinés en plusieurs versions.

La collection était restée orpheline et inachevée, mais c'était sans compter l'énergie de ses proches et de son équipe qui a pris soin de la terminer dès 2024. Aussi, de nouveaux modèles voient le jour, agrémentant cette collection intemporelle.

Légère et élégante, la collection Patio permet aujourd'hui de répondre aux attentes des particuliers exigeants et esthètes souhaitant mettre en valeur leur extérieur ou à celles des professionnels à la recherche d'une offre unique pour garantir l'hospitalité de leurs invités.^[FR]

The P for Patio collection was born from the pencil of designer Pauline Deltour. The first woman to envision a collection for Tolix, Pauline Deltour succeeded in achieving, with PATIO in 2019, the alchemy of poetry and robustness.

The artistic facet, dear to her, converges with the more practical one, decidedly focused on the user. The pursuit of the precise and accurate line, choices of colors and materials contribute to the identity of her work and the realization of this collection. Patio is an outdoor ensemble consisting of chairs, lounge chairs, and tables in various versions.

The collection remained orphaned and unfinished, but that was without counting on the energy of her loved ones and her team, who took care to complete it by 2024. Additionally, new models are emerging, enhancing this timeless collection.

Light and elegant, the Patio collection now meets the expectations of discerning individuals and aesthetes wishing to enhance their outdoor spaces, as well as those of professionals seeking a unique offering to ensure the hospitality of their guests.^[EN]





Patio Slatted Chair, *Pure White* color

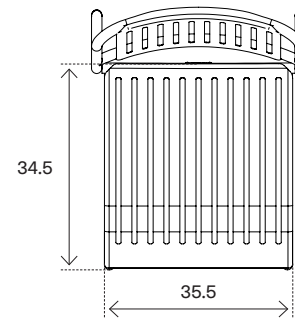
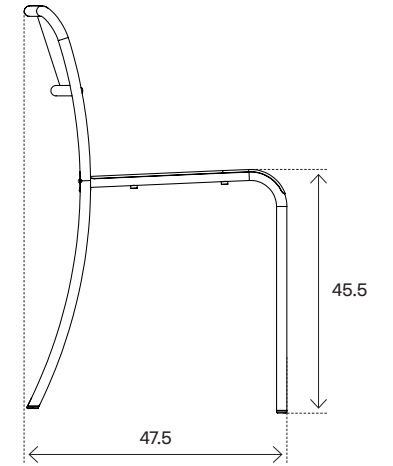
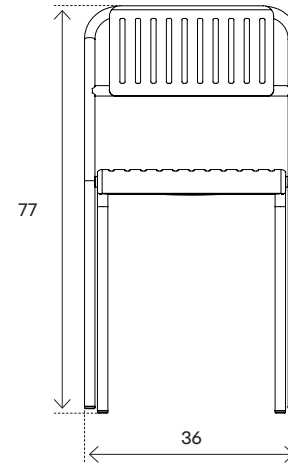

PATIO SLATTED CHAIR

designer:	Pauline Deltour	creation:	2024
guarantee:	two years	fabrication:	handmade in Autun, France
dimensions:	W.36 ^[CM] D.47.5 ^[CM] H.77 ^[CM]	material:	stainless steel
seat:	W.35.5 ^[CM] D.34.5 ^[CM] H.45.5 ^[CM]	finition:	available page 300
weight:	4.8 ^[KG]	use:	outdoor
highlights:	stackable up to 4 units	assembly:	assembled



Patio Slatted Chair, Galvanized

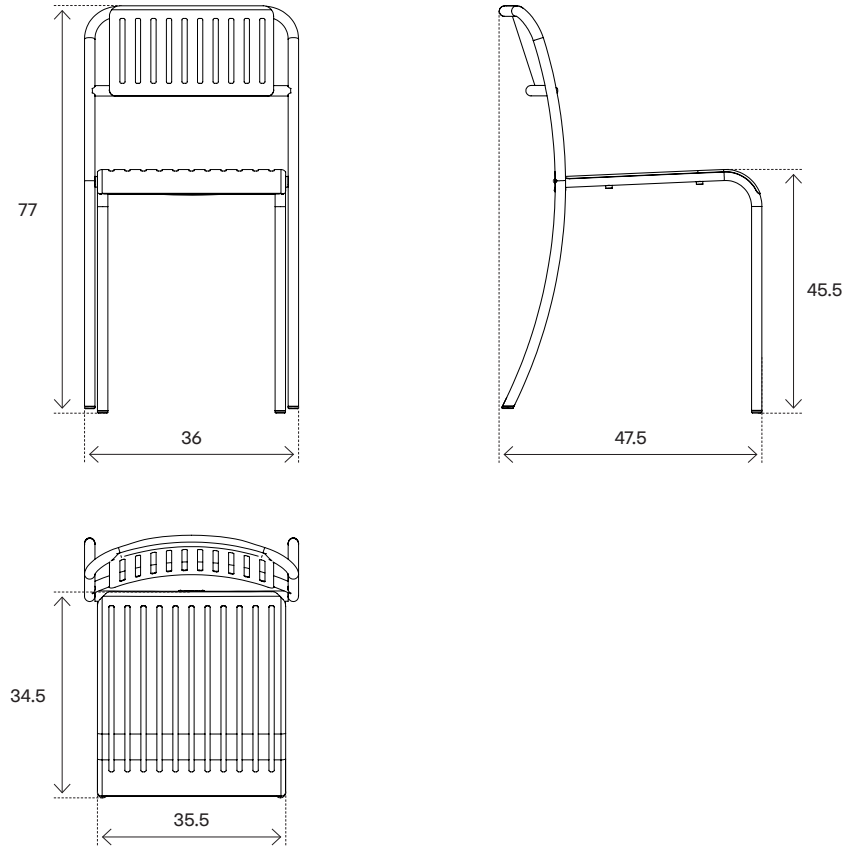

PATIO SLATTED CHAIR GALVANIZED

designer:	Pauline Deltour	creation:	2024
guarantee:	two years	fabrication:	handmade in Autun, France
dimensions:	W.36 ^[CM] D.47.5 ^[CM] H.77 ^[CM]	material:	steel
seat:	W.35.5 ^[CM] D.34.5 ^[CM] H.45.5 ^[CM]	finition:	galvanized
weight:	4.8 ^[KG]	use:	outdoor
highlights:	stackable up to 4 units	assembly:	assembled



Patio Solid Chair, *Pure White color*

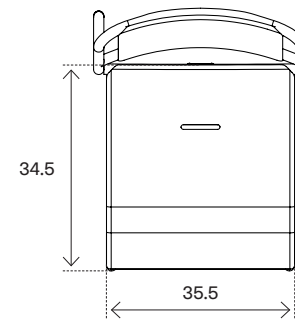
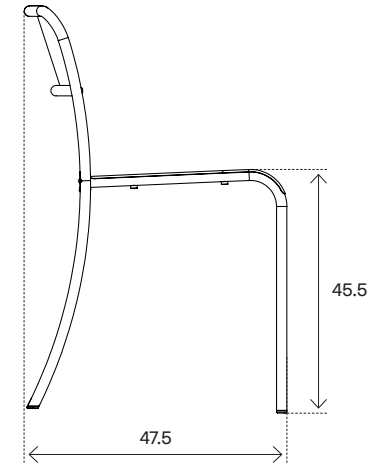
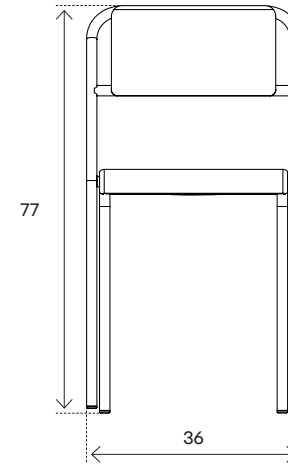

PATIO SOLID CHAIR

designer:	Pauline Deltour	creation:	2024
guarantee:	two years	fabrication:	handmade in Autun, France
dimensions:	W.36 ^[CM] D.47.5 ^[CM] H.77 ^[CM]	material:	stainless steel
seat:	W.35.5 ^[CM] D.34.5 ^[CM] H.45.5 ^[CM]	finition:	available page 300
weight:	4.39 ^[KG]	use:	outdoor
highlights:	stackable up to 4 units	assembly:	assembled



Patio Slatted Armchair, *Pure White color*

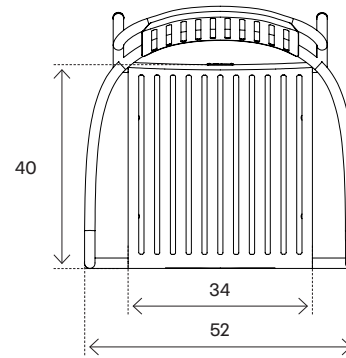
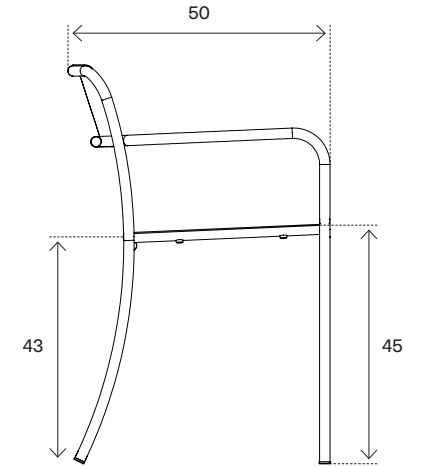
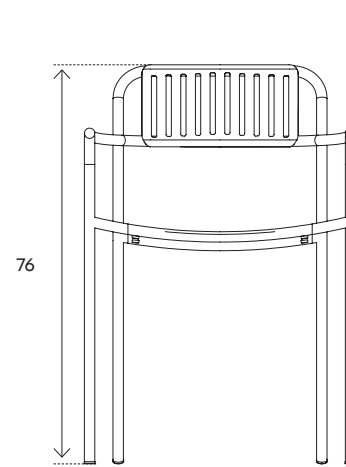

PATIO SLATTED ARMCHAIR

designer:	Pauline Deltour	creation:	2024
guarantee:	two years	fabrication:	handmade in Autun, France
dimensions:	W.52 ^[CM] D.50 ^[CM] H.76 ^[CM]	material:	stainless steel
seat:	W.34 ^[CM] D.40 ^[CM] H.45 ^[CM]	finition:	available page 300
weight:	5,0 ^[KG]	use:	outdoor
highlights:	stackable up to 4 units	assembly:	assembled

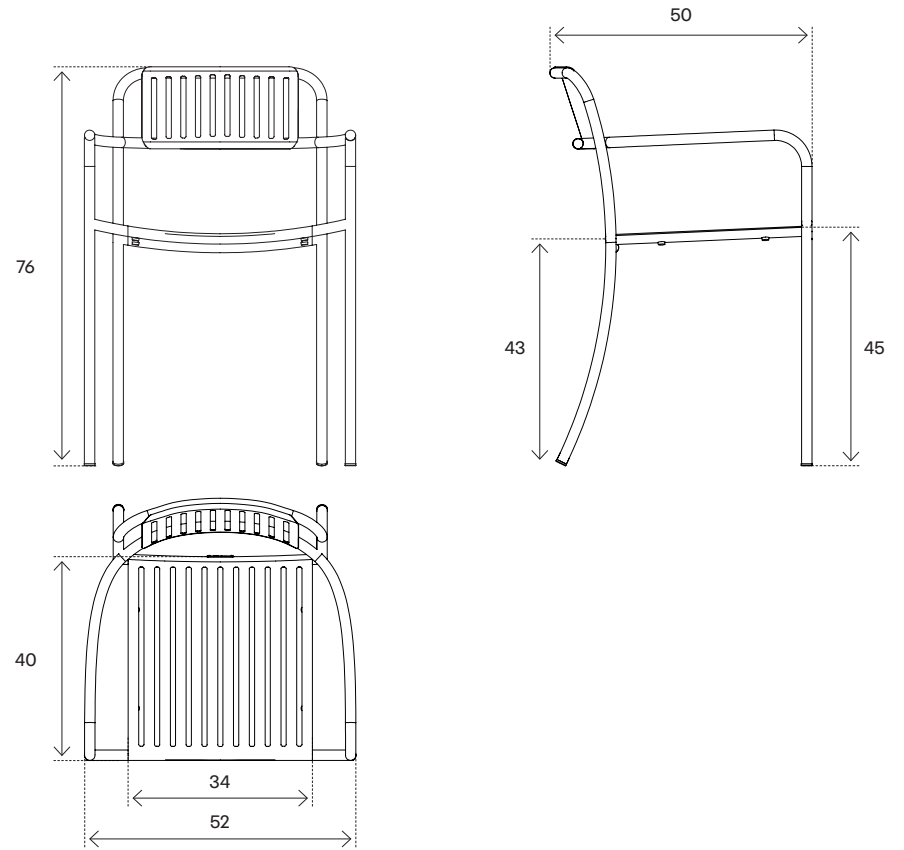
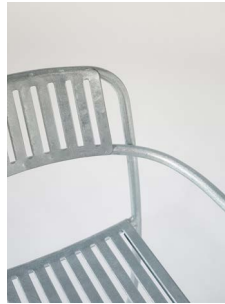

Patio Slatted Armchair, Galvanized

PATIO SLATTED ARMCHAIR GALVANIZED

designer:	Pauline Deltour	creation:	2024
guarantee:	two years	fabrication:	handmade in Autun, France
dimensions:	W.52 ^[CM] D.50 ^[CM] H.76 ^[CM]	material:	stainless steel steel
seat:	W.34 ^[CM] D.40 ^[CM] H.45 ^[CM]	finition:	galvanized
weight:	5,0 ^[KG]	use:	outdoor
highlights:	stackable up to 4 units	assembly:	assembled



Patio Solid Armchair, *Pure White* color

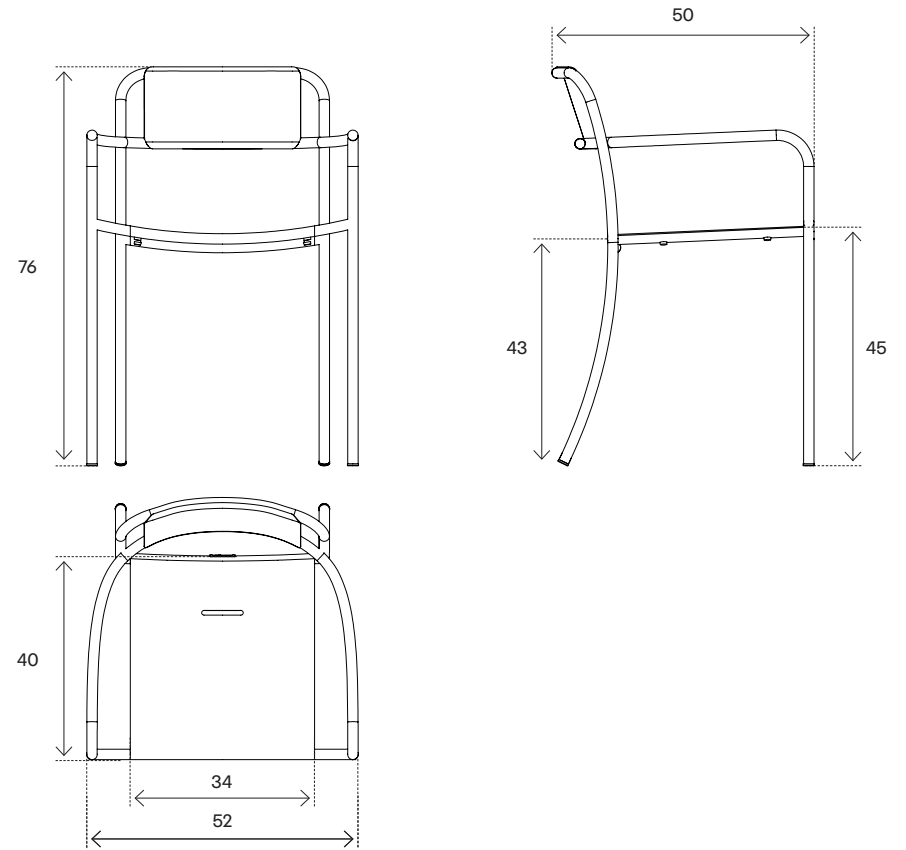

PATIO SOLID ARMCHAIR

designer:	Pauline Deltour	creation:	2024
guarantee:	two years	fabrication:	handmade in Autun, France
dimensions:	W.52 ^[CM] D.50 ^[CM] H.76 ^[CM]	material:	stainless steel
seat:	W.34 ^[CM] D.40 ^[CM] H.45 ^[CM]	finition:	available page 300
weight:	5,0 ^[KG]	use:	outdoor
highlights:	stackable up to 4 units	assembly:	assembled



Patio Lounge Slatted Armchair, *Pure White color*

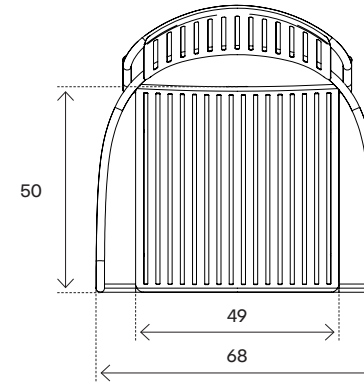
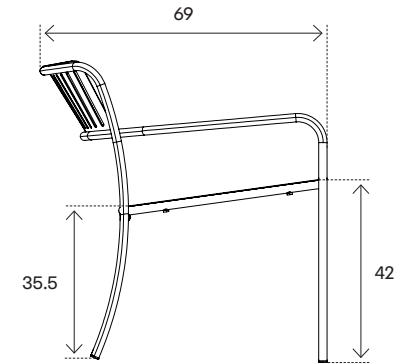
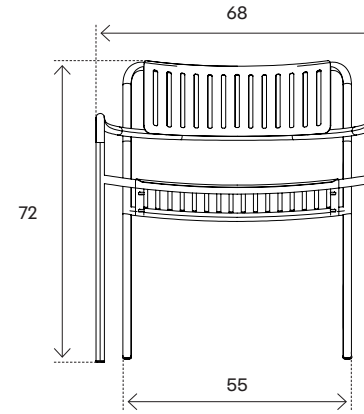

PATIO LOUNGE SLATTED ARMCHAIR

designer:	Pauline Deltour	creation:	2024
guarantee:	two years	fabrication:	handmade in Autun, France
dimensions:	W.68 ^[CM] D.69 ^[CM] H.72 ^[CM]	material:	stainless steel
seat:	W.49 ^[CM] D.50 ^[CM] H.42 ^[CM]	finition:	available page 300
weight:	6,5 ^[KG]	use:	outdoor
highlights:	stackable up to 4 units	assembly:	assembled



Patio Lounge Slatted Armchair, Galvanized

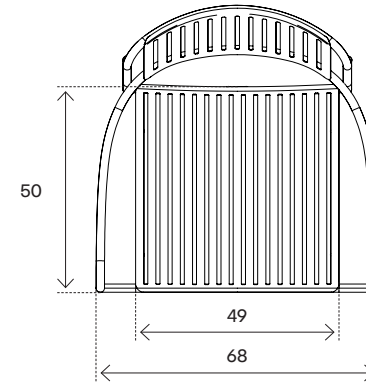
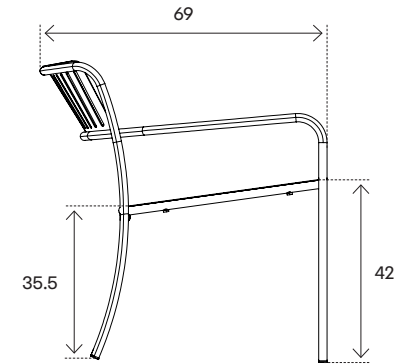
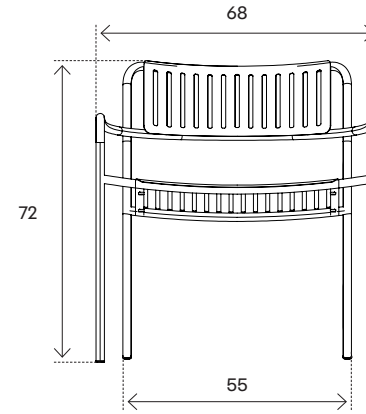

PATIO LOUNGE SLATTED ARMCHAIR GALVANIZED

designer:	Pauline Deltour	creation:	2024
guarantee:	two years	fabrication:	handmade in Autun, France
dimensions:	W.68 ^[CM] D.69 ^[CM] H.72 ^[CM]	material:	steel
seat:	W.49 ^[CM] D.50 ^[CM] H.42 ^[CM]	finition:	galvanized
weight:	6.5 ^[KG]	use:	outdoor
highlights:	stackable up to 4 units	assembly:	assembled



Patio Slatted High Chair, *Pure White color*

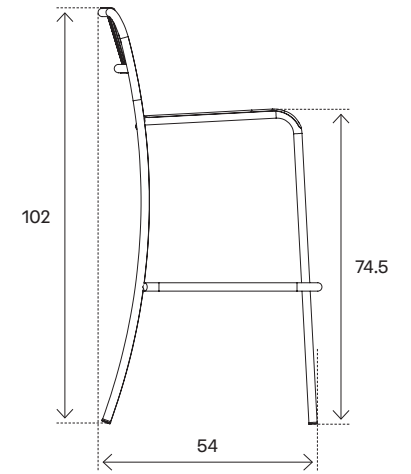
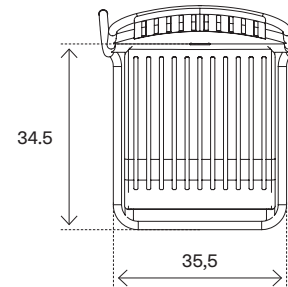
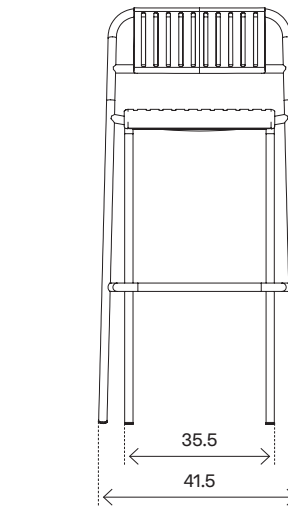

PATIO SLATTED HIGH CHAIR

designer:	Pauline Deltour	creation:	2024
guarantee:	two years	fabrication:	handmade in Autun, France
dimensions:	W.41.5 ^[CM] D.54 ^[CM] H.102 ^[CM]	material:	stainless steel
seat:	W.35.5 ^[CM] D.34.5 ^[CM] H.74.5 ^[CM]	finition:	available page 300
weight:	6.52 ^[KG]	use:	outdoor
highlights:	stackable up to 4 units	assembly:	assembled



Patio Slatted High Chair, Galvanized

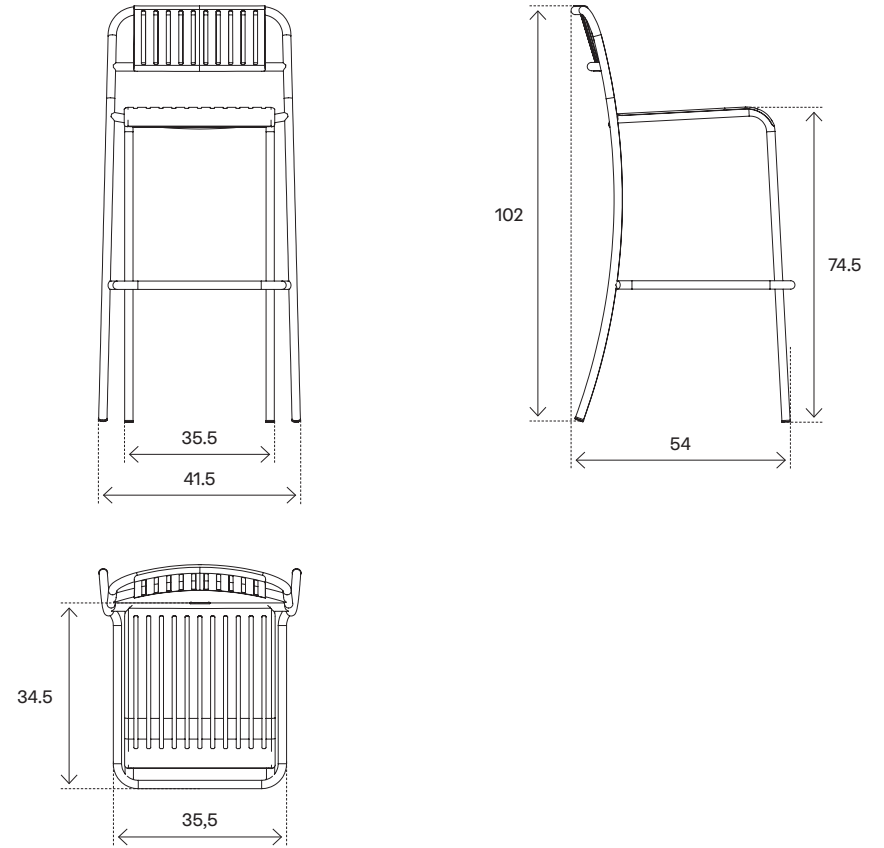

PATIO SLATTED HIGH CHAIR GALVANIZED

designer:	Pauline Deltour	creation:	2024
guarantee:	two years	fabrication:	handmade in Autun, France
dimensions:	W.41.5 ^[CM] D.54 ^[CM] H.102 ^[CM]	material:	steel
seat:	W.35.5 ^[CM] D.34.5 ^[CM] H.74.5 ^[CM]	finition:	galvanized
weight:	6.52 ^[KG]	use:	outdoor
highlights:	stackable up to 4 units	assembly:	assembled



Patio Slatted Stool, *Pure White* color

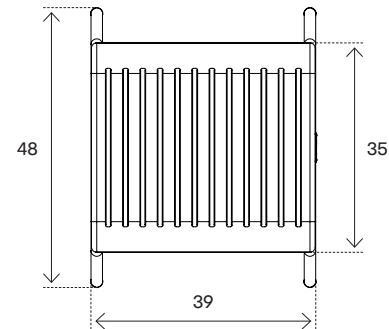
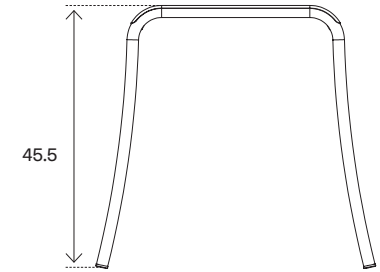
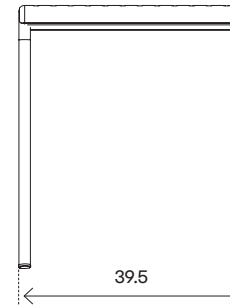

48

35

39

PATIO SLATTED STOOL

designer:	Pauline Deltour	creation:	2024
guarantee:	two years	fabrication:	handmade in Autun, France
dimensions:	W.39.5 ^[CM] D.48 ^[CM] H.45.5 ^[CM]	material:	stainless steel
seat:	W.39 ^[CM] D.35 ^[CM] H.45.5 ^[CM]	finition:	available page 300
weight:	3.25 ^[KG]	use:	outdoor
highlights:	not stackable	assembly:	assembled



Patio Slatted Stool, Galvanized

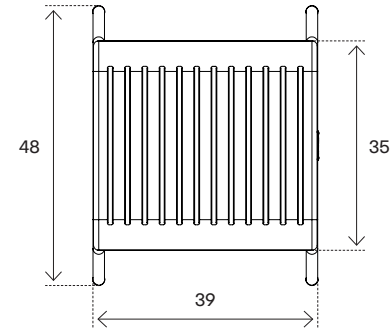
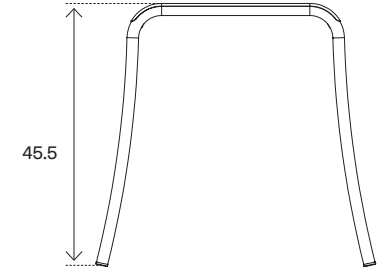
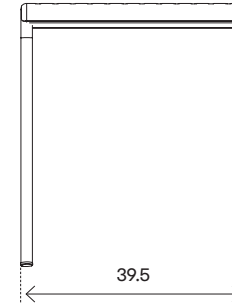

PATIO SLATTED STOOL GALVANIZED

designer:	Pauline Deltour	creation:	2024
guarantee:	two years	fabrication:	handmade in Autun, France
dimensions:	W.39.5 ^[CM] D.48 ^[CM] H.45.5 ^[CM]	material:	steel
seat:	W.39 ^[CM] D.35 ^[CM] H.45.5 ^[CM]	finition:	galvanized
weight:	3.25 ^[KG]	use:	outdoor
highlights:	not stackable	assembly:	assembled



Patio Slatted Ottoman, *Pure White color*

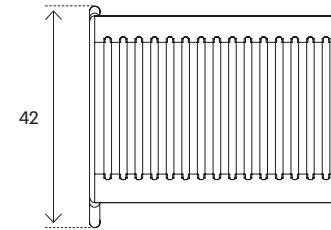
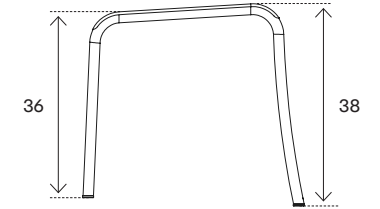
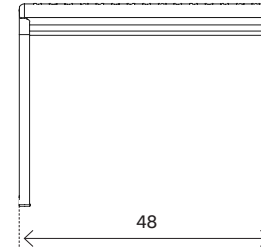

PATIO SLATTED OTTOMAN

designer:	Pauline Deltour	creation:	2024
guarantee:	two years	fabrication:	handmade in Autun, France
dimensions:	W.48 ^[CM] D.42 ^[CM] H.38 ^[CM]	material:	stainless steel
weight:	3.33 ^[KG]	finition:	available page 300
highlights:	non stackable	use:	outdoor
assembly:	assembled		



Patio Slatted Ottoman, Galvanized

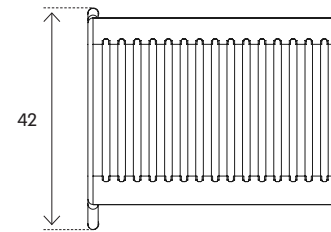
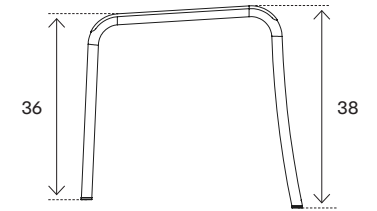
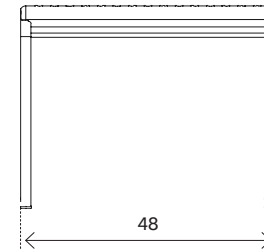

PATIO SLATTED OTTOMAN GALVANIZED

designer:	Pauline Deltour	creation:	2024
guarantee:	two years	fabrication:	handmade in Autun, France
dimensions:	W.48 ^[CM] D.42 ^[CM] H.38 ^[CM]	material:	steel
weight:	3.33 ^[KG]	finition:	galvanized
highlights:	non stackable	use:	outdoor
assembly:	assembled		



Patio Slatted Bench, *Pure White color*

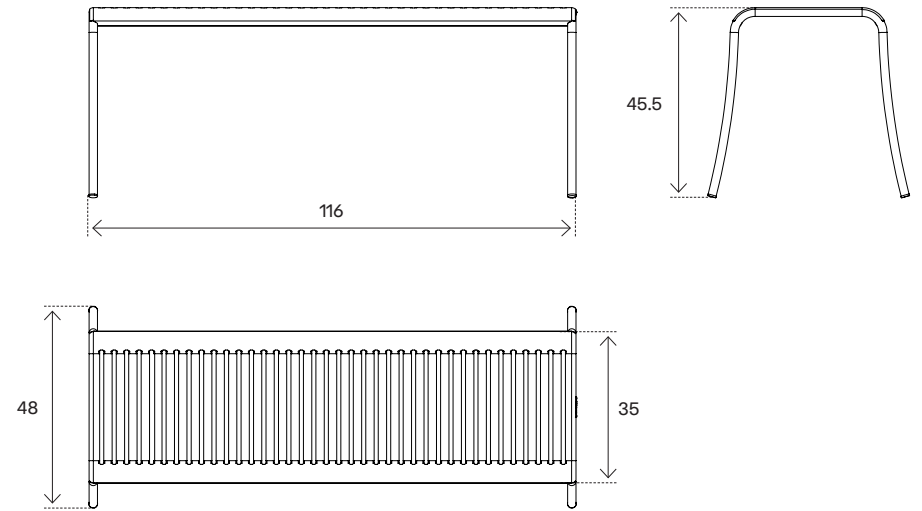

PATIO SLATTED BENCH

designer:	Pauline Deltour	creation:	2024
guarantee:	two years	fabrication:	handmade in Autun, France
dimensions:	W.116 ^[CM] D.48 ^[CM] H.45.5 ^[CM]	material:	stainless steel
seat:	W.116 ^[CM] D.35 ^[CM] H.45.5 ^[CM]	finition:	available page 300
weight:	7.79 ^[KG]	use:	outdoor
highlights:	non stackable	assembly:	assembled



Patio Slatted Bench, Galvanized

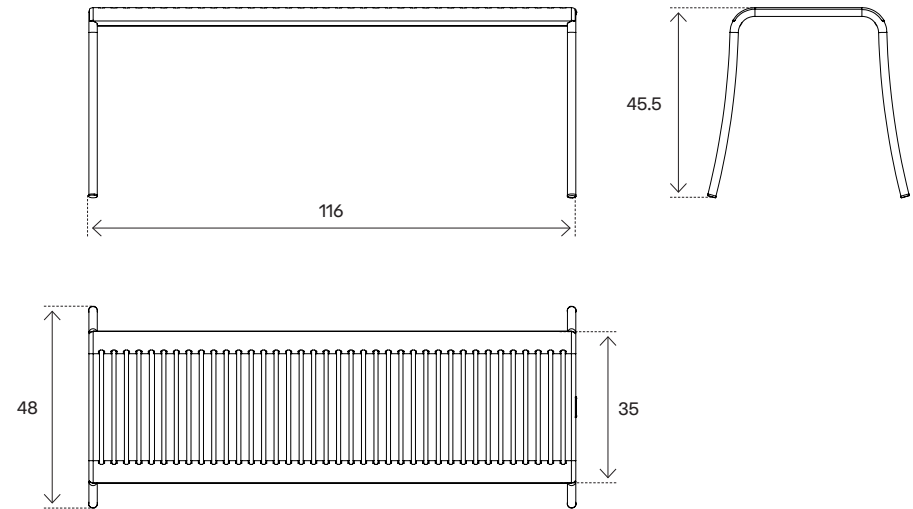

PATIO SLATTED BENCH GALVANIZED

designer:	Pauline Deltour	creation:	2024
guarantee:	two years	fabrication:	handmade in Autun, France
dimensions:	W.116 ^[CM] D.48 ^[CM] H.45.5 ^[CM]	material:	steel
seat:	W.116 ^[CM] D.35 ^[CM] H.45.5 ^[CM]	finition:	galvanized
weight:	7.79 ^[KG]	use:	outdoor
highlights:	non stackable	assembly:	assembled



Patio Slatted Back Bench, *Pure White color*

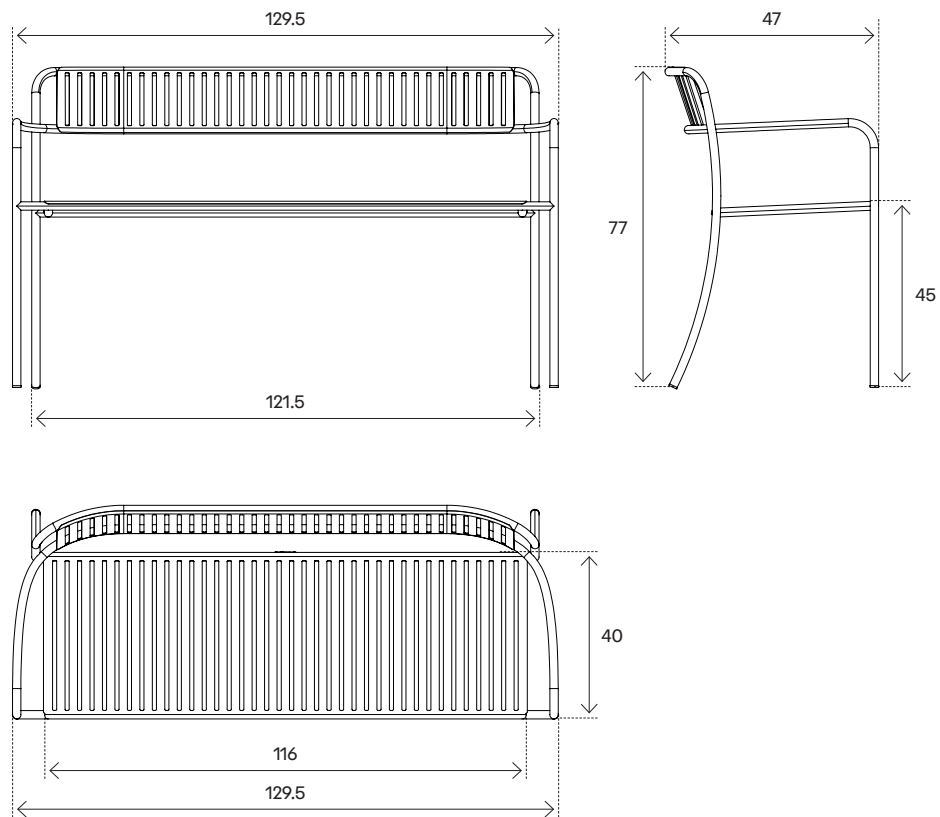

PATIO SLATTED BACK BENCH

designer:	Pauline Deltour	creation:	2024
guarantee:	two years	fabrication:	handmade in Autun, France
dimensions:	W.129.5 ^[CM] D.47 ^[CM] H.77 ^[CM]	material:	stainless steel
seat:	W.116 ^[CM] D.40 ^[CM] H.45 ^[CM]	finition:	available page 300
weight:	11,69 ^[KG]	use:	outdoor
highlights:	non stackable	assembly:	assembled



Patio Slatted Back Bench, Galvanized

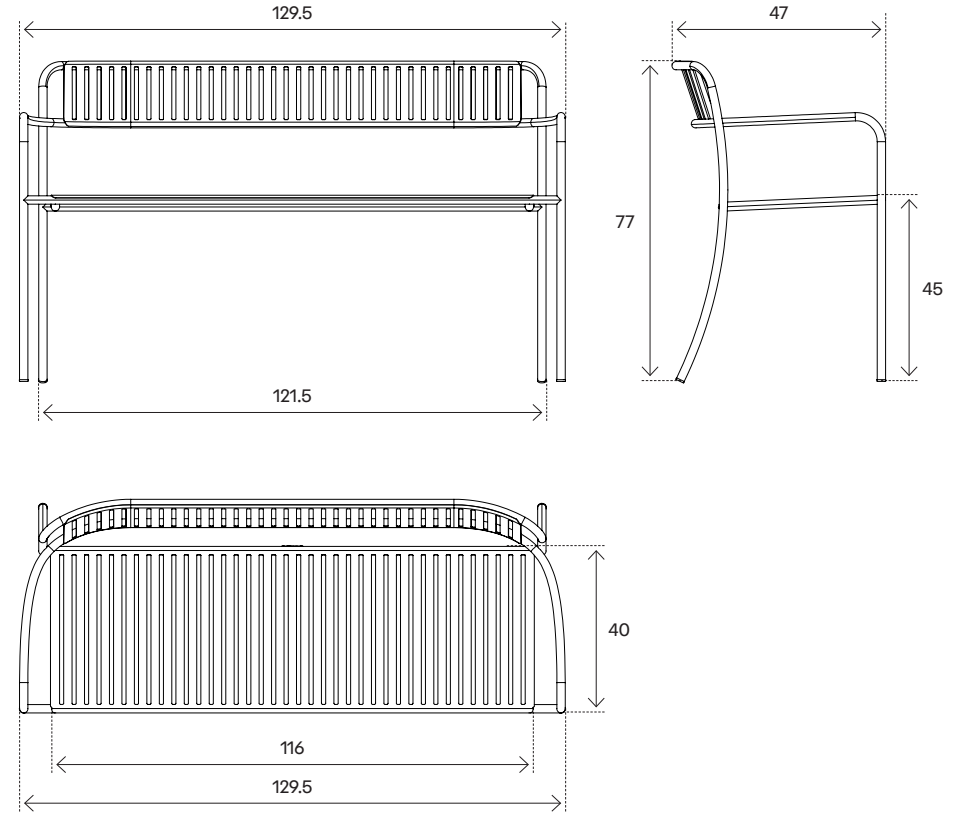

PATIO SLATTED BACK BENCH GALVANIZED

designer:	Pauline Deltour	creation:	2024
guarantee:	two years	fabrication:	handmade in Autun, France
dimensions:	W.129.5 ^[CM] D.47 ^[CM] H.77 ^[CM]	material:	steel
seat:	W.116 ^[CM] D.40 ^[CM] H.45 ^[CM]	finition:	galvanized
weight:	11,69 ^[KG]	use:	outdoor
highlights:	non stackable	assembly:	assembled

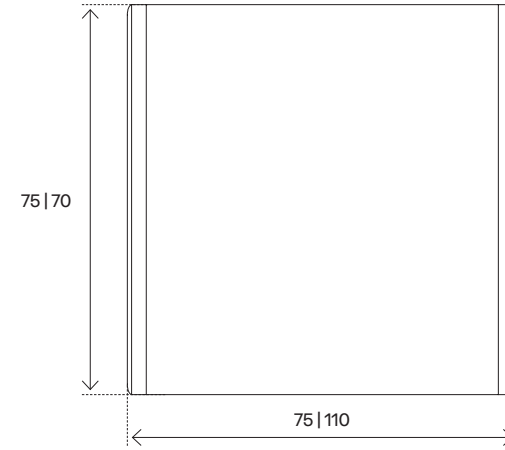
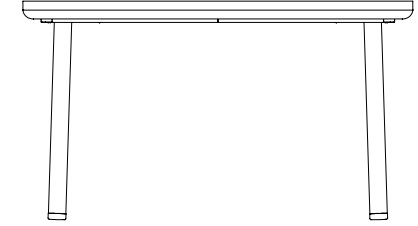
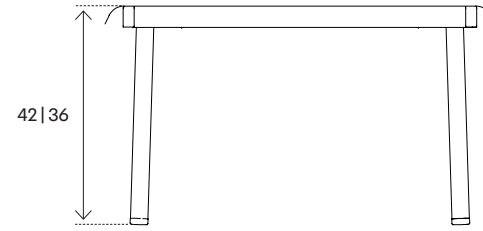

Patio Coffee Table dimensions [B], Pure White color

PATIO COFFEE TABLE

designer:	Pauline Deltour	creation:	2024
guarantee:	two years	fabrication:	handmade in Autun, France
dimensions* [A]:	W.75 [CM] D.75 [CM] H.42 [CM]	material:	stainless steel
weight:	11.83 [KG]	finition:	available page 300
highlights:	non stackable	use:	outdoor
assembly:	not assembled		

*other dimensions available: [B] L.110 [CM] W.70 [CM] H.36 [CM] | 16.45 [KG]

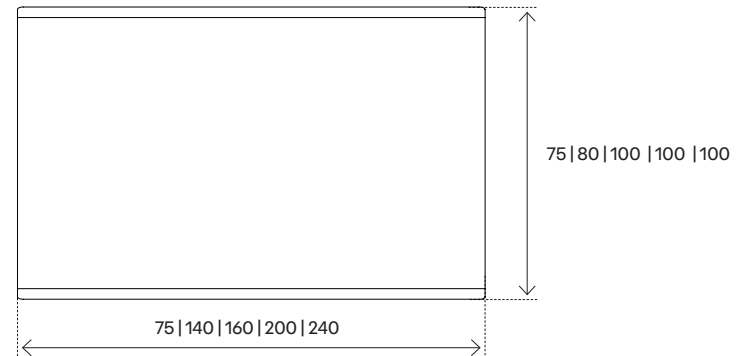
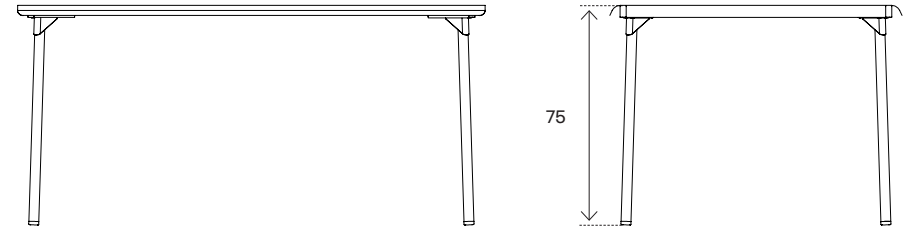

Patio Table dimensions ^[B], *Pure White* color

PATIO TABLE

designer:	Pauline Deltour	creation:	2024
guarantee:	two years	fabrication:	handmade in Autun, France
dimensions* ^[A] :	W.75 ^[CM] D.75 ^[CM] H.75 ^[CM]	material:	stainless steel
weight:	14,1 ^[KG]	finition:	available page 300
highlights:	non stackable	use:	outdoor
assembly:	not assembled		

*other dimensions available: [B] L.140 ^[CM] W.80 ^[CM] H.75 ^[CM] | 24,9 ^[KG] | [C] L.160 ^[CM] W.100 ^[CM] H.75 ^[CM] | 32 ^[KG] | [D] L.200 ^[CM] W.100 ^[CM] H.75 ^[CM] | 37 ^[KG] | [E] L.240 ^[CM] W.100 ^[CM] H.75 ^[CM] | 41,7 ^[KG]

ABC. COLLECTION

[ed. 2024]

Dans l'éclat de l'ère industrielle du début du XX^e siècle, Xavier Pauchard, visionnaire et artisan audacieux, a forgé un héritage remarquable avec ses premiers modèles emblématiques de meubles métalliques. Parmi ces créations pionnières, l'alphabet est d'usage pour qualifier et cartographier les modèles. A pour l'iconique Chaise A, C pour les casiers de bureau ou B pour les penderies vestiaires si emblématiques.

De l'univers du bureau à celui de la salle de sport, ces objets usuels, pensés dans une logique fonctionnaliste propre au mouvement moderniste des années 1930, ont su fusionner la forme et la fonction et répondent toujours à nos besoins de rangement en alliant élégance, simplicité et durabilité.^[FR]

In the radiance of the industrial era at the beginning of the 20th century, Xavier Pauchard, a visionary and bold artisan, forged a remarkable legacy with his first iconic models of metal furniture. Among these pioneering creations, the alphabet is used to qualify and map the models. A stands for the iconic A Chair, C for storage lockers, or B for the emblematic wardrobe lockers.

From the corporate environment to the fitness gym, these everyday objects, conceived in a functionalist logic inherent to the modernist movement of the 1930s, have successfully merged form and function and still meet our storage needs by combining elegance, simplicity, and durability.^[EN]

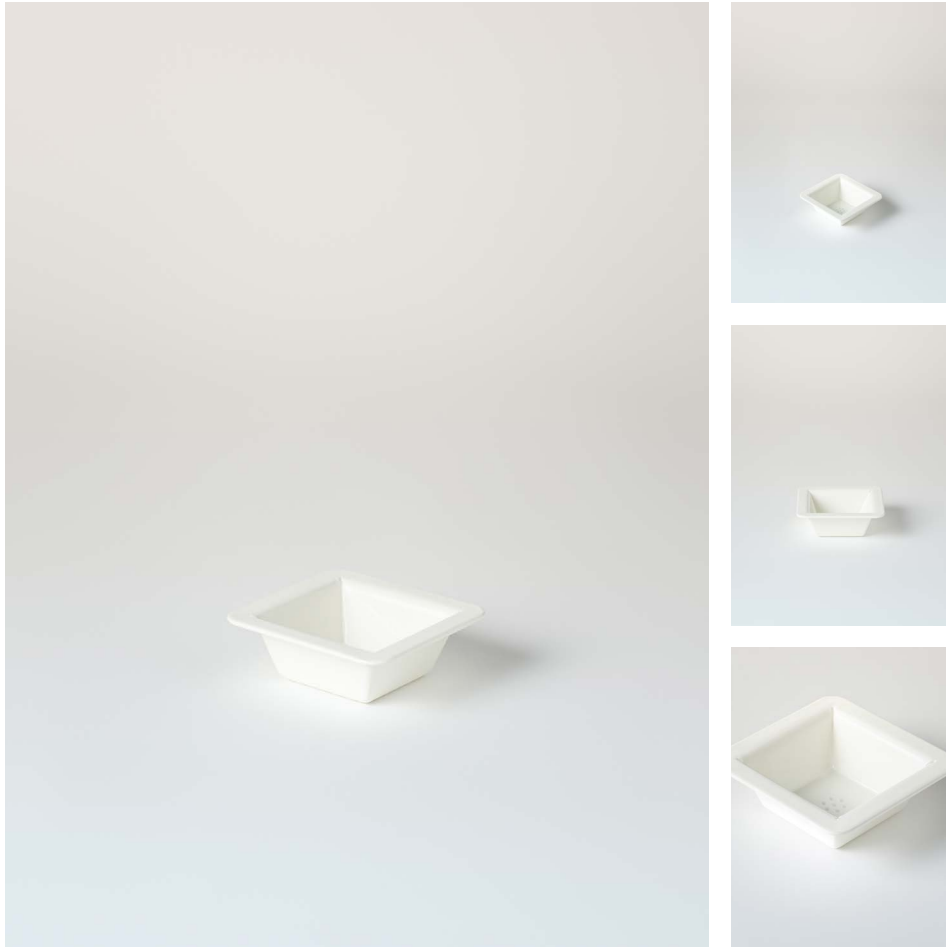
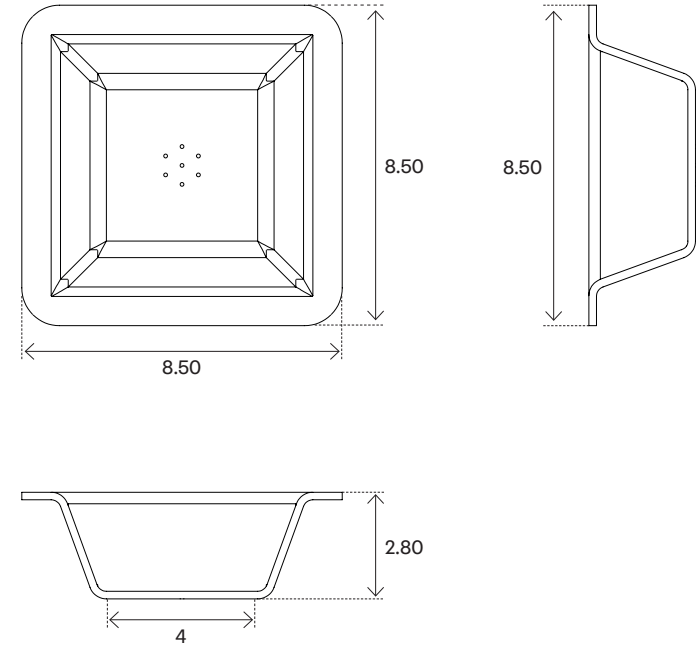

Square Storage Tray XS, *Pure White* color

SQUARE STORAGE TRAY XS

designer:	studio tolix	creation:	2024
guarantee:	two years	fabrication:	handmade in Autun, France
dimensions:	L.8.50 [CM] W. 8.50 [CM] H.2.80 [CM]	material:	steel
weight:	0.16 [KG]	finition:	available page 300
highlight:	stackable	use:	indoor
assembly:	assembled		



Storage Tray M, Pure White color

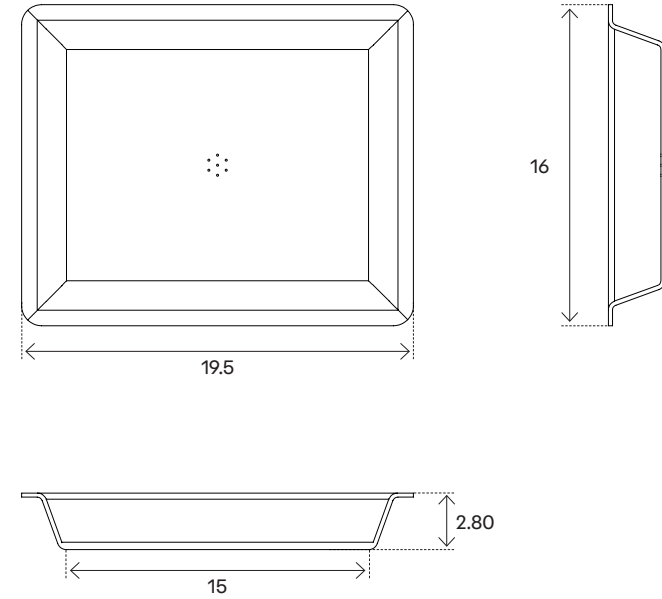

STORAGE TRAY M

designer:	studio tolix	creation:	2024
guarantee:	two years	fabrication:	handmade in Autun, France
dimensions:	L. 19.5 [CM] W. 16 [CM] H. 2.80 [CM]	material:	steel
weight:	0.64 [KG]	finition:	available page 300
highlight:	stackable	use:	indoor
assembly:	assembled		



Storage tray M, Raw Steel Varnished

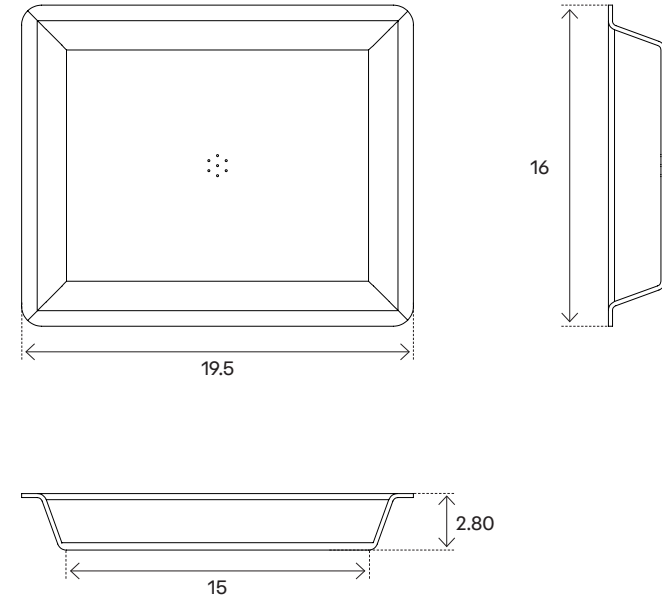

STORAGE TRAY M VARNISHED

designer:	studio tolix	creation:	2024
guarantee:	two years	fabrication:	handmade in Autun, France
dimensions:	L.19.5 [CM] W. 16 [CM] H. 2.80 [CM]	material:	steel
weight:	0.64 [KG]	finition:	varnished raw steel
highlight:	stackable	use:	indoor
assembly:	assembled		



Metal Box S, Pure White color

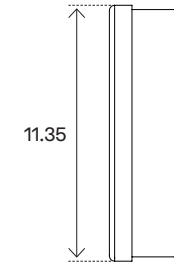
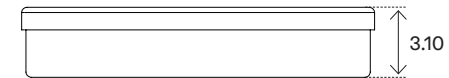
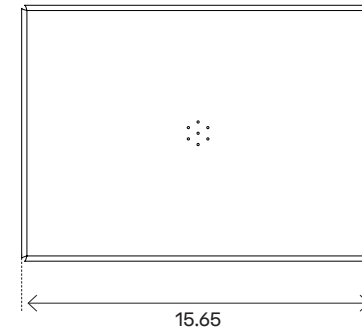

METAL BOX S

designer:	studio tolix	creation:	2024
guarantee:	two years	fabrication:	handmade in Autun, France
dimensions:	L.15.65 [CM] W.11.35 [CM] H.3.10 [CM]	material:	steel
weight:	0.32 [KG]	finition:	available page 300
assembly:	assembled	use:	indoor



Metal Box S, Raw Steel Varnished

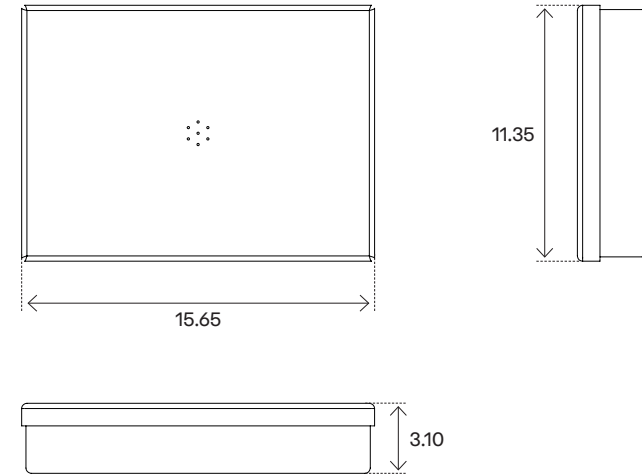

METAL BOX S VARNISHED

designer:	studio tolix	creation:	2024
guarantee:	two years	fabrication:	handmade in Autun, France
dimensions:	L.15.65 ^[CM] W.11.35 ^[CM] H.3.10 ^[CM]	material:	steel
weight:	0.32 ^[KG]	finition:	varnished raw steel
assembly:	assembled	use:	indoor



Metal Box M, Pure White color

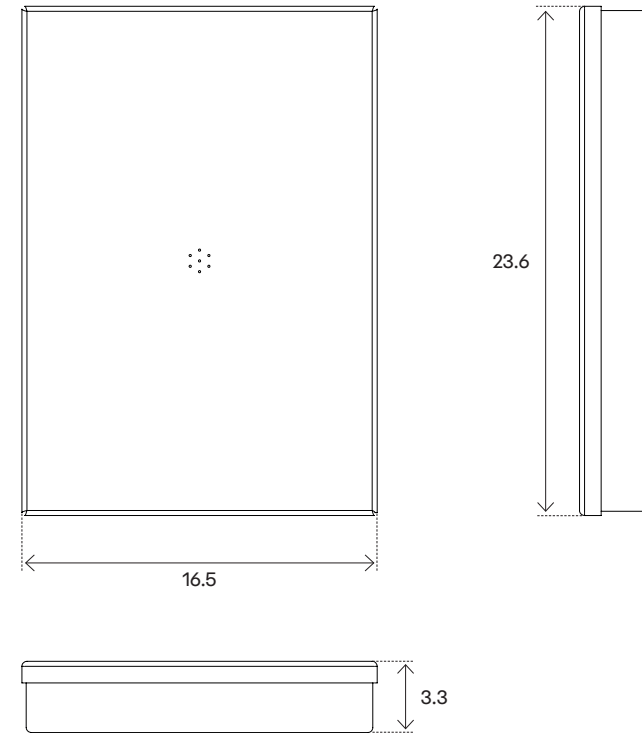

METAL BOX M

designer:	studio tolix	creation:	2024
guarantee:	two years	fabrication:	handmade in Autun, France
dimensions:	L.23.6 [CM] W.16.5 [CM] H. 3.3 [CM]	material:	steel
weight:	0.76 [KG]	finition:	available page 300
assembly:	assembled	use:	indoor

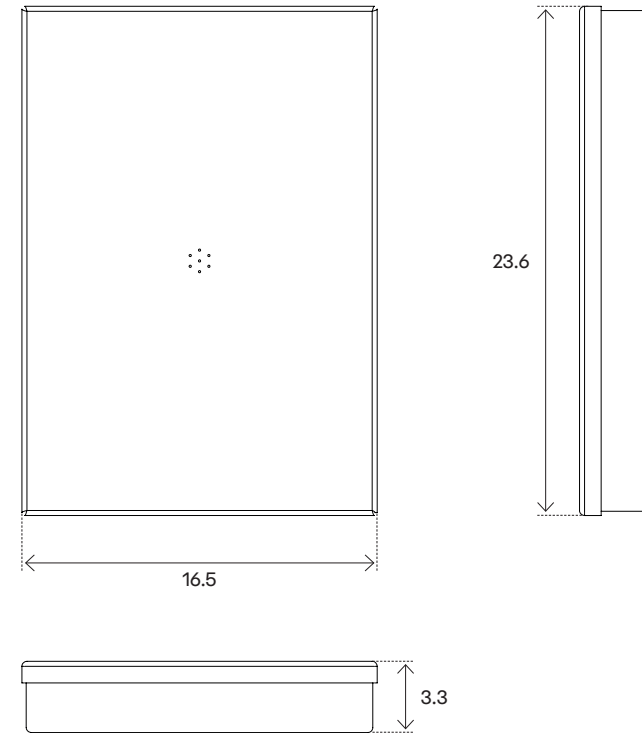
Metal Box M, *Raw Steel Varnished*

METAL BOX M VARNISHED

designer:	studio tolix	creation:	2024
guarantee:	two years	fabrication:	handmade in Autun, France
dimensions:	L.23.6 [CM] W.16.5 [CM] H. 3.3 [CM]	material:	steel
weight:	0.76 [KG]	finition:	varnished raw steel
assembly:	assembled	use:	indoor



Metal Box L, Pure White color

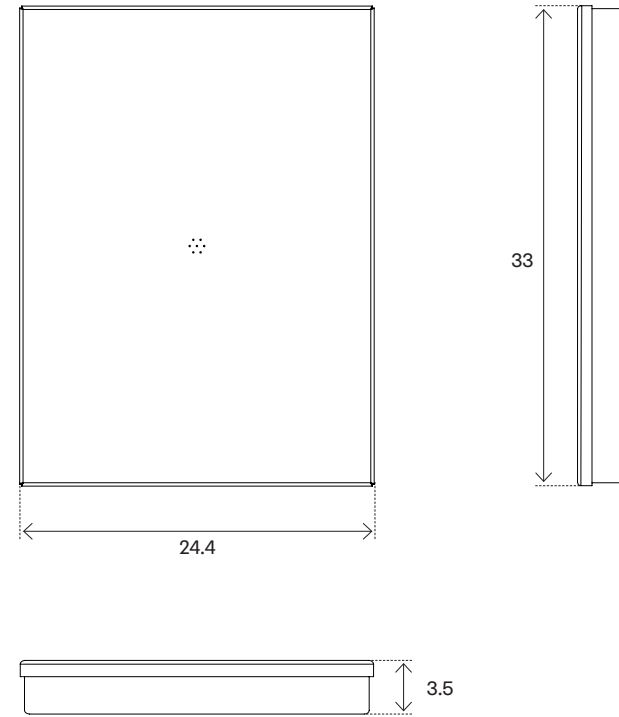

METAL BOX L

designer:	studio tolux	creation:	2024
guarantee:	two years	fabrication:	handmade in Autun, France
dimensions:	L.33 [CM] W.24.4 [CM] H.3.5 [CM]	material:	steel
weight:	1.5 [KG]	finition:	available page 300
assembly:	assembled	use:	indoor



Metal Box L, Raw Steel Varnished

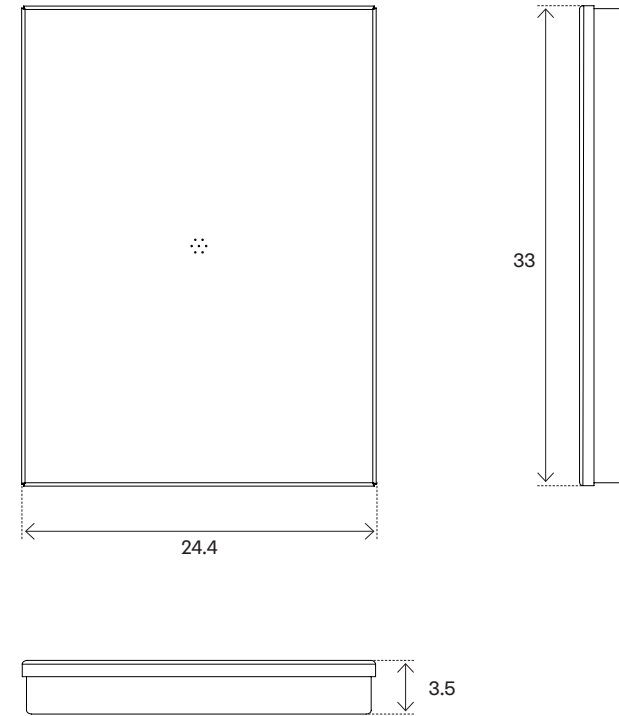

METAL BOX L VARNISHED

designer:	studio tolux	creation:	2024
guarantee:	two years	fabrication:	handmade in Autun, France
dimensions:	L.33 [CM] W.24.4 [CM] H.3.5 [CM]	material:	steel
weight:	1.5 [KG]	finition:	varnished raw steel
assembly:	assembled	use:	indoor



A Chair, Pure White color

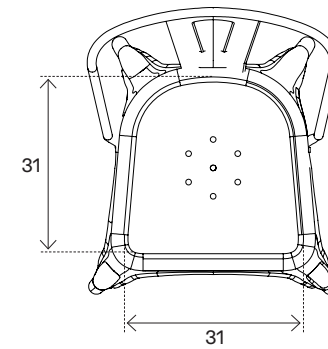
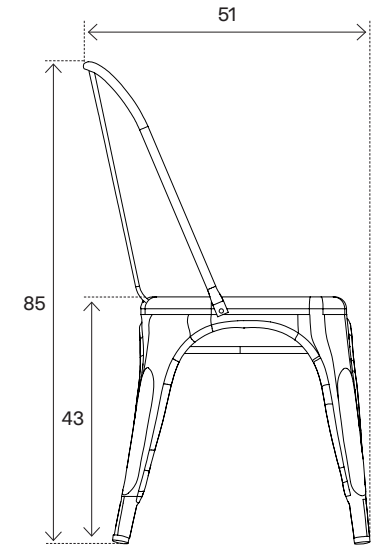
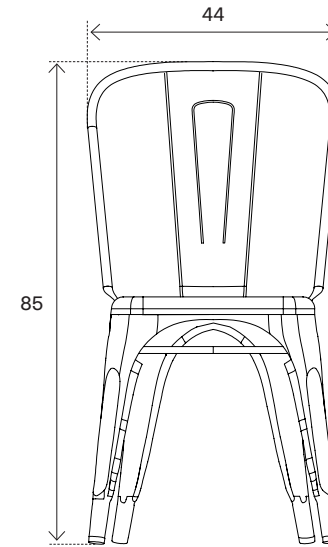

A CHAIR

designer:	Xavier Pauchard	creation:	1947
guarantee:	two years	fabrication:	handmade in Autun, France
dimensions:	W.44 [CM] D.51 [CM] H.85 [CM]	material:	steel
seat:	W.41 [CM] D.35 [CM] H.43 [CM]	finition:	available page 300
weight:	4.5 [KG]	use:	indoor
highlight:	stackable up to 8 units	assembly:	assembled



A Chair, Galvanized

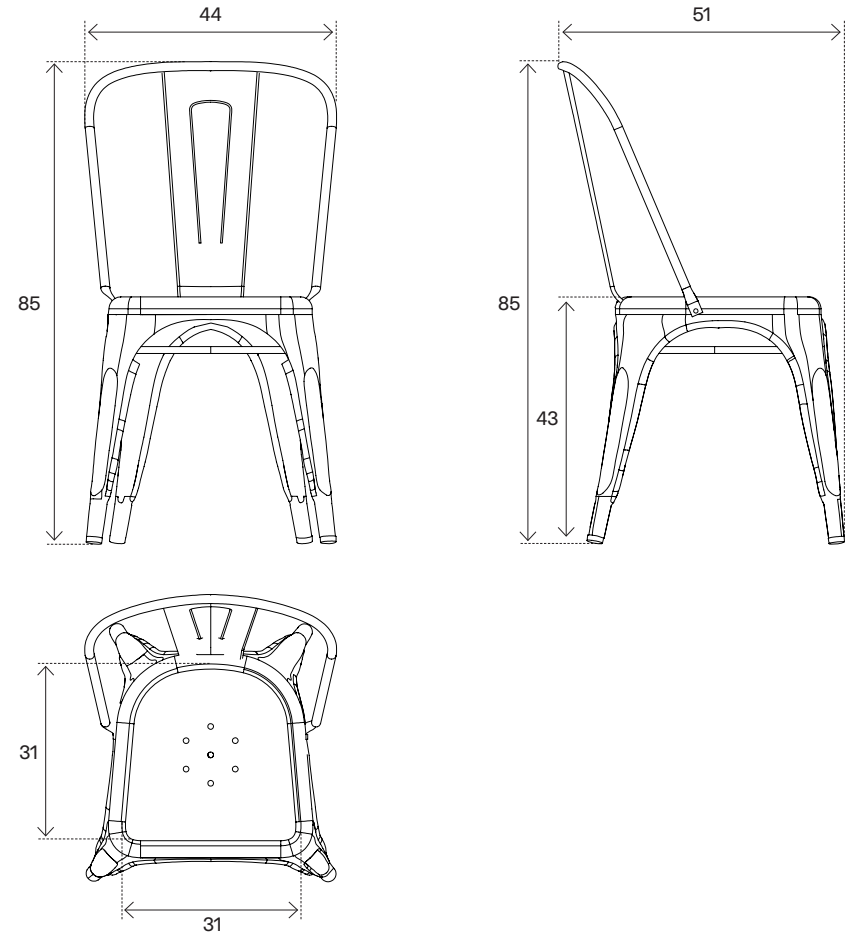

A CHAIR GALVANIZED

designer:	Xavier Pauchard	creation:	1947
guarantee:	two years	fabrication:	handmade in Autun, France
dimensions:	W.44 [CM] D.51 [CM] H.85 [CM]	material:	steel
seat:	W.41 [CM] D.35 [CM] H.43 [CM]	finition:	galvanized
weight:	4.5 [KG]	use:	outdoor
highlight:	stackable up to 8 units	assembly:	assembled



A Chair, Raw Steel Varnished

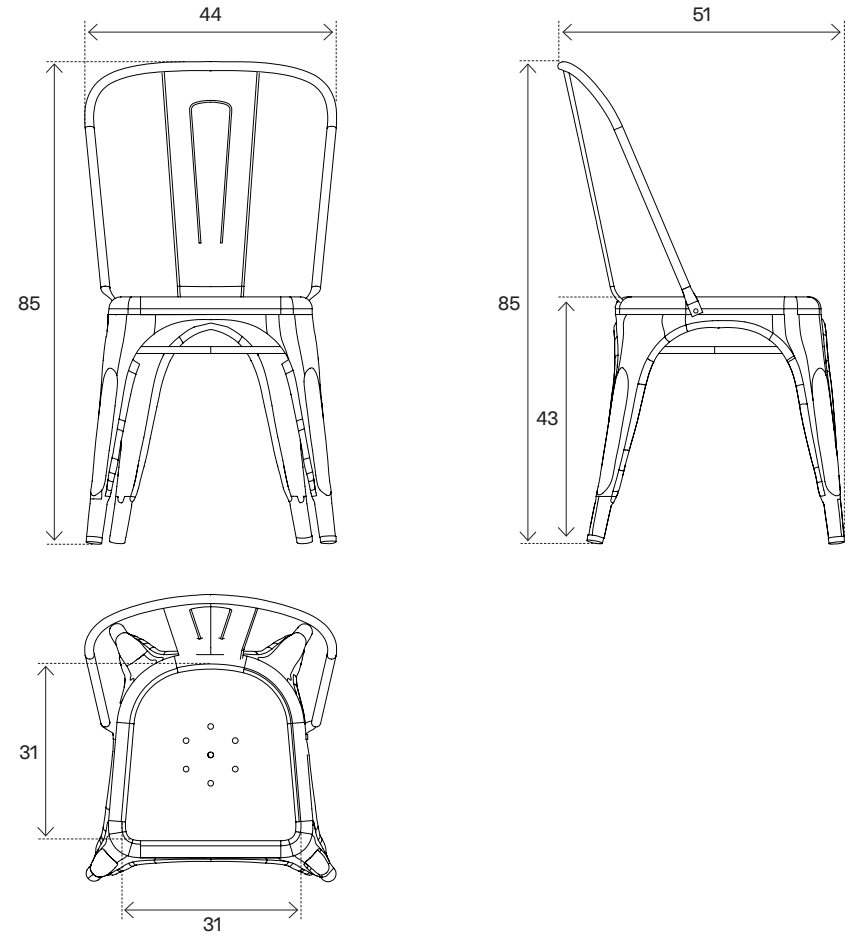

A CHAIR VARNISHED

designer:	Xavier Pauchard	creation:	1947
guarantee:	two years	fabrication:	handmade in Autun, France
dimensions:	W.44 [CM] D.51 [CM] H.85 [CM]	material:	steel
seat:	W.41 [CM] D.35 [CM] H.43 [CM]	finition:	Raw Steel Varnished
weight:	4.5 [KG]	use:	outdoor
highlight:	stackable up to 8 units	assembly:	assembled

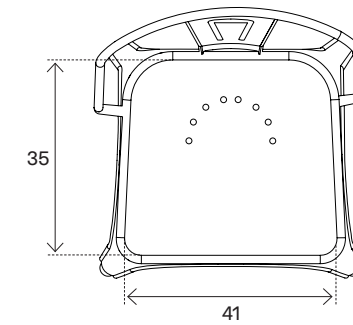
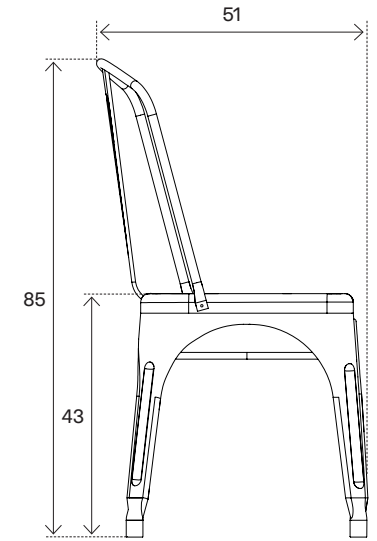
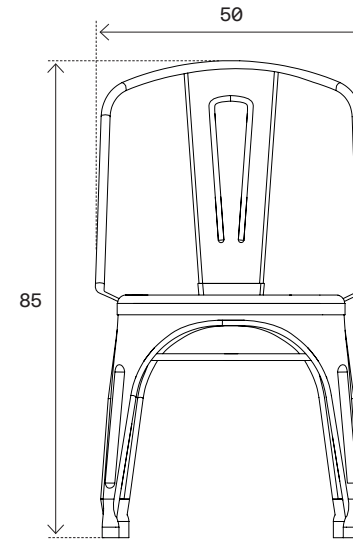
AC Chair, *Pure White color*

AC CHAIR

designer:	Xavier Pauchard	creation:	1947
guarantee:	two years	fabrication:	handmade in Autun, France
dimensions:	W.50 [CM] D.51 [CM] H.85 [CM]	material:	steel
seat:	W.41 [CM] D.35 [CM] H.43 [CM]	finition:	available page 300
weight:	4.9 [KG]	use:	indoor
highlight:	stackable up to 8 units	assembly:	assembled



AC Chair, Raw Steel Varnished

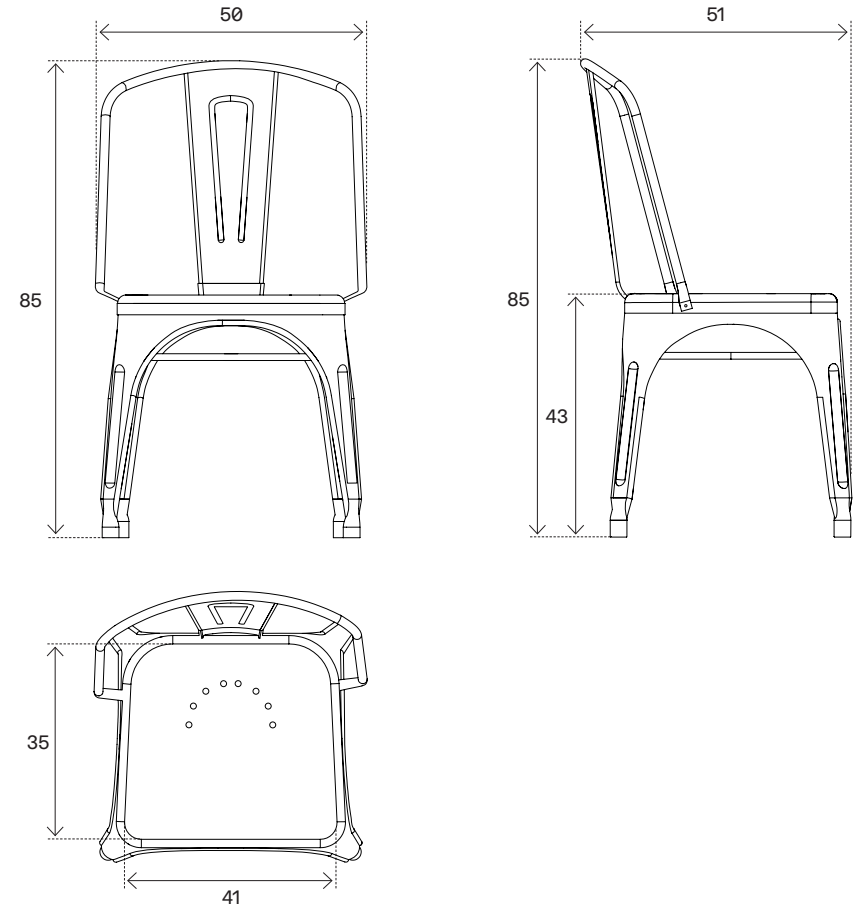

AC CHAIR VARNISHED

designer:	Xavier Pauchard	creation:	1947
guarantee:	two years	fabrication:	handmade in Autun, France
dimensions:	W.50 [CM] D.51 [CM] H.85 [CM]	material:	steel
seat:	W.41 [CM] D.35 [CM] H.43 [CM]	finition:	varnished raw steel
weight:	4.9 [KG]	use:	indoor
highlight:	stackable up to 8 units	assembly:	assembled



AC Chair, Galvanized

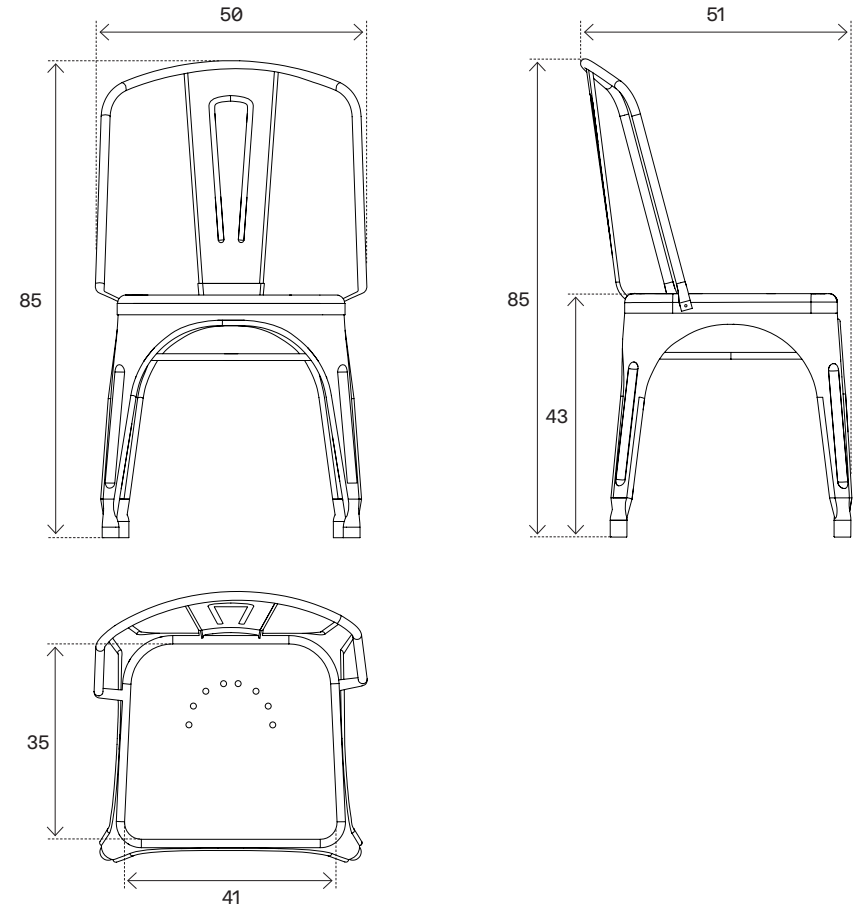

AC CHAIR GALVANIZED

designer:	Xavier Pauchard	creation:	1947
guarantee:	two years	fabrication:	handmade in Autun, France
dimensions:	W.50 [CM] D.51 [CM] H.85 [CM]	material:	steel
seat:	W.41 [CM] D.35 [CM] H.43 [CM]	finition:	varnished raw steel
weight:	4.9 [KG]	use:	indoor outdoor
highlight:	stackable up to 8 units	assembly:	assembled



AC16 Armchair, Pure White color

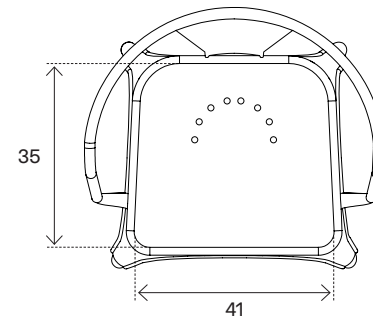
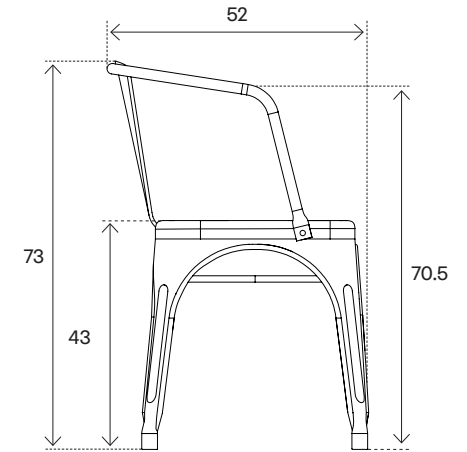
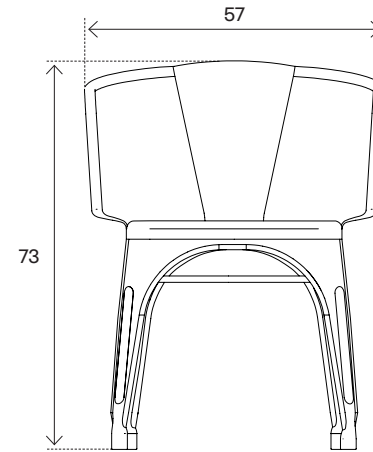

AC16 ARMCHAIR

designer:	Studio Tolix	creation:	2016
guarantee:	two years	fabrication:	handmade in Autun, France
dimensions:	W.57 [CM] D.52 [CM] H.73 [CM]	material:	steel
seat:	W.41 [CM] D.35 [CM] H.43 [CM]	finition:	available page 300
armrests:	H.70.5 [CM]	use:	indoor
weight:	5.0 [KG]	assembly:	assembled
highlight:	stackable up to 8 units		



AC16 Armchair, Raw Steel Varnished

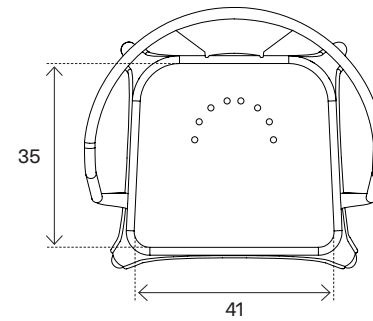
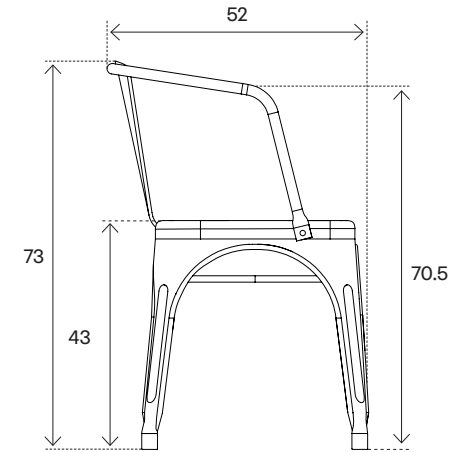
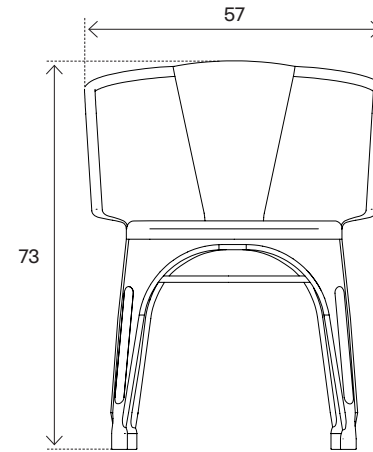

AC16 ARMCHAIR VARNISHED

designer:	Studio Tolix	creation:	2016
guarantee:	two years	fabrication:	handmade in Autun, France
dimensions:	W.57 [CM] D.52 [CM] H.73 [CM]	material:	steel
seat:	W.41 [CM] D.35 [CM] H.43 [CM]	finition:	varnished raw steel
armrests:	H.70.5 [CM]	use:	indoor
weight:	5.0 [KG]	assembly:	assembled
highlight:	stackable up to 8 units		



AC16 Armchair, Galvanized

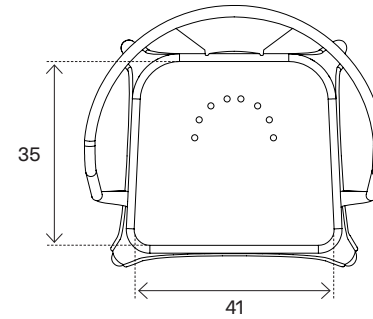
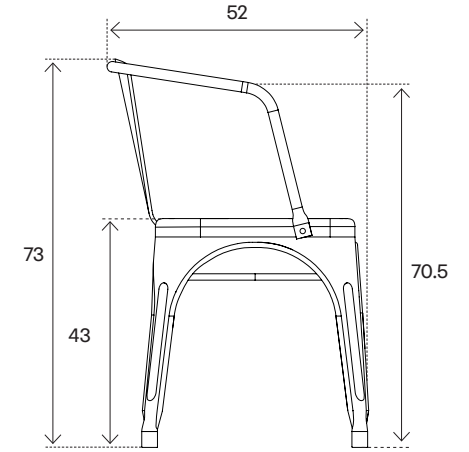
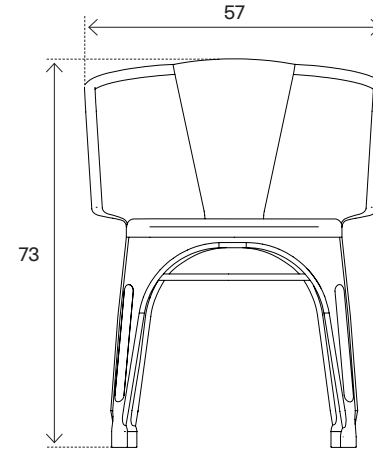

AC16 ARMCHAIR GALVANIZED

designer:	Studio Tolix	creation:	2016
guarantee:	two years	fabrication:	handmade in Autun, France
dimensions:	W.57 [CM] D.52 [CM] H.73 [CM]	material:	steel
seat:	W.41 [CM] D.35 [CM] H.43 [CM]	finition:	galvanized
armrests:	H.70.5 [CM]	use:	indoor outdoor
weight:	5.0 [KG]	assembly:	assembled
highlight:	stackable up to 8 units		

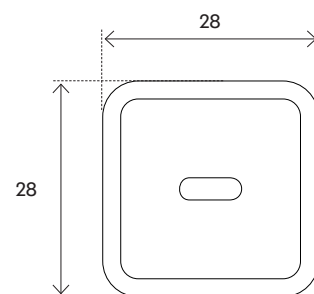
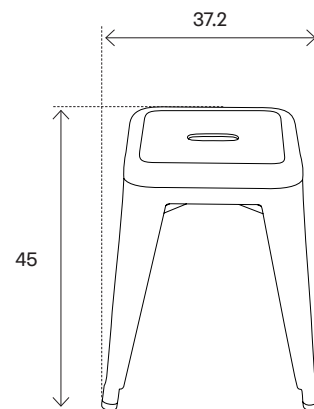
H 45 Stool, *Pure White* color

H 45 INDOOR STOOL

designer:	Xavier Pauchard	creation:	1937
guarantee:	two years	fabrication:	handmade in Autun, France
dimensions:	W.37.2 [CM] D.37.2 [CM] H.45 [CM]	material:	steel
seat:	W.28 [CM] D.28 [CM] H.45 [CM]	finition:	available page 300
weight:	3,4 [KG]	use:	indoor
highlight:	stackable up to 4 units	assembly:	assembled

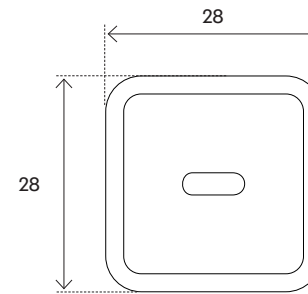
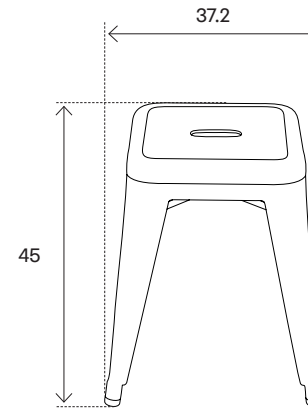
H 45 Stool, *Raw Steel Varnished*

H 45 INDOOR STOOL VARNISHED

designer:	Xavier Pauchard	creation:	1937
guarantee:	two years	fabrication:	handmade in Autun, France
dimensions:	W.37.2 [CM] D.37.2 [CM] H.45 [CM]	material:	steel
seat:	W.28 [CM] D.28 [CM] H.45 [CM]	finition:	raw steel varnished
weight:	3,4 [KG]	use:	indoor
highlight:	stackable up to 4 units	assembly:	assembled

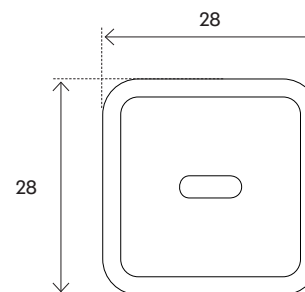
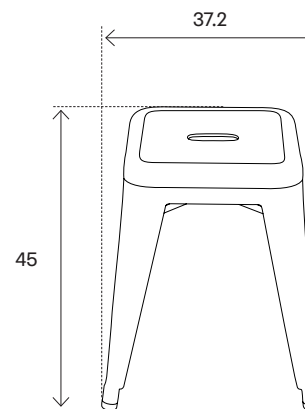
H 45 Stool, *Pure White color*

H 45 OUTDOOR STOOL

designer:	Xavier Pauchard	creation:	1937
guarantee:	two years	fabrication:	handmade in Autun, France
dimensions:	W.37.2 [CM] D.37.2 [CM] H.45 [CM]	material:	steel
seat:	W.28 [CM] D.28 [CM] H.45 [CM]	finition:	available page 300
weight:	3,4 [KG]	use:	outdoor
highlight:	stackable up to 4 units	assembly:	assembled



H 45 Stool, Galvanized

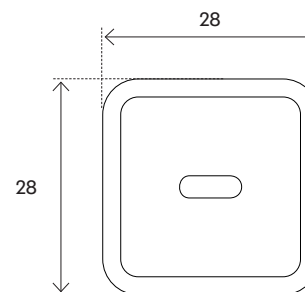
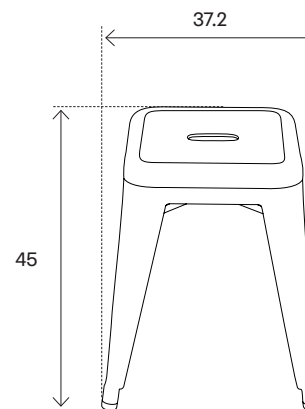

H 45 STOOL GALVANIZED

designer:	Xavier Pauchard	creation:	1937
guarantee:	two years	fabrication:	handmade in Autun, France
dimensions:	W.37.2 [CM] D.37.2 [CM] H.45 [CM]	material:	steel
seat:	W.28 [CM] D.28 [CM] H.45 [CM]	finition:	galvanized
weight:	3,4 [KG]	use:	outdoor
highlight:	stackable up to 4 units	assembly:	assembled

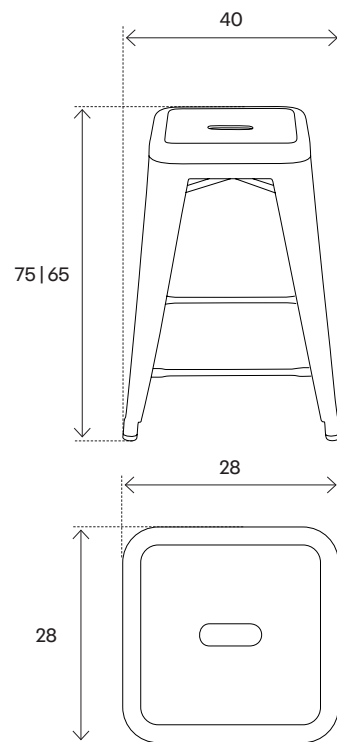

H 65 Stool, Pure White color



dimensions:	H.65 [CM]	H 75 [CM]
width:	40 [CM]	43.5 [CM]
height:	65 [CM]	75 [CM]
depth:	40 [CM]	43.5 [CM]
weight:	4.95 [KG]	5.4 [CM]

H 65 | H 75 INDOOR STOOL

designer:	Xavier Pauchard	creation:	1937
guarantee:	two years	fabrication:	handmade in Autun, France
highlight:	stackable	material:	steel
assembly:	assembled	finition:	available page 300
		use:	indoor



H 65 Stool, Raw Steel Varnished

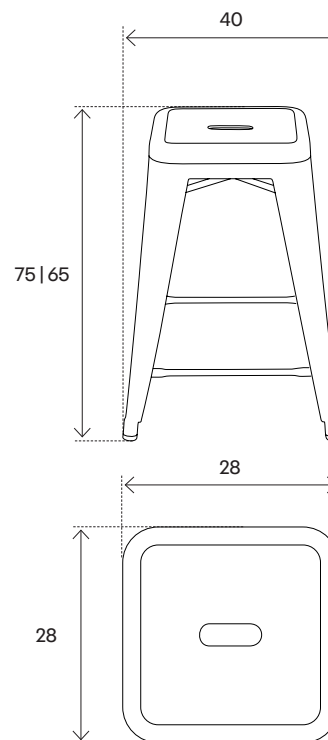

dimensions:	H.65	H 75
width:	40 [CM]	43.5 [CM]
height:	65 [CM]	75 [CM]
depth:	40 [CM]	43.5 [CM]
weight:	4.95 [KG]	5.4 [CM]

H 65 | H 75 INDOOR STOOL VARNISHED

designer:	Xavier Pauchard	creation:	1937
guarantee:	two years	fabrication:	handmade in Autun, France
highlight:	stackable	material:	steel
assembly:	assembled	finitions:	raw steel varnished
		use:	indoor



H 65 Stool, Pure White color

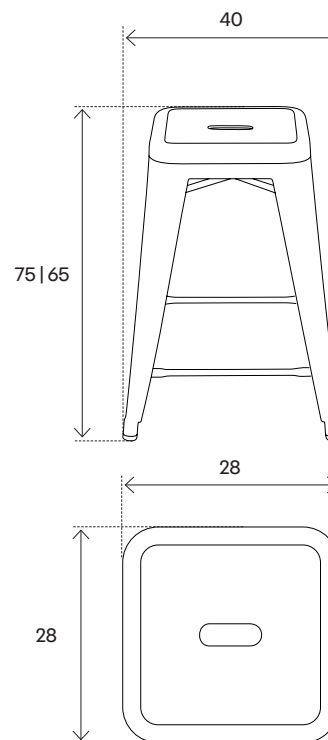

dimensions:	H.65	H 75
width:	40 [CM]	43.5 [CM]
height:	65 [CM]	75 [CM]
depth:	40 [CM]	43.5 [CM]
weight:	4.95 [KG]	5.4 [CM]

H 65 | H 75 OUTDOOR STOOL

designer:	Xavier Pauchard	creation:	1937
guarantee:	two years	fabrication:	handmade in Autun, France
highlight:	stackable	material:	steel
assembly:	assembled	finition:	available page 300
		use:	outdoor



H 65 Stool, Galvanized

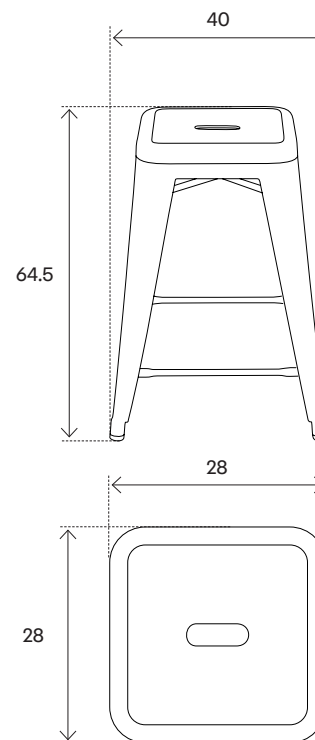

dimensions:	H.65	H.75
width:	40 [CM]	43.5 [CM]
height:	65 [CM]	75 [CM]
depth:	40 [CM]	43.5 [CM]
weight:	4.95 [KG]	5.4 [CM]

H 65 | H 75 STOOL GALVANIZED

designer:	Xavier Pauchard	creation:	1937
guarantee:	two years	fabrication:	handmade in Autun, France
highlight:	stackable	material:	steel
assembly:	assembled	finitions:	galvanized
		use:	outdoor



HPD 75 Stool, Pure White color

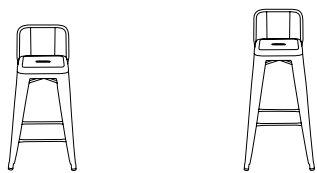
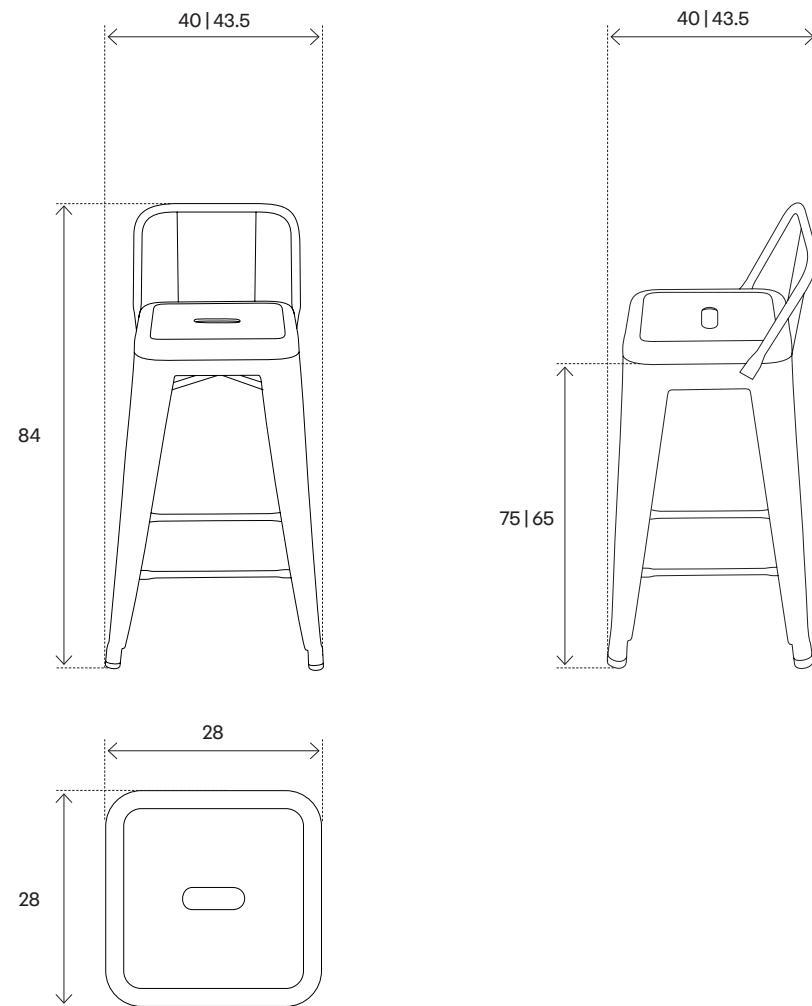

dimensions:	HPD 65	HPD 75
seat height:	65 [CM]	75 [CM]
width:	40 [CM]	43.5 [CM]
height:	84 [CM]	94 [CM]
depth:	40 [CM]	43.5 [CM]
weight:	5.9 [KG]	6.25 [KG]

HPD 65 | HPD 75 INDOOR STOOL

designer:	Studio Tolix	creation:	2007
guarantee:	two years	fabrication:	handmade in Autun, France
highlight:	non-stackable	material:	steel
assembly:	assembled	finition:	available page 300
		use:	indoor



HPD 75 Stool, Raw Steel Varnished

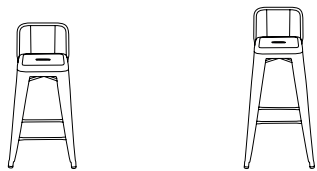
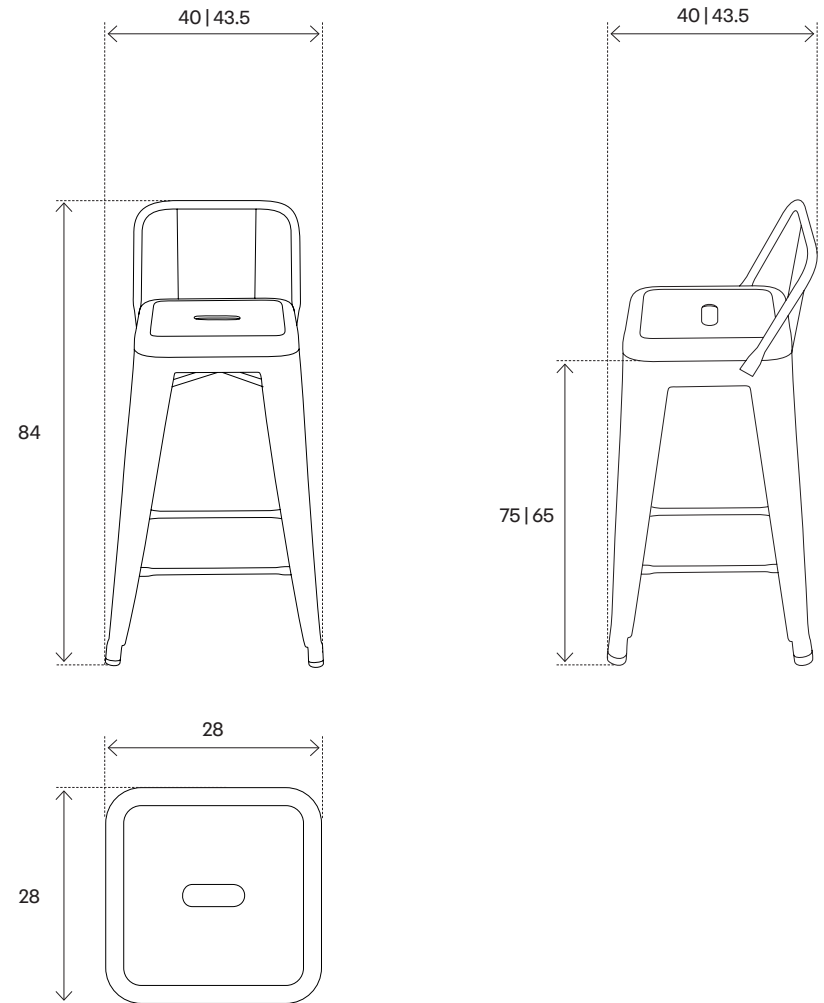

dimensions:	HPD 65	HPD 75
seat height:	65 [CM]	75 [CM]
width:	40 [CM]	43.5 [CM]
height:	84 [CM]	94 [CM]
depth:	40 [CM]	43.5 [CM]
weight:	5.9 [KG]	6.25 [KG]

All the following information is protected by the copyright owned by TOLIX STEEL DESIGN S.A.S.

HPD 65 | HPD 75 INDOOR STOOL VARNISHED

designer:	Studio Tolix	creation:	2007
guarantee:	two years	fabrication:	handmade in Autun, France
highlight:	non-stackable	material:	steel
assembly:	assembled	finition:	varnished raw steel
		use:	indoor

All the following information is protected by the copyright owned by TOLIX STEEL DESIGN S.A.S.



HPD 75 Stool, Pure White color

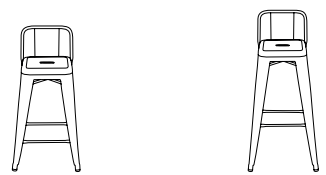
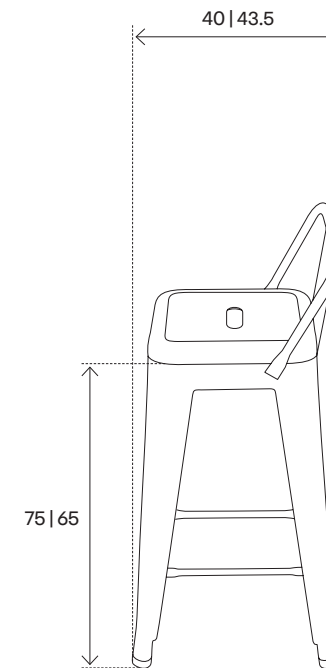
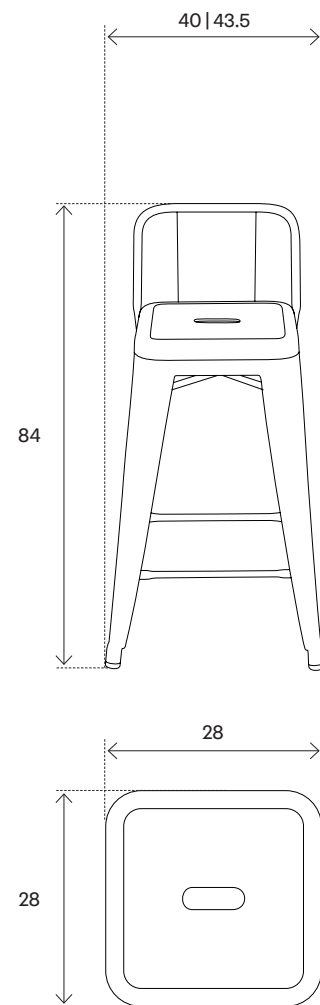

dimensions:	HPD 65	HPD 75
seat height:	65 [CM]	75 [CM]
width:	40 [CM]	43.5 [CM]
height:	84 [CM]	94 [CM]
depth:	40 [CM]	43.5 [CM]
weight:	5.9 [KG]	6.25 [KG]

All the following information is protected by the copyright owned by TOLIX STEEL DESIGN S.A.S.

HPD 65 | HPD 75 OUTDOOR STOOL

designer:	Studio Tolix	creation:	2007
guarantee:	two years	fabrication:	handmade in Autun, France
highlight:	non-stackable	material:	steel
assembly:	assembled	finition:	available page 300
		use:	outdoor

All the following information is protected by the copyright owned by TOLIX STEEL DESIGN S.A.S.



HPD 75 Stool, Galvanized

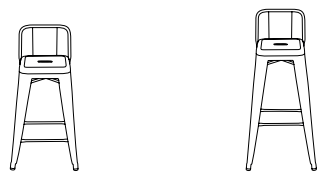
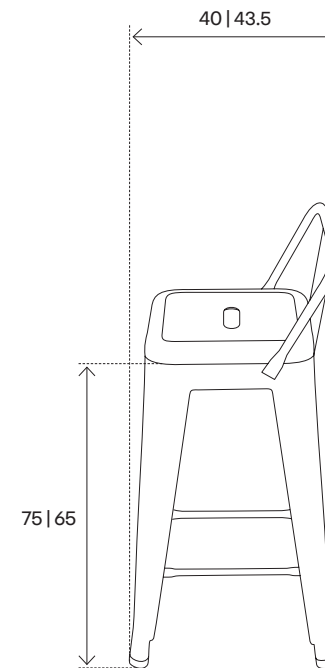
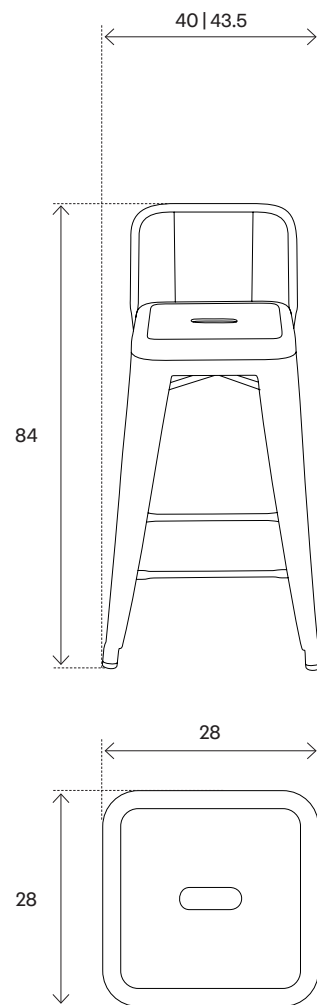

dimensions:	HPD 65	HPD 75
seat height:	65 [CM]	75 [CM]
width:	40 [CM]	43.5 [CM]
height:	84 [CM]	94 [CM]
depth:	40 [CM]	43.5 [CM]
weight:	5.9 [KG]	6.25 [KG]

HPD 65 | HPD 75 STOOL GALVANIZED

designer:	Studio Tolix	creation:	2007
guarantee:	two years	fabrication:	handmade in Autun, France
highlight:	non-stackable	material:	steel
assembly:	assembled	finition:	galvanized
		use:	outdoor

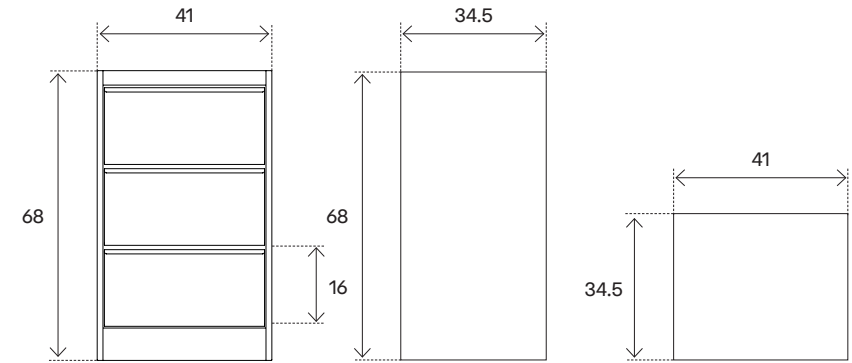
CC3 Filing Cabinet, *Pure White color*

CC3 FILING CABINET

designer:	Xavier Pauchard	creation:	1935
guarantee:	two years	fabrication:	handmade in Autun, France
dimensions ^[OUT] :	W.41 ^[CM] D. 34,5 ^[CM] H.68 ^[CM]	material:	steel
dimensions ^[IN] :	W.38 ^[CM] D.32 ^[CM] H.16×3 ^[CM]	finition:	available page 300
weight:	13.0 ^[KG]	use:	indoor
highlight:	non-stackable	accessories:	removable wheels
assembly:	assemble		



CC3 Filing Cabinet, Raw Steel Varnished

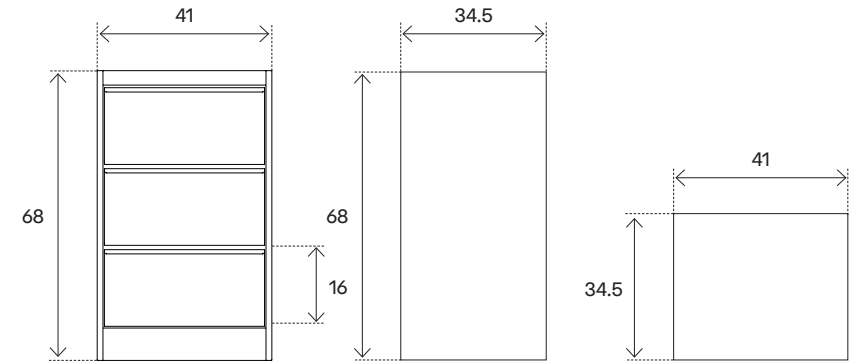

CC3 FILING CABINET VARNISHED

designer:	Xavier Pauchard	creation:	1935
guarantee:	two years	fabrication:	handmade in Autun, France
dimensions ^[OUT] :	W.41 ^[CM] D. 34,5 ^[CM] H.68 ^[CM]	material:	steel
dimensions ^[IN] :	W.38 ^[CM] D.32 ^[CM] H.16×3 ^[CM]	finition:	varnished raw steel
weight:	13.0 ^[KG]	use:	indoor
highlight:	non-stackable	accessories:	removable wheels
assembly:	assemble		

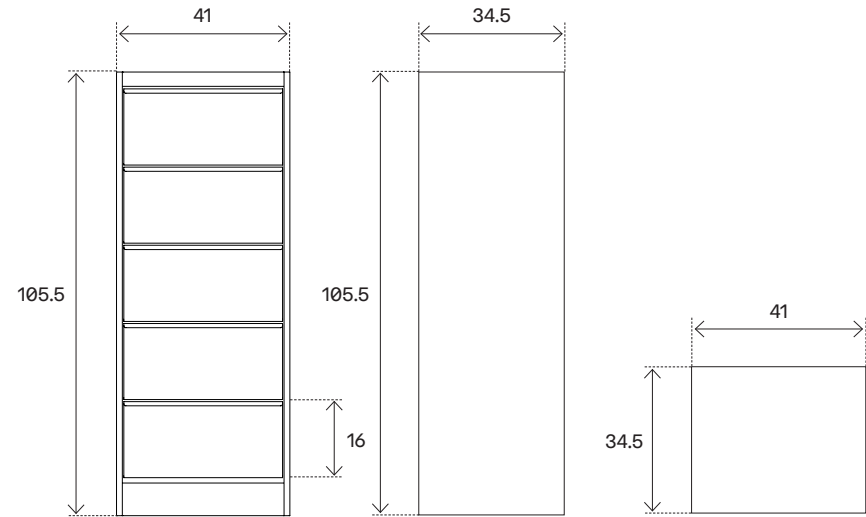

CC5 Filing Cabinet, *Pure White* color

CC5 FILING CABINET

designer:	Xavier Pauchard	creation:	1935
guarantee:	two years	fabrication:	handmade in Autun, France
dimensions ^[OUT] :	W.41 ^[CM] D. 34.5 ^[CM] H.105.5 ^[CM]	material:	steel
dimensions ^[IN] :	W.38 ^[CM] D.32 ^[CM] H.16x5 ^[CM]	finition:	available page 300
weight:	19.0 ^[KG]	use:	indoor
highlight:	non-stackable	assembly:	assembled

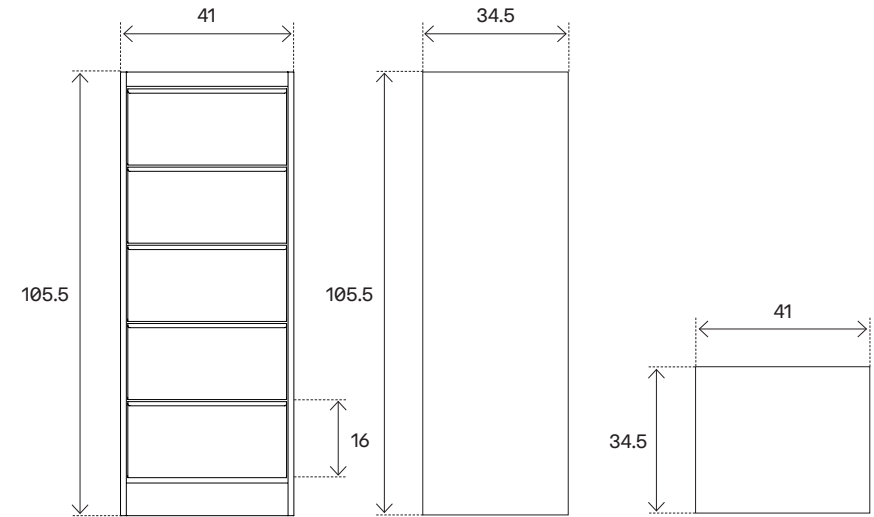
CC5 Filing Cabinet, *Raw Steel Varnished*

CC5 FILING CABINET VARNISHED

designer:	Xavier Pauchard	creation:	1935
guarantee:	two years	fabrication:	handmade in Autun, France
dimensions ^[OUT] :	W.41 ^[CM] D. 34.5 ^[CM] H.105.5 ^[CM]	material:	steel
dimensions ^[IN] :	W.38 ^[CM] D.32 ^[CM] H.16×5 ^[CM]	finition:	varnished raw steel
weight:	19.0 ^[KG]	use:	indoor
highlight:	non-stackable	assembly:	assembled

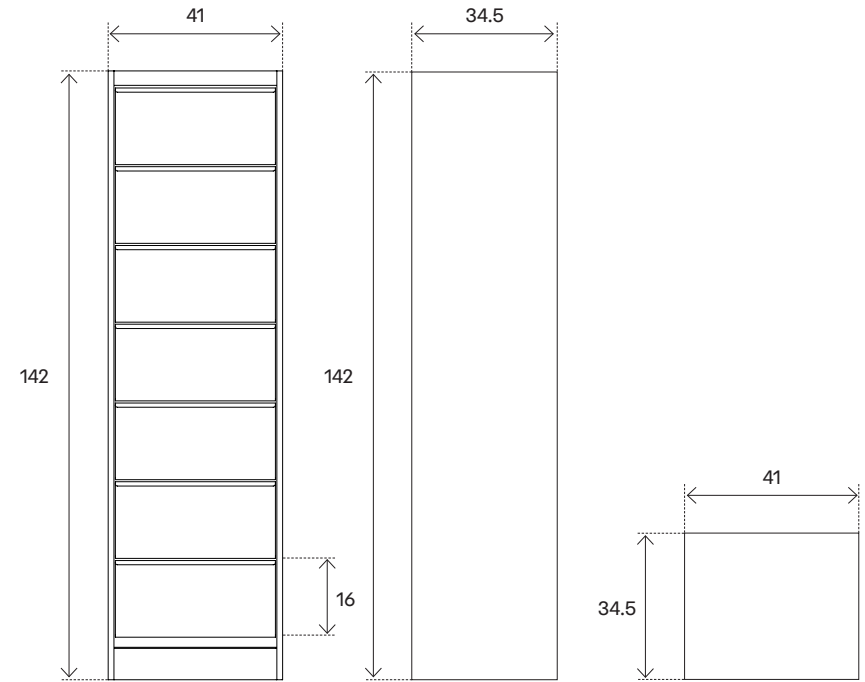

CC7 Filing Cabinet, *Pure White color*

CC7 FILING CABINET

designer:	Xavier Pauchard	creation:	1935
guarantee:	two years	fabrication:	handmade in Autun, France
dimensions ^[OUT] :	W.41 ^[CM] D. 34.5 ^[CM] H.142 ^[CM]	material:	steel
dimensions ^[IN] :	W.38 ^[CM] D.32 ^[CM] H.16x7 ^[CM]	finition:	available page 300
weight:	22.6 ^[KG]	use:	indoor
highlight:	non-stackable	assembly:	assembled



CC7 Filing Cabinet, Raw Steel Varnished

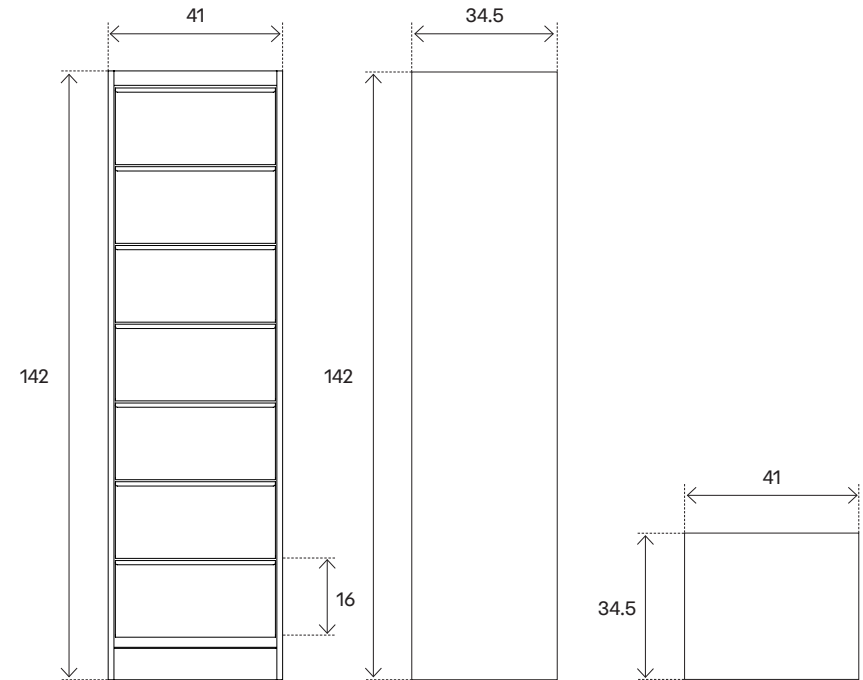

CC7 FILING CABINET VARNISHED

designer:	Xavier Pauchard	creation:	1935
guarantee:	two years	fabrication:	handmade in Autun, France
dimensions ^[OUT] :	W.41 ^[CM] D. 34.5 ^[CM] H.142 ^[CM]	material:	steel
dimensions ^[IN] :	W.38 ^[CM] D.32 ^[CM] H.16×7 ^[CM]	finition:	varnished raw steel
weight:	22.6 ^[KG]	use:	indoor
highlight:	non-stackable	assembly:	assembled

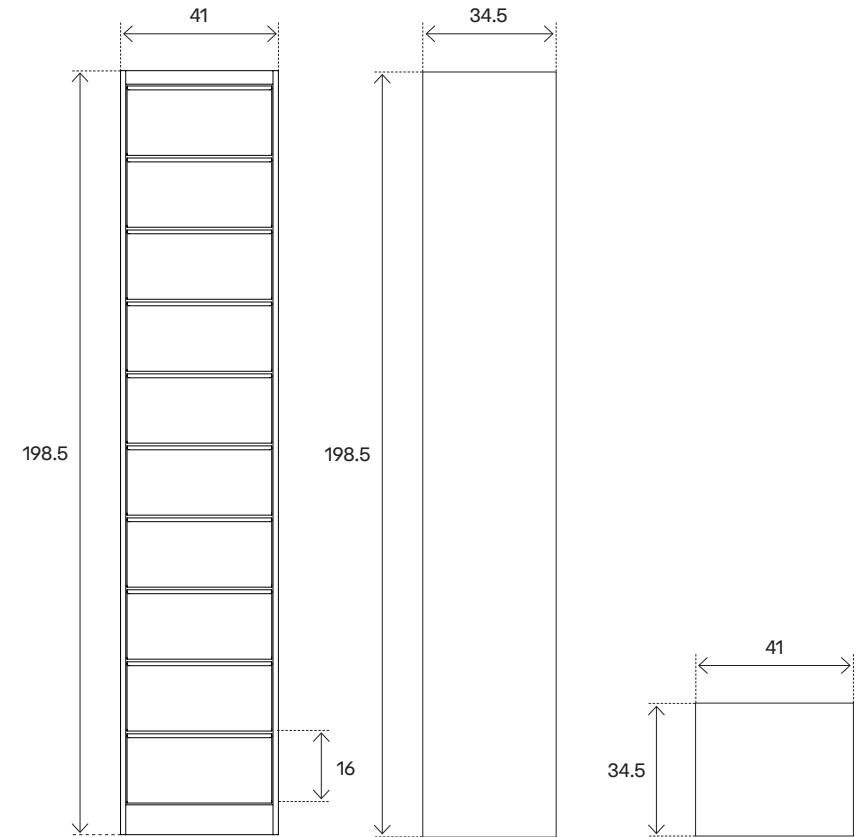
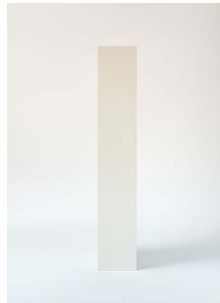
CC10 Filing Cabinet, *Pure White color*

CC10 FILING CABINET

designer:	Xavier Pauchard	creation:	1935
guarantee:	two years	fabrication:	handmade in Autun, France
dimensions ^[OUT] :	W.41 ^[CM] D. 34.5 ^[CM] H.198.5 ^[CM]	material:	steel
dimensions ^[IN] :	W.38 ^[CM] D.32 ^[CM] H.16×10 ^[CM]	finition:	available page 300
weight:	31.0 ^[KG]	use:	indoor
highlight:	non-stackable	assembly:	assembled

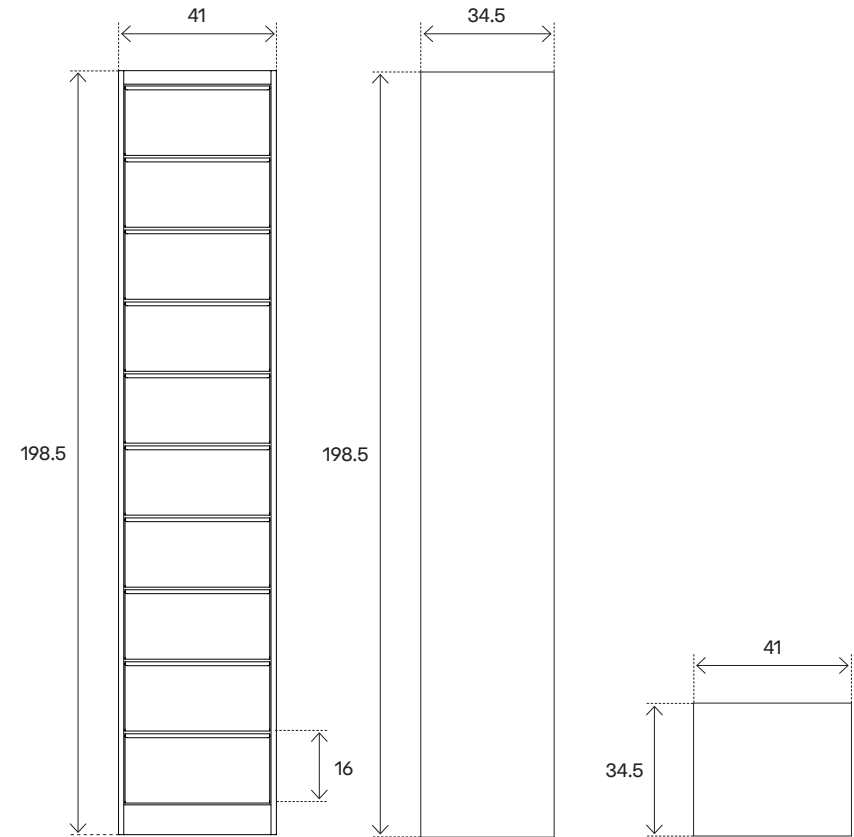
CC10 Filing Cabinet, *Raw Steel Varnished*

CC10 FILING CABINET VARNISHED

designer:	Xavier Pauchard	creation:	1935
guarantee:	two years	fabrication:	handmade in Autun, France
dimensions ^[OUT] :	W.41 ^[CM] D. 34.5 ^[CM] H.198.5 ^[CM]	material:	steel
dimensions ^[IN] :	W.38 ^[CM] D.32 ^[CM] H.16×10 ^[CM]	finition:	varnished raw steel
weight:	31.0 ^[KG]	use:	indoor
highlight:	non-stackable	assembly:	assembled



B1 Locker Storage, Pure White color

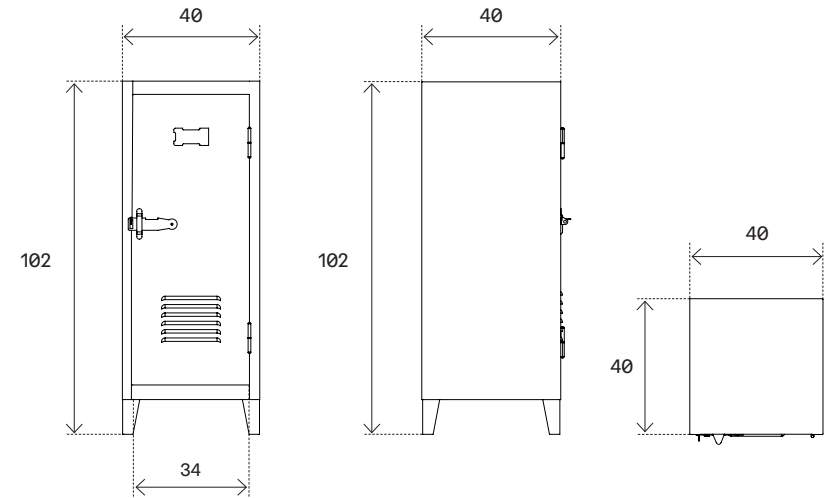

B1 LOCKER STORAGE

designer:	Studio Tolix	creation:	2008
guarantee:	two years	fabrication:	handmade in Autun, France
dimensions ^[OUT] :	W.40 ^[CM] D.40 ^[CM] H.102 ^[CM]	material:	steel
dimensions ^[IN] :	W.34 ^[CM] D.37,5 ^[CM] H.83,3 ^[CM]	finition:	available page 300
weight:	21.0 ^[KG]	use:	indoor
highlight:	non-stackable	accessories:	2 small modular shelves*
assembly:	to assemble		

*shelves can be added in sets of x2 or x4

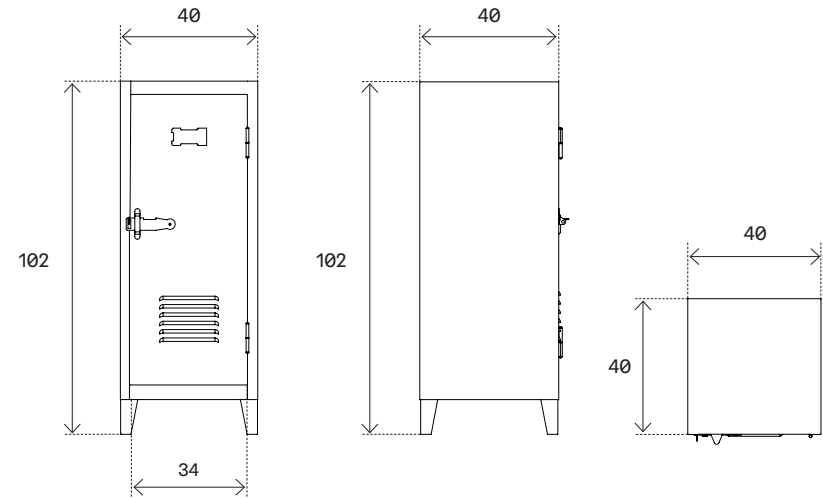
B1 Locker Storage, *Raw Steel Varnished*

B1 LOCKER STORAGE VARNISHED

designer:	Studio Tolix	creation:	2008
guarantee:	two years	fabrication:	handmade in Autun, France
dimensions ^[OUT] :	W.40 ^[CM] D.40 ^[CM] H.102 ^[CM]	material:	steel
dimensions ^[INN] :	W.34 ^[CM] D.37,5 ^[CM] H.83,3 ^[CM]	finition:	varnished raw steel
weight:	21,0 ^[KG]	use:	indoor
highlight:	non-stackable	accessories:	2 small modular shelves*
assembly:	to assemble		

*shelves can be added in sets of x2 or x4



B2 Locker Storage, Pure White color

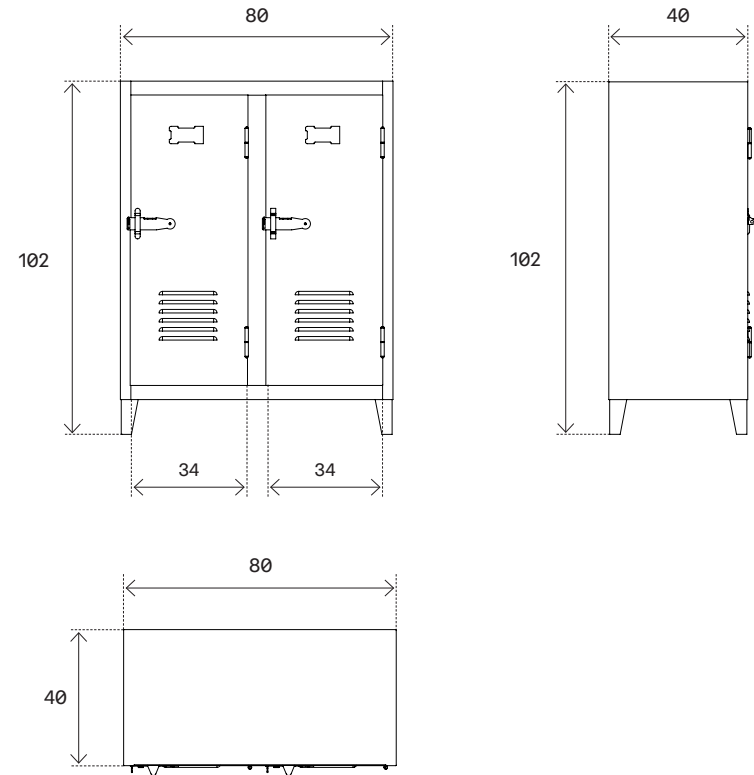

B2 LOCKER STORAGE

designer:	Studio Tolix	creation:	2008
guarantee:	two years	fabrication:	handmade in Autun, France
dimensions ^[OUT] :	W.80 [CM] D.40 [CM] H.102 [CM]	material:	steel
dimensions ^[INN] :	W.34x2 [CM] D.37.5 [CM] H.83.3 [CM]	finition:	available page 300
weight:	32.0 [KG]	use:	indoor
highlight:	non-stackable	accessories:	2 modular shelves*
assembly:	to assemble		

*shelves can be added in sets of x2 or x4



B2 Locker Storage, Raw Steel Varnished

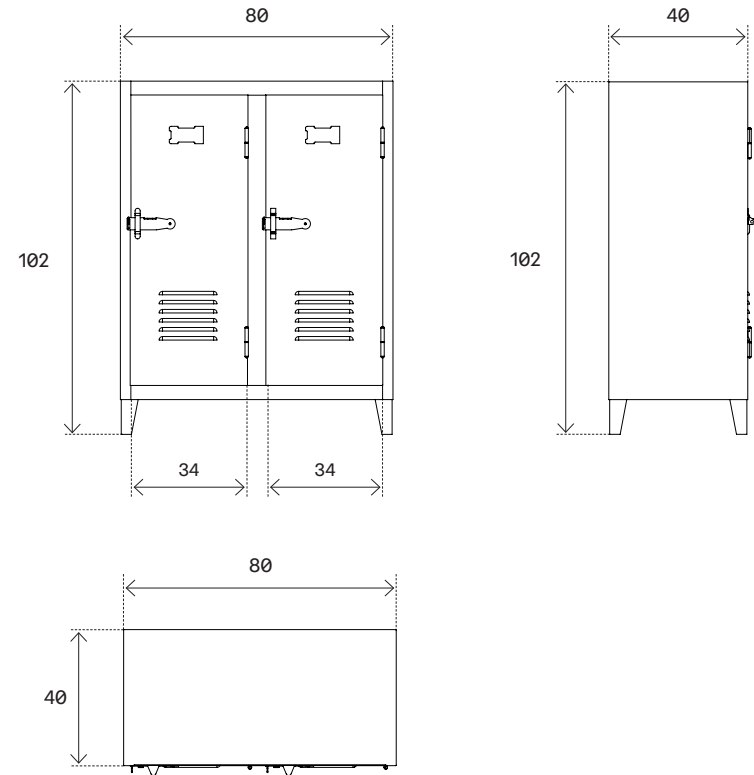

B2 LOCKER STORAGE VARNISHED

designer:	Studio Tolix	creation:	2008
guarantee:	two years	fabrication:	handmade in Autun, France
dimensions ^[OUT] :	W.80 ^[CM] D.40 ^[CM] H.102 ^[CM]	material:	steel
dimensions ^[INN] :	W.34×2 ^[CM] D.37.5 ^[CM] H.83.3 ^[CM]	finition:	varnished raw steel
weight:	32.0 ^[KG]	use:	indoor
highlight:	non-stackable	accessories:	2 modular shelves*
assembly:	to assemble		

*shelves can be added in sets of x2 or x4



B3 Locker Storage, Pure White color

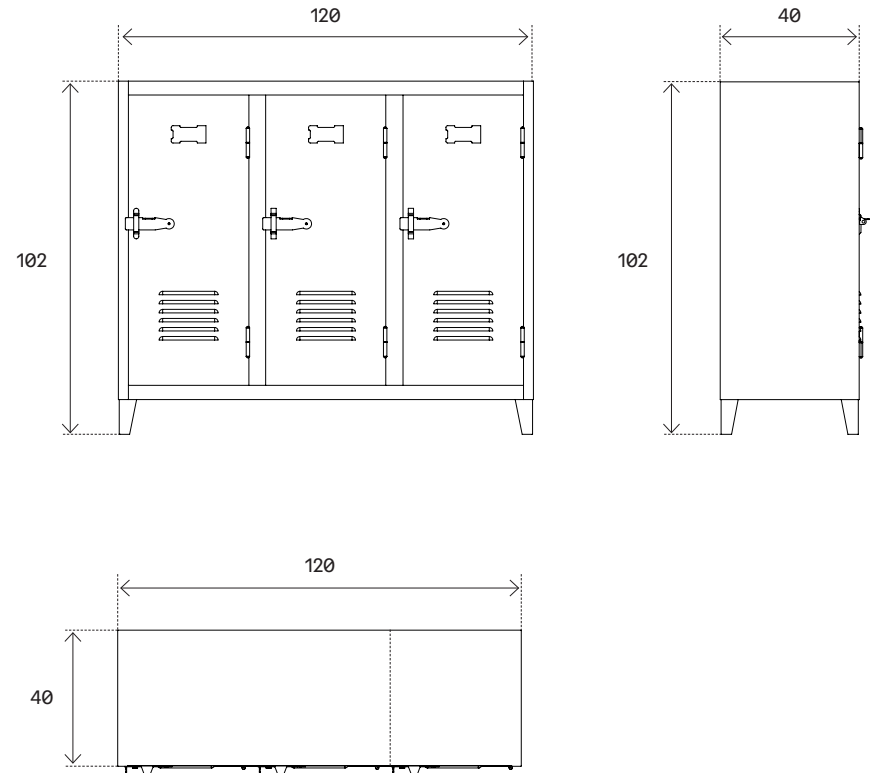

B3 LOCKER STORAGE

designer:	Studio Tolix	creation:	2008
guarantee:	two years	fabrication:	handmade in Autun, France
dimensions ^[OUT] :	W.120 [CM] D.40 [CM] H.102 [CM]	material:	steel
dimensions ^[INN] :	W.34x3 [CM] D.37.5 [CM] H.83.3 [CM]	finition:	available page 300
weight:	50.0 [KGS]	use:	indoor
highlight:	non-stackable	accessories:	2 small and 2 large modular shelves*
assembly:	to assemble		

*shelves can be added in sets of x2 or x4



B3 Locker Storage, Raw Steel Varnished

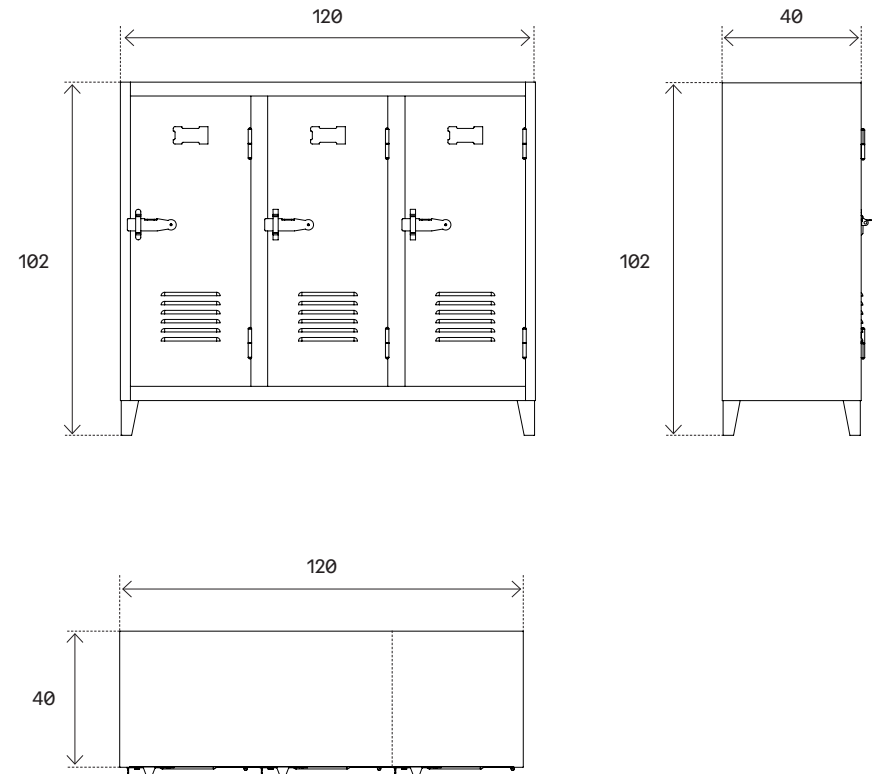

B3 LOCKER STORAGE

designer:	Studio Tolix	creation:	2008
guarantee:	two years	fabrication:	handmade in Autun, France
dimensions ^[OUT] :	W.120 [CM] D.40 [CM] H.102 [CM]	material:	steel
dimensions ^[INN] :	W.34x3 [CM] D.37.5 [CM] H.83.3 [CM]	finition:	varnished raw steel
weight:	50.0 [KGS]	use:	indoor
highlight:	non-stackable	accessories:	2 small and 2 large modular shelves*
assembly:	to assemble		

*shelves can be added in sets of x2 or x4

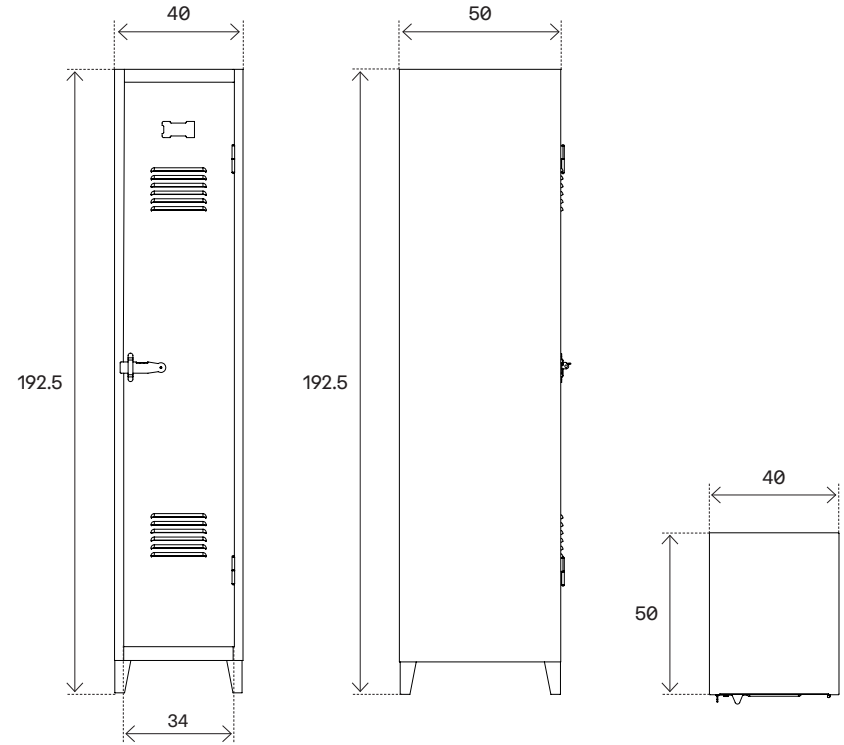

B1 Locker Wardrobe, *Pure White color*

B1 LOCKER WARDROBE

designer:	Xavier Pauchard	creation:	1935
guarantee:	two years	fabrication:	handmade in Autun, France
dimensions [EXT]:	W.40 [CM] D.50 [CM] H.192.5 [CM]	material:	steel
dimensions [INT]:	W.34 [CM] D.47,5 [CM] H.174.3 [CM]	finition:	available page 300
weight:	30.0 [KG]	use:	indoor
highlight:	non-stackable	accessories:	1 modular shelf wardrobe*
assembly:	to assemble		

*shelves can be added in sets of x2 or x4

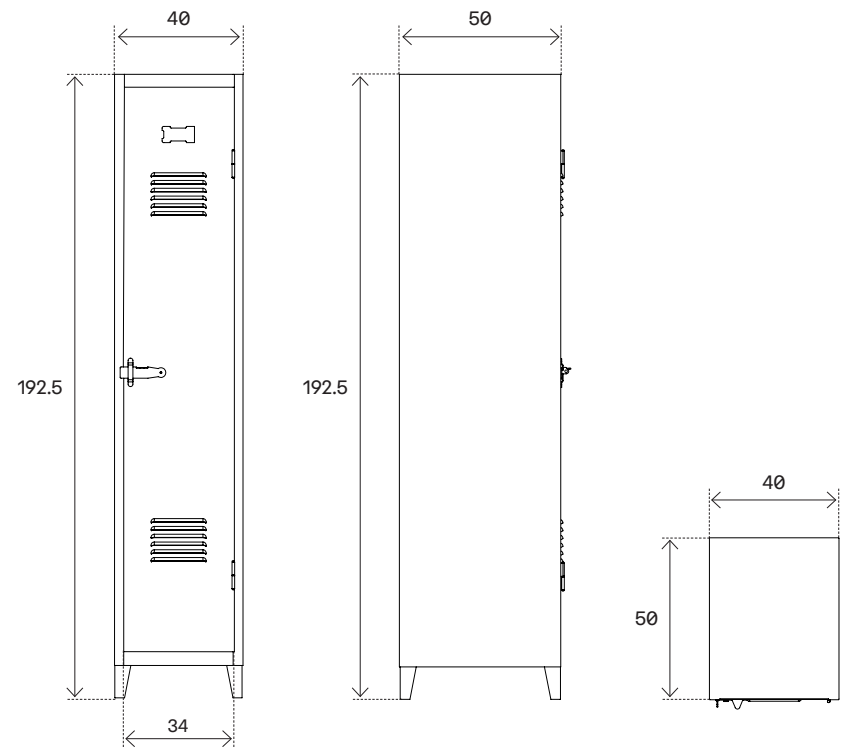
B1 Locker Wardrobe, *Raw Steel Varnished*

B1 LOCKER WARDROBE VARNISHED

designer:	Xavier Pauchard	creation:	1935
guarantee:	two years	fabrication:	handmade in Autun, France
dimensions [EXT]:	W.40 [CM] D.50 [CM] H.192.5 [CM]	material:	steel
dimensions [INT]:	W.34 [CM] D.47,5 [CM] H.174.3 [CM]	finition:	varnished raw steel
weight:	30.0 [KG]	use:	indoor
highlight:	non-stackable	accessories:	1 modular shelf wardrobe*
assembly:	to assemble		

*shelves can be added in sets of x2 or x4



B2 Locker Wardrobe, Pure White color

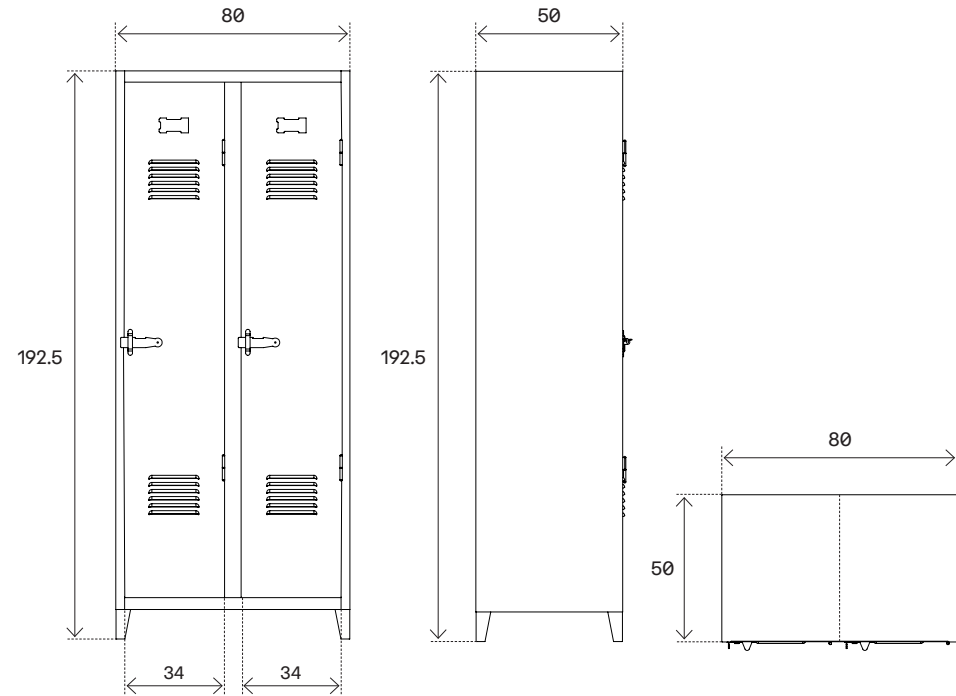

B2 LOCKER WARDROBE

designer:	Xavier Pauchard	creation:	1935
guarantee:	two years	fabrication:	handmade in Autun, France
dimensions [EXT]:	W.80 [CM] D.50 [CM] H.192.5 [CM]	material:	steel
dimensions [INT]:	W.34x2 [CM] D.47.5 [CM] H.174.3 [CM]	finition:	available page 300
weight:	60.0 [KG]	use:	indoor
highlight:	non-stackable	accessories:	2 modular shelves wardrobe*
assembly:	to assemble		

*shelves can be added in sets of x2 or x4

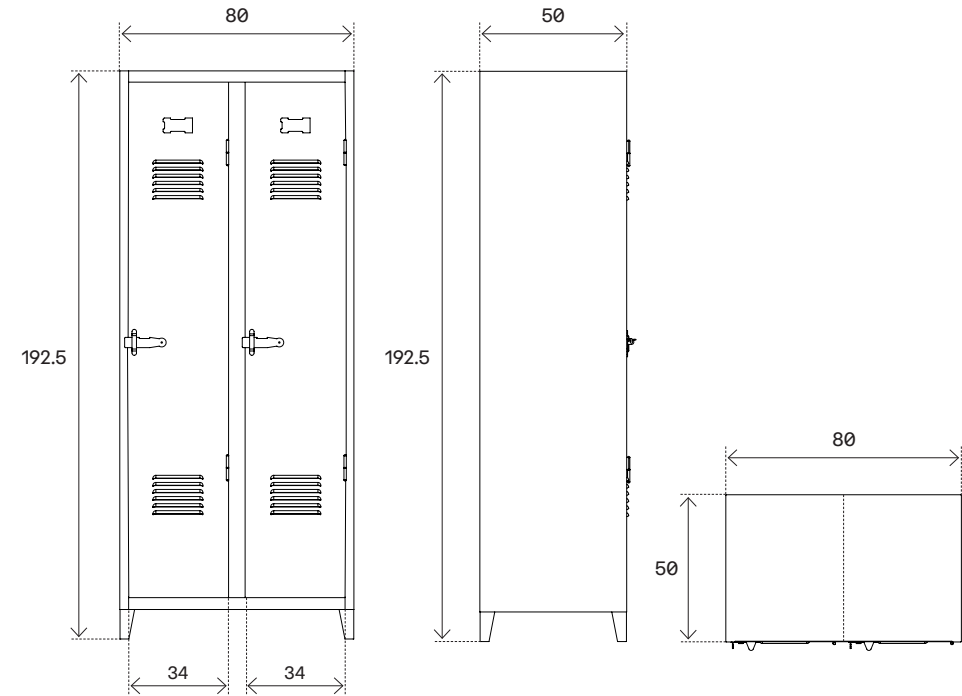
B2 Locker Wardrobe, *Raw Steel Varnished*

B2 LOCKER WARDROBE VARNISHED

designer:	Xavier Pauchard	creation:	1935
guarantee:	two years	fabrication:	handmade in Autun, France
dimensions [EXT]:	W.80 [CM] D.50 [CM] H.192.5 [CM]	material:	steel
dimensions [INT]:	W.34x2 [CM] D.47.5 [CM] H.174.3 [CM]	finition:	raw steel varnished
weight:	60.0 [KG]	use:	indoor
highlight:	non-stackable	accessories:	2 modular shelves wardrobe*
assembly:	to assemble		

*shelves can be added in sets of x2 or x4



TV Stand Perforated, Pure White color

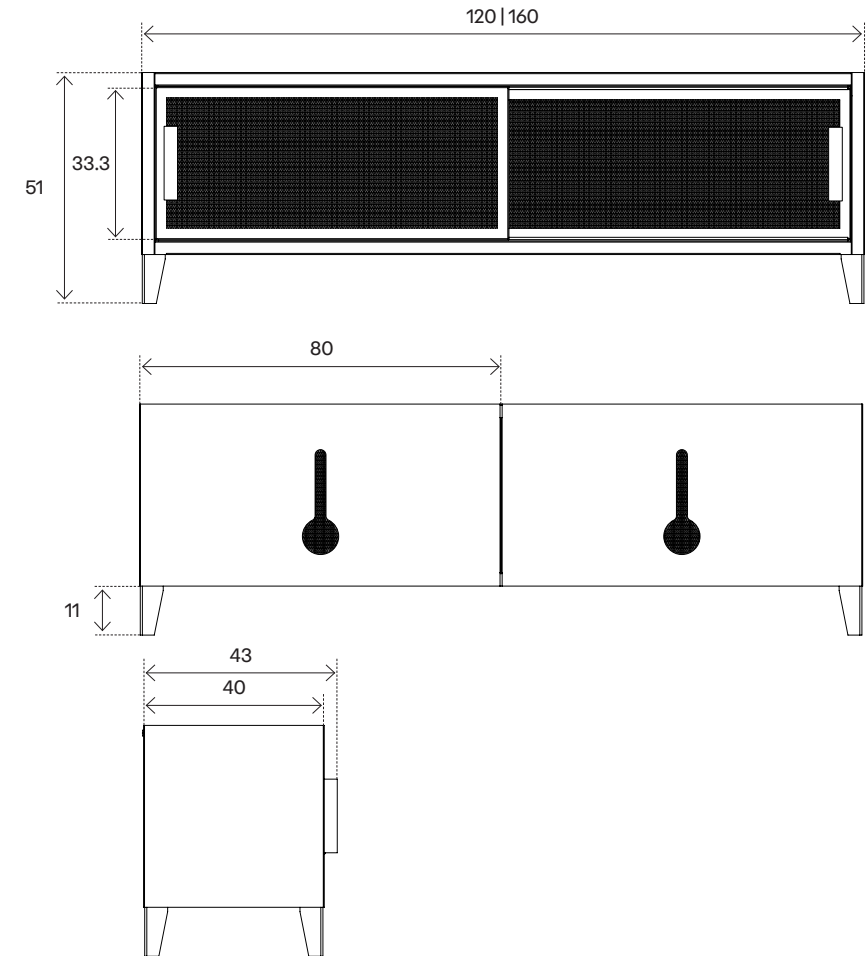

TV STAND PERFORATED

designer:	Studio Tolix	creation:	2021
guarantee:	two years	fabrication:	handmade in Autun, France
dimensions ^[A] :	120 [CM] 51 [CM]	material:	steel
dimensions ^[B] :	160 [CM] 51 [CM]	finition:	available page 300
weight:	32.9 [KG] 42.2 [KG]	use:	indoor
highlight:	non-stackable	assembly:	to assemble

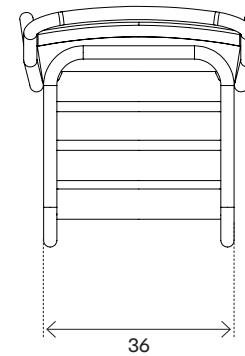
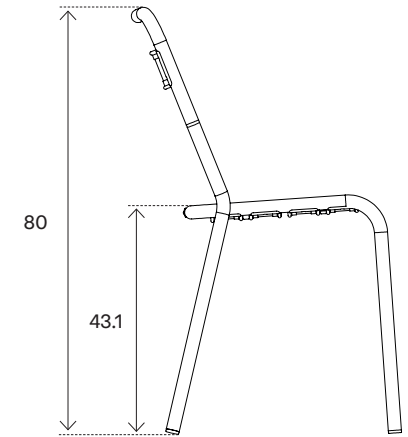
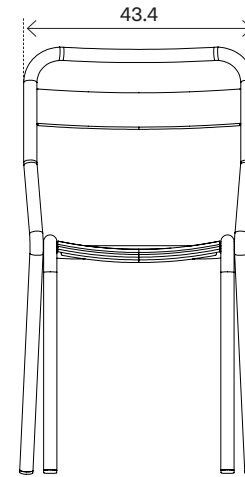
B4 Chair, *Pure White color*

B4 CHAIR OUTDOOR

designer:	Jean Pauchard	creation:	
guarantee:	two years	fabrication:	handmade in Autun, France
dimensions:	W.43.4 [CM] D.45 [CM] H.80 [CM]	material:	steel
seat:	W.36 [CM] D.38 [CM] H.43 [CM]	finition:	available page 300
weight:	4.41 [KG]	use:	outdoor
highlight:	stackable up to 4 units	assembly:	assembled



B4 Chair, Galvanized

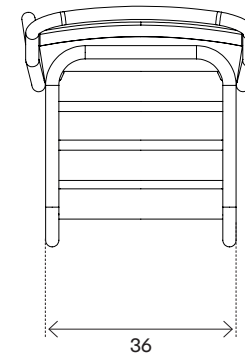
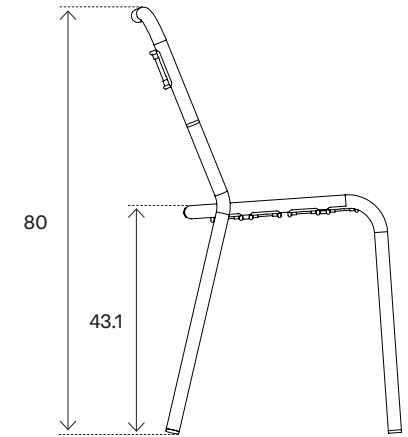
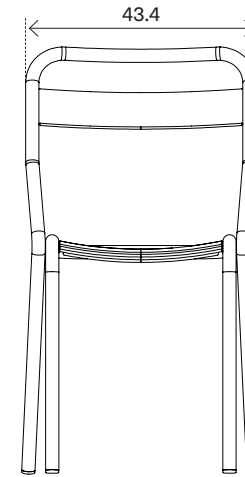

B4 CHAIR GALVANIZED

designer:	Jean Pauchard	creation:	
guarantee:	two years	fabrication:	handmade in Autun, France
dimensions:	W.43.4 [CM] D.45 [CM] H.80 [CM]	material:	steel
seat:	W.36 [CM] D.38 [CM] H.43 [CM]	finition:	galvanized
weight:	5.45 [KG]	use:	outdoor
highlight:	stackable up to 4 units	assembly:	assembled



B5 Chair, *Pure White color*

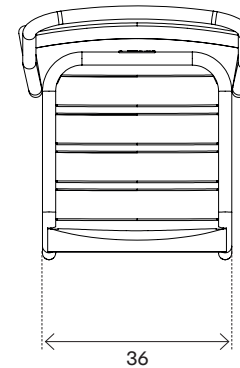
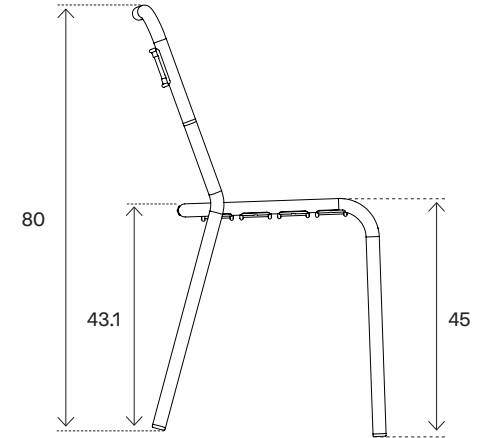
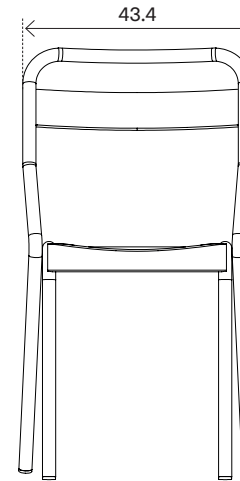

B5 CHAIR OUTDOOR

designer:	Jean Pauchard	creation:	
guarantee:	two years	fabrication:	handmade in Autun, France
dimensions:	W.43.4 [CM] D.45 [CM] H.80 [CM]	material:	steel
seat:	W.36 [CM] D.38 [CM] H.43 [CM]	finition:	available page 300
weight:	4.64 [KG]	use:	outdoor
highlight:	stackable up to 4 units	assembly:	assembled



B5 Chair, Galvanized

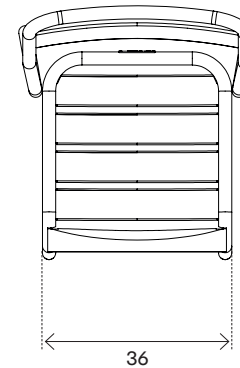
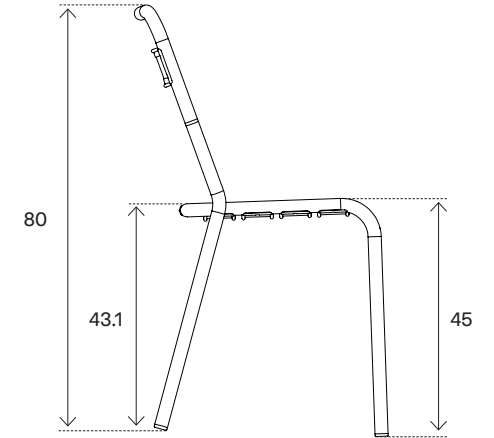
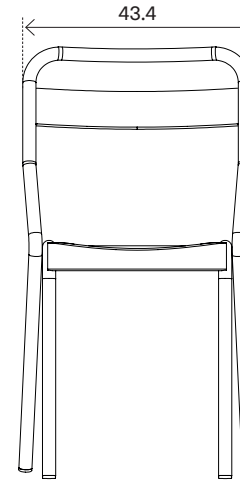

B5 CHAIR GALVANIZED

designer:	Jean Pauchard	creation:	
guarantee:	two years	fabrication:	handmade in Autun, France
dimensions:	W.43.4 [CM] D.45 [CM] H.80 [CM]	material:	steel
seat:	W.36 [CM] D.38 [CM] H.43 [CM]	finition:	galvanized
weight:	4.64 [KG]	use:	outdoor
highlight:	stackable up to 4 units	assembly:	assembled

T55/56. COLLECTION

[ed. 2024]

La collection T55/56 est le fruit d'une relève assurée avec courage et audace par le fils de Xavier Pauchard: Jean.

T55/56 est le résultat d'un juste équilibre entre la perpétuation du savoir-faire Tolix et la volonté de renouveau en accordance avec le style résolument avant-gardiste des années 50-60.

Design singulier, lignes fuselées, pieds fins caractérisent cette collection composée d'un fauteuil et d'une table plateau acier ou bois.^[FR]

The T55/56 collection is the result of a succession courageously and boldly ensured by Xavier Pauchard's son, Jean.

T55/56 represents a careful balance between perpetuating Tolix's craftsmanship and a desire for renewal in accordance with the decidedly *avant-garde style* of the 1950s–1960s.

Unique design, svelte shape, and slender base characterize this collection composed of a chair and a table with a steel or wood top.^[EN]





A56 Armchair, *Pure White color*

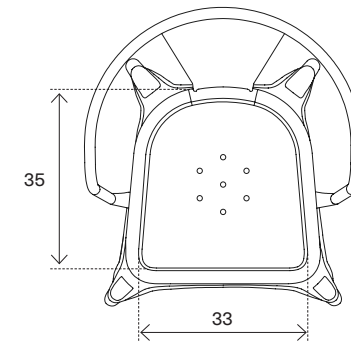
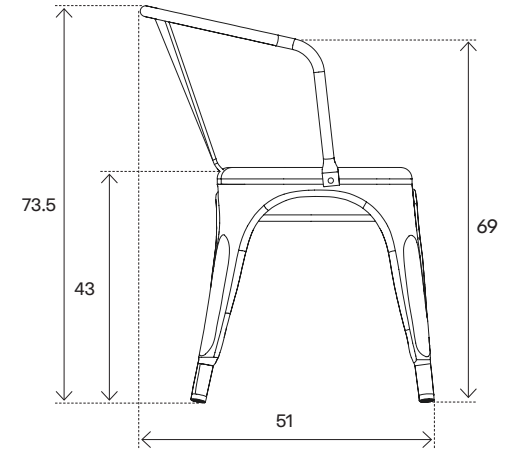
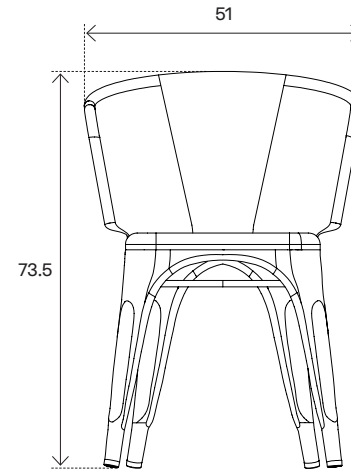

A56 ARMCHAIR

designer:	Jean Pauchard	creation:	1956
guarantee:	two years	fabrication:	handmade in Autun, France
dimensions:	W.51 ^[CM] D.51 ^[CM] H.73.5 ^[CM]	material:	steel
seat:	W.33 ^[CM] D.35 ^[CM] H.43 ^[CM]	finition:	available page 300
armrests:	H.69 ^[CM]	use:	indoor
weight:	4.5 ^[KG]	assembly:	assembled
highlight:	stackable up to 8 units		



A56 Armchair, Raw Steel Varnished

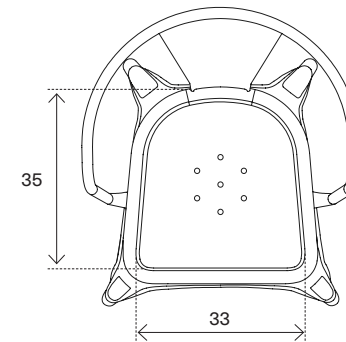
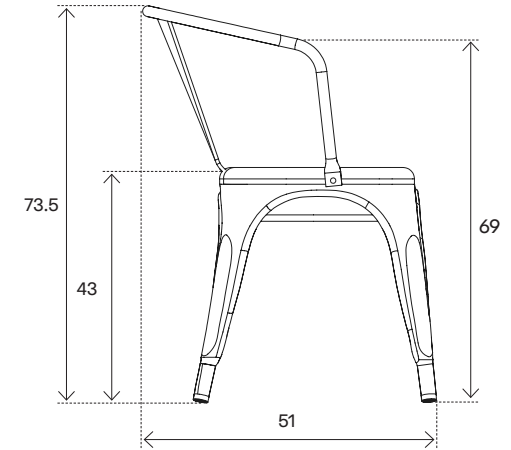
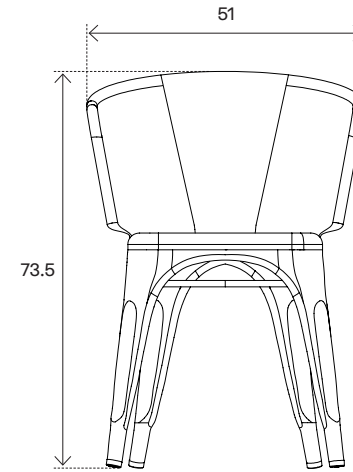

A56 ARMCHAIR VARNISHED

designer:	Jean Pauchard	creation:	1956
guarantee:	two years	fabrication:	handmade in Autun, France
dimensions:	W.51 ^[CM] D.51 ^[CM] H.73.5 ^[CM]	material:	steel
seat:	W.33 ^[CM] D.35 ^[CM] H.43 ^[CM]	finition:	varnished raw steel
armrests:	H.69 ^[CM]	use:	indoor
weight:	4.5 ^[KG]	assembly:	assembled
highlight:	stackable up to 8 units		



A56 Armchair, Galvanized

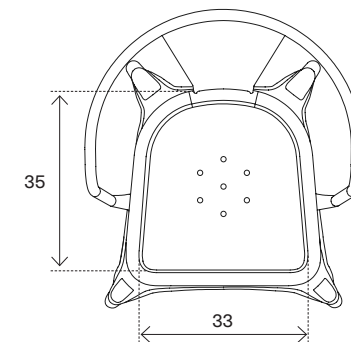
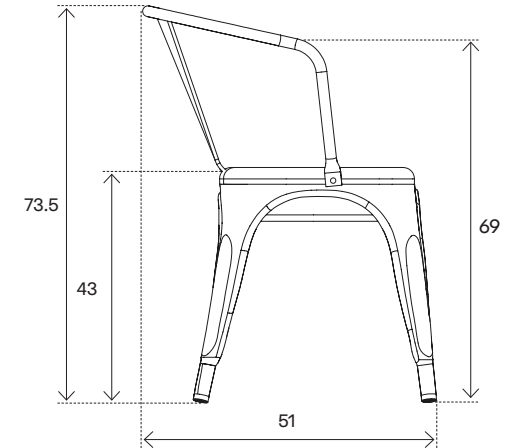
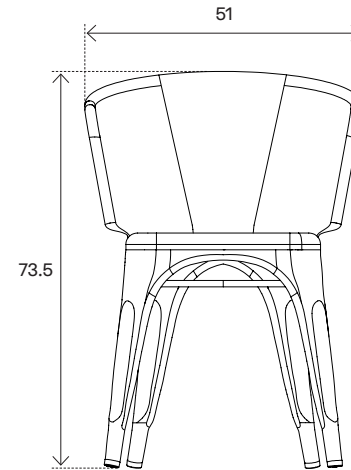

A56 ARMCHAIR GALVANIZED

designer:	Jean Pauchard	creation:	1956
guarantee:	two years	fabrication:	handmade in Autun, France
dimensions:	W.51 ^[CM] D.51 ^[CM] H.73.5 ^[CM]	material:	steel
seat:	W.33 ^[CM] D.35 ^[CM] H.43 ^[CM]	finition:	galvanized
armrests:	H.69 ^[CM]	use:	outdoor
weight:	4.5 ^[KG]	assembly:	assembled
highlight:	stackable up to 8 units		



55 Console, Pure White color

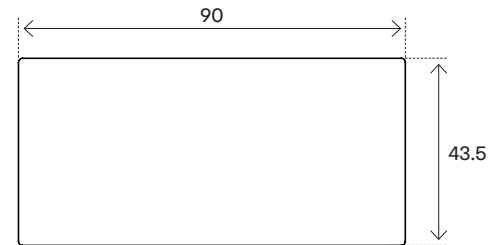
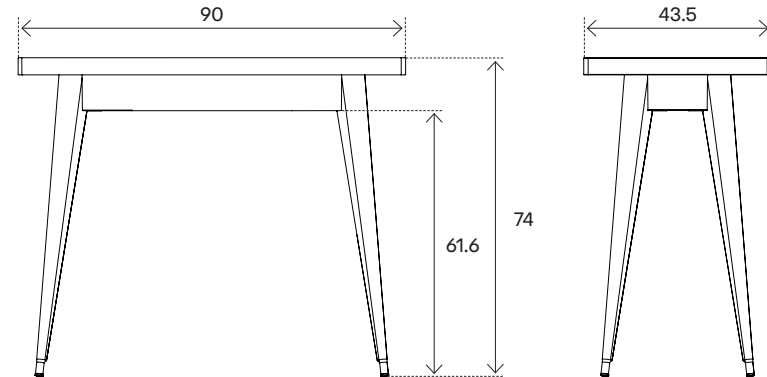

55 CONSOLE

designer:	Jean Pauchard	creation:	1955
guarantee:	two years	fabrication:	handmade in Autun, France
dimensions:	L.90 [CM] W.43,5 [CM] H.74 [CM]	material:	steel
weight:	15,0 [KG]	finition:	available page 300
highlight:	non-stackable	use:	indoor
assembly:	to assemble		



55 Console, Raw Steel Varnished

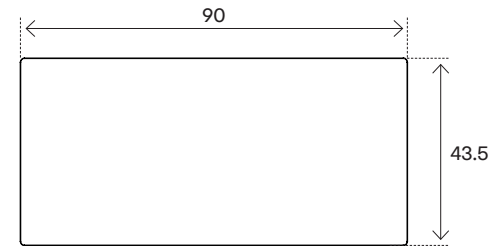
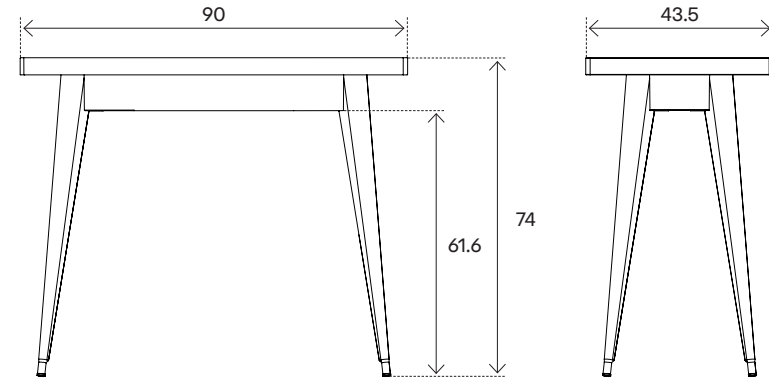

55 CONSOLE VARNISHED

designer:	Jean Pauchard	creation:	1955
guarantee:	two years	fabrication:	handmade in Autun, France
dimensions:	L.90 [CM] W.43,5 [CM] H.74 [CM]	material:	steel
weight:	15,0 [KG]	finition:	varnished raw steel
highlight:	non-stackable	use:	indoor
assembly:	to assemble		



55 Table dimensions [B], Pure White color

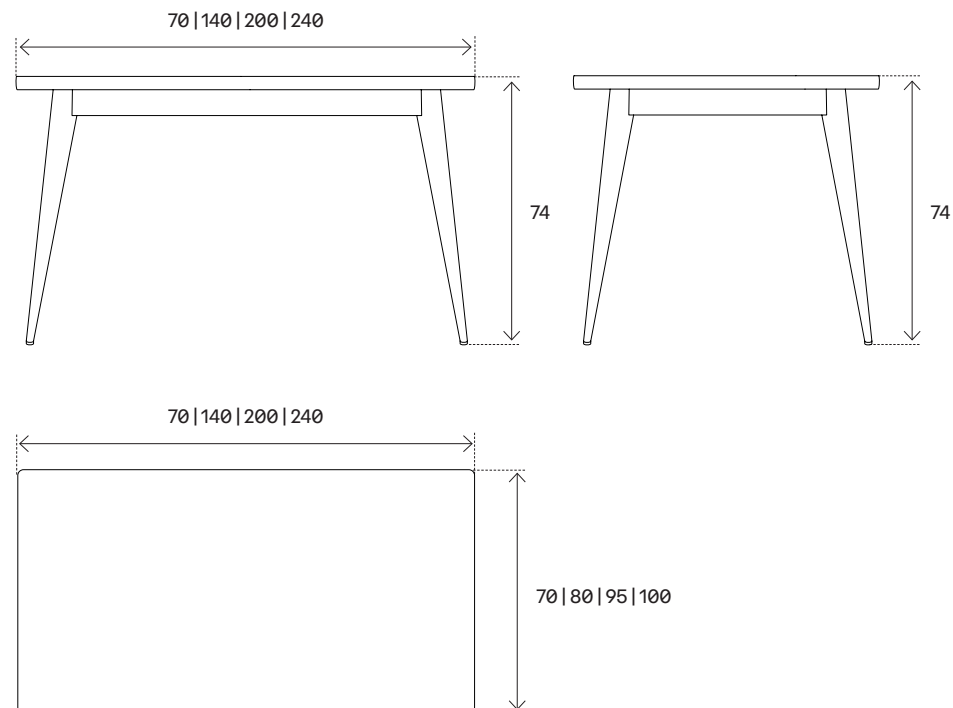

55 TABLE

designer:	Jean Pauchard	creation:	1955
guarantee:	two years	fabrication:	handmade in Autun, France
dimensions* [A]:	L.70 [CM] W.70 [CM] H.74 [CM]	material:	steel
weight:	14.0 [KG]	finition:	available page 300
highlight:	non-stackable	use:	indoor
assembly:	to assemble		

*other dimensions available: [B] 4/6 people L.140 [CM] W.80 [CM] H.74 [CM] | 24,1 [KG]
 [C] 10 people L.200 [CM] W.95 [CM] H.74 [CM] | 37,8 [KG] | [D] 10/12 people L.240 [CM] W.100 [CM] H.74 [CM] | 42,5 [KG]



55 Table dimensions [B], Raw Steel Varnished

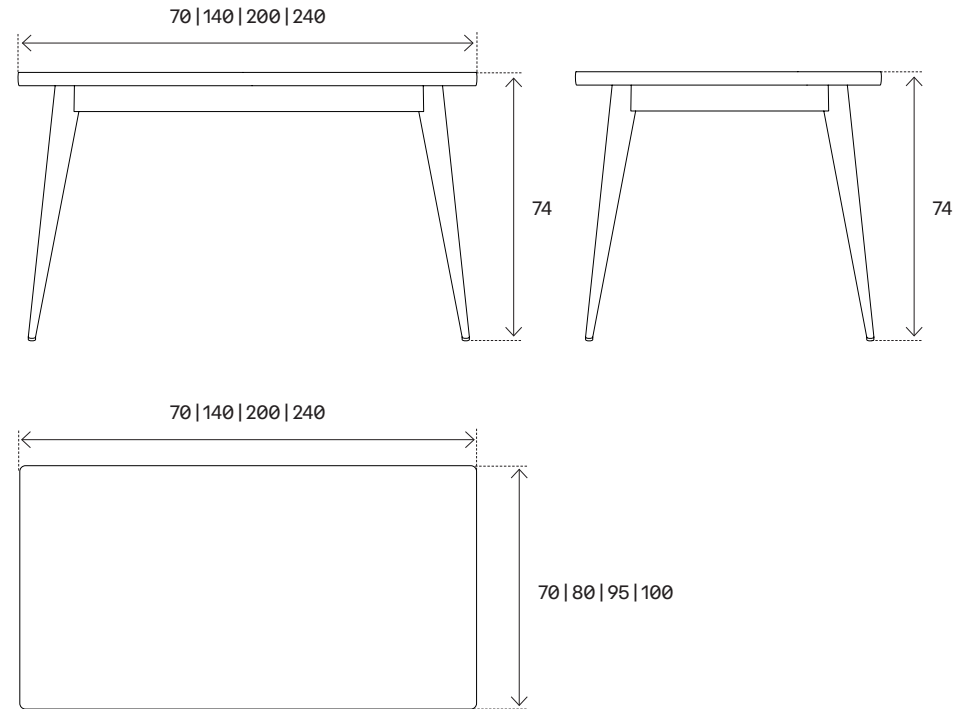

55 TABLE VARNISHED

designer:	Jean Pauchard	creation:	1955
guarantee:	two years	fabrication:	handmade in Autun, France
dimensions* [A]:	L.70 [CM] W.70 [CM] H.74 [CM]	material:	steel
weight:	14.0 [KG]	finition:	varnished raw steel
highlight:	non-stackable	use:	indoor
assembly:	to assemble		

*other dimensions available: [B] 4/6 people L.140 [CM] W.80 [CM] H.74 [CM] | 24,1 [KG]
 [C] 10 people L.200 [CM] W.95 [CM] H.74 [CM] | 37,8 [KG] | [D] 10/12 people L.240 [CM] W.100 [CM] H.74 [CM] | 42,5 [KG]

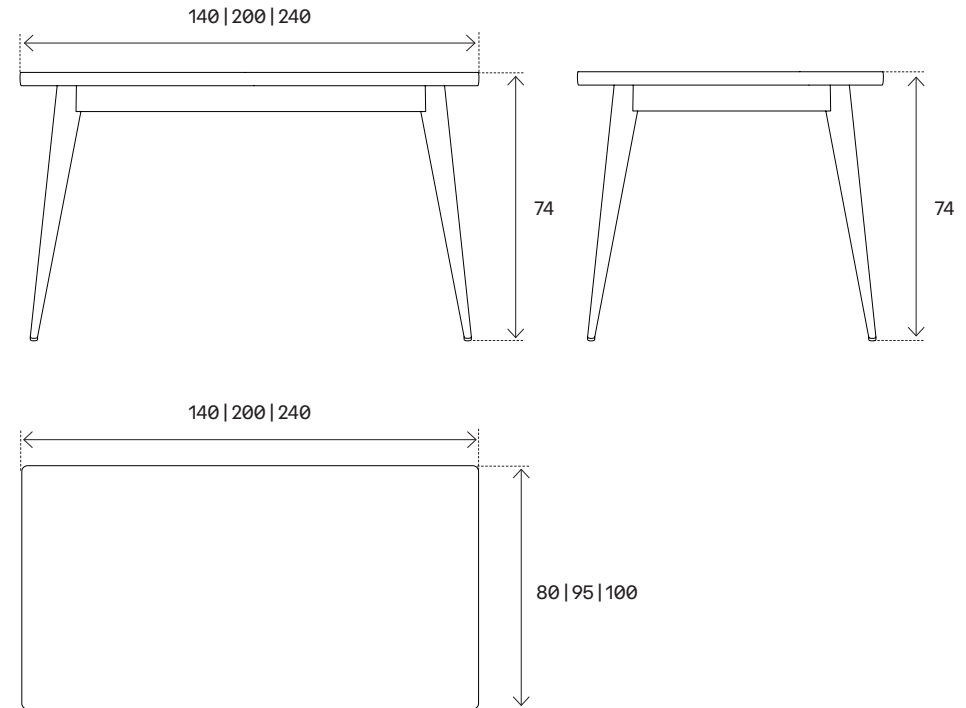

55 Table Wooden Legs dimensions [A], Pure White color

55 TABLE WOODEN LEGS

designer:	Jean Pauchard	creation:	1955
guarantee:	two years	fabrication:	handmade in Autun, France
dimensions* [A]:	L.140 [CM] W.80 [CM] H.74 [CM]	materials:	steel oak
weight:	23,4 [KG]	finition:	available page 300
highlight:	non-stackable	use:	indoor
assembly:	to assemble		

*other dimensions available: [B] 10 people L.200 [CM] W.95 [CM] H.74 [CM] | 39,8 [KG]
 [C] 10/12 people L.240 [CM] W.100 [CM] H.74 [CM] | 41,7 [KG]



55 Table Wooden Legs dimensions [A], Varnished raw steel

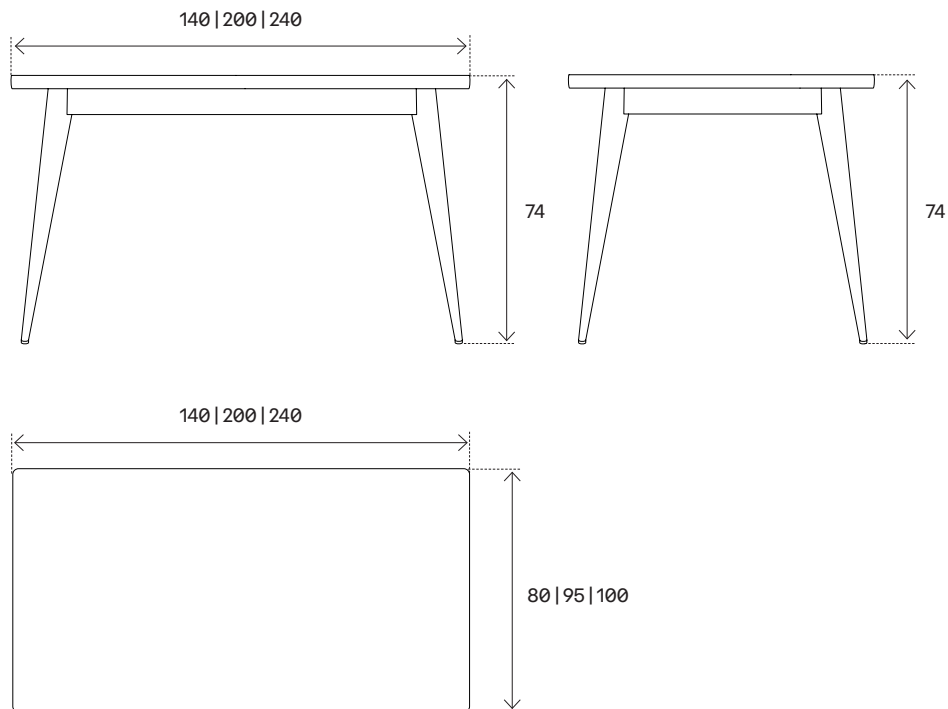

55 TABLE VARNISHED WOODEN LEGS

designer:	Jean Pauchard	creation:	1955
guarantee:	two years	fabrication:	handmade in Autun, France
dimensions* [A]:	L.140 [CM] W.80 [CM] H.74 [CM]	materials:	steel oak
weight:	23,4 [KG]	finition:	varnished raw steel
highlight:	non-stackable	use:	indoor
assembly:	to assemble		

*other dimensions available: [B] 10 people L.200 [CM] W.95 [CM] H.74 [CM] | 39,8 [KG]
 [C] 10/12 people L.240 [CM] W.100 [CM] H.74 [CM] | 41,7 [KG]

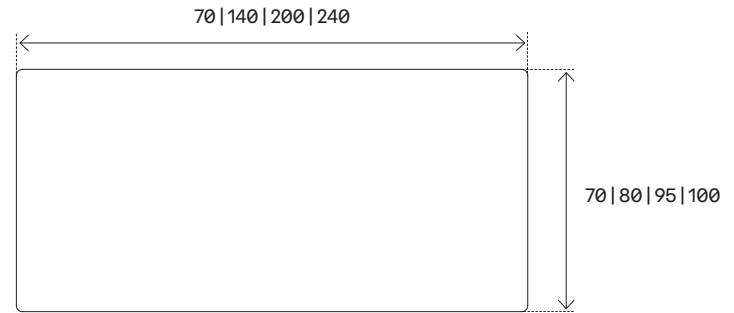
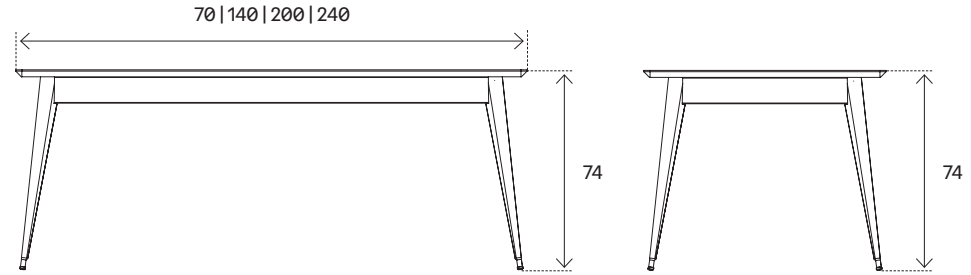

55 Table Oak Table Top dimensions [D], Pure White Color

55 TABLE OAK TABLE TOP

designer:	Jean Pauchard	creation:	1955
guarantee:	two years	fabrication:	handmade in Autun, France
dimensions* [A]:	L.70 [CM] W.70 [CM] H.74 [CM]	materials:	steel oak
weight:	15,1 [KG]	finition:	available page 300
highlight:	non-stackable	use:	indoor
assembly:	to assemble		

*other dimensions available: [B] 4/6 people L.140 [CM] W.80 [CM] H.74 [CM] | 29,7 [KG]
 [C] 10 people L.200 [CM] W.95 [CM] H.74 [CM] | 50,2 [KG] | [D] 10/12 people L.240 [CM] W.100 [CM] H.74 [CM] | 61,4 [KG]



55 Table Oak Table Top dimensions [D], Raw Steel Varnished

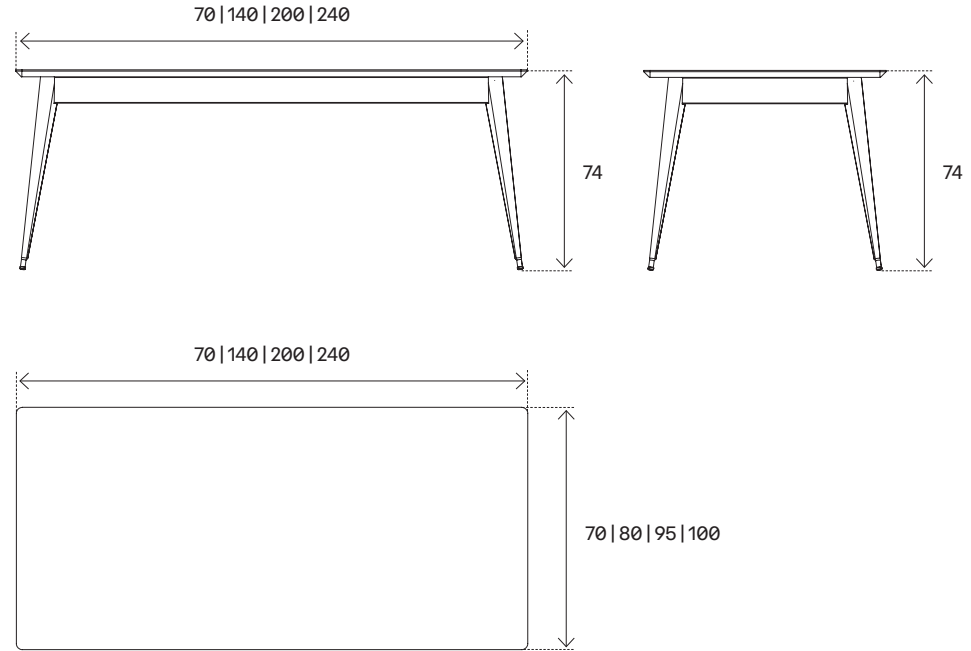

55 TABLE VARNISHED OAK TABLE TOP

designer:	Jean Pauchard	creation:	1955
guarantee:	two years	fabrication:	handmade in Autun, France
dimensions* [A]:	L.70 [CM] W.70 [CM] H.74 [CM]	materials:	steel oak
weight:	15,1 [KG]	finition:	varnished raw steel
highlight:	non-stackable	use:	indoor
assembly:	to assemble		

*other dimensions available: [B] 4/6 people L.140 [CM] W.80 [CM] H.74 [CM] | 29,7 [KG]
 [C] 10 people L.200 [CM] W.95 [CM] H.74 [CM] | 50,2 [KG] | [D] 10/12 people L.240 [CM] W.100 [CM] H.74 [CM] | 61,4 [KG]

M. COLLECTION [ed. 2024]

M comme miniature, comme minutieuse, comme métallique. Mais surtout M comme Mouette, nom charmant donné par Xavier Pauchard à cette collection qu'il a dessiné pour ses propres enfants et afin d'exploiter les chutes de tôle jusqu'alors perdues.

Xavier Pauchard précurseur dans la sobriété et le non-gaspillage. Grâce à la collection M, les enfants prennent place dans l'univers Tolix.^[FR]

M stands for miniature, meticulous, and metallic. But above all, M stands for Mouette (Seagull), a charming name given by Xavier Pauchard to this collection that he designed for his own children and to make use of the metal scraps that were previously wasted.

Xavier Pauchard was a pioneer in simplicity and non-waste. Thanks to the M collection, children find their place in the Tolix universe.^[EN]





Mouette Kids Armchair, Pure White color

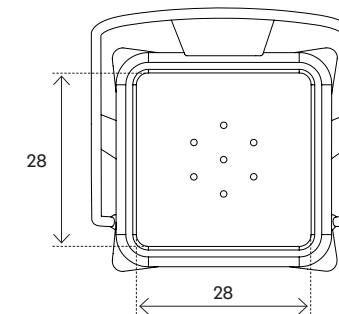
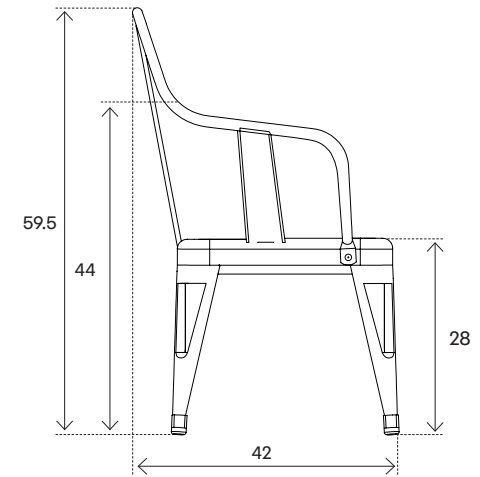
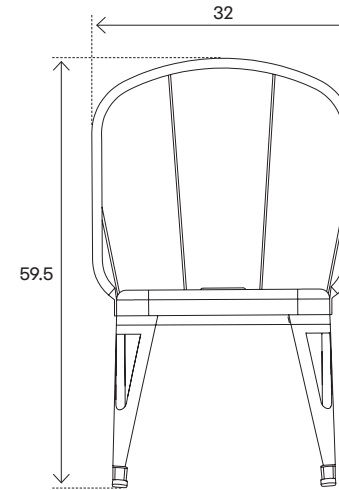

MOUETTE KIDS ARMCHAIR

designer:	Xavier Pauchard	creation:	1935
guarantee:	two years	fabrication:	handmade in Autun, France
dimensions:	W.32 [CM] D.42 [CM] H.59.5 [CM]	material:	steel
seat:	W.28 [CM] D.28 [CM] H.28 [CM]	finition:	available page 300
armrests:	W.25 [CM] H.44 [CM]	use:	indoor
weight:	3,1 [KG]	assembly:	assembled
highlight:	stackable up to 8 units		



Mouette Kids Armchair, Raw Steel Varnished

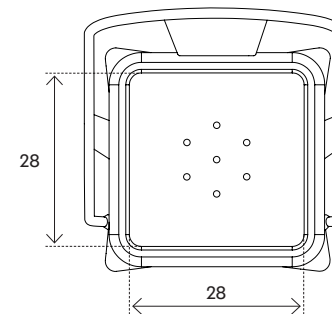
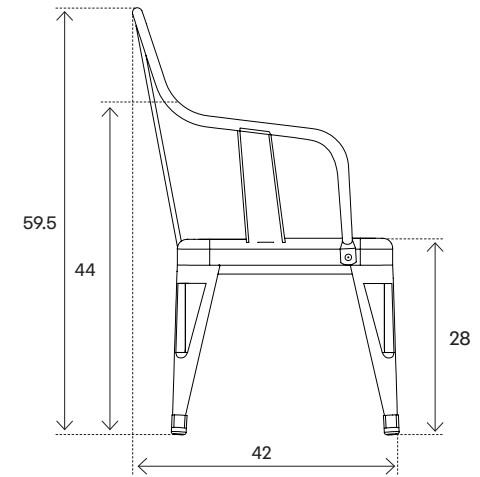
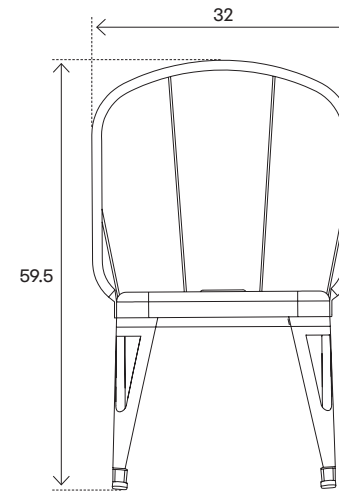

MOUETTE KIDS ARMCHAIR VARNISHED

designer:	Xavier Pauchard	creation:	1935
guarantee:	two years	fabrication:	handmade in Autun, France
dimensions:	W.32 [CM] D.42 [CM] H.59.5 [CM]	material:	steel
seat:	W.28 [CM] D.28 [CM] H.28 [CM]	finition:	varnished raw steel
armrests:	W.25 [CM] H.44 [CM]	use:	indoor
weight:	3.1 [KG]	assembly:	assembled
highlight:	stackable up to 8 units		

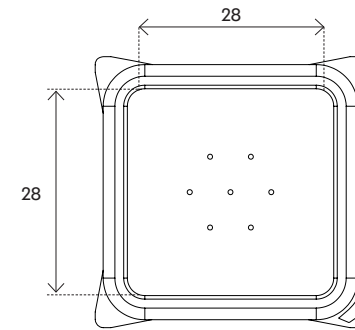
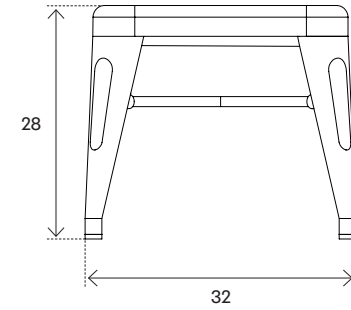
Mouette Kids Stool, *Pure White color*

MOUETTE KIDS STOOL

designer:	Studio Tolix	creation:	2023
guarantee:	two years	fabrication:	handmade in Autun, France
dimensions:	W.32 [CM] D.32 [CM] H.28 [CM]	material:	steel
seat:	W.28 [CM] D.28 [CM] H.28 [CM]	finition:	available page 300
weight:	2.1 [KG]	use:	indoor
highlight:	stackable up to 8 units	assembly:	assembled

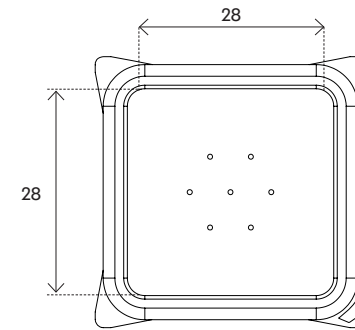
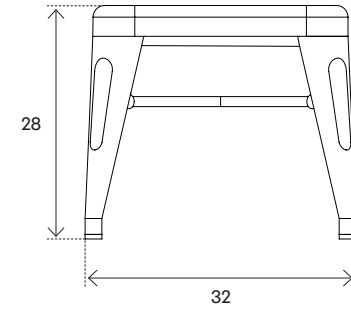
Mouette Kids Stool, *Raw Steel Varnished*

MOUETTE KIDS STOOL VARNISHED

designer:	Studio Tolix	creation:	2023
guarantee:	two years	fabrication:	handmade in Autun, France
dimensions:	W.32 ^[CM] D.32 ^[CM] H.28 ^[CM]	material:	steel
seat:	W.28 ^[CM] D.28 ^[CM] H.28 ^[CM]	finition:	varnished raw steel
weight:	2.1 ^[KG]	use:	indoor
highlight:	stackable up to 8 units	assembly:	assembled

G. COLLECTION

[ed. 2024]

La collection G incarne parfaitement l'ingéniosité et l'héritage transmis par son créateur Xavier Pauchard. Transmission d'un savoir-faire historique maintenu dans notre manufacture : le roulage de l'acier sur un essieu de wagon.

Toute en rondeur, la collection G est conviviale et chaleureuse, mythique et reconnaissable parmi les grands classiques du design. Une pièce emblématique qui traverse les époques avec une grâce indémodable.^[FR]

The G collection perfectly embodies the ingenuity and legacy passed down by its creator, Xavier Pauchard.

The transmission of a historical know-how maintained in our factory: the rolling of steel on a wagon axle.

Rounded and friendly, the G collection is convivial and warm, legendary, and recognizable among the great classics of design. An emblematic piece that transcends the ages with timeless grace.^[EN]

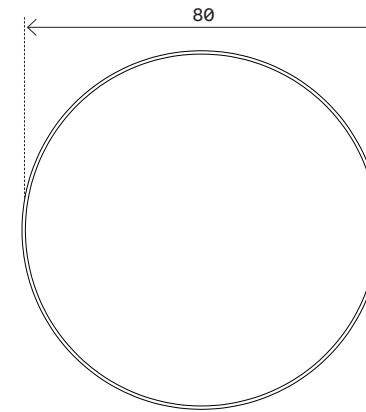
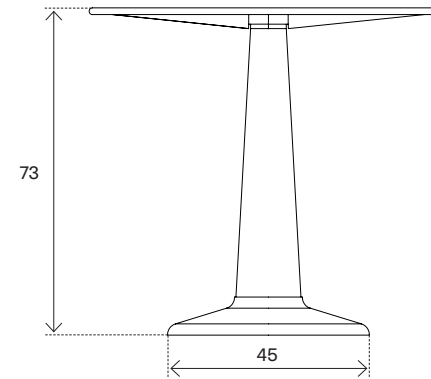

G Table, *Pure White* color

G TABLE

designer:	Xavier Pauchard	creation:	1931
guarantee:	two years	fabrication:	handmade in Autun, France
dimensions:	D.80 ^[CM] H.73 ^[CM] [4 people]	material:	steel
weight:	16,0 ^[KG]	finition:	available page 300
highlight:	non-stackable	use:	indoor
assembly:	to assemble		



G Table, Raw Steel Varnished

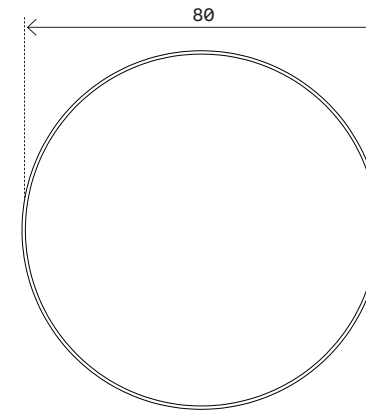
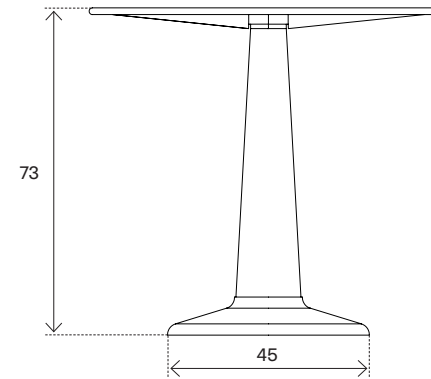

G TABLE VARNISHED

designer:	Xavier Pauchard	creation:	1931
guarantee:	two years	fabrication:	handmade in Autun, France
dimensions:	D.80 ^[CM] H.73 ^[CM] [4 people]	material:	steel
weight:	16,0 ^[KG]	finition:	raw steel varnished
highlight:	non-stackable	use:	indoor
assembly:	to assemble		



77 Pedestal Oblong Table H75, Pure White color

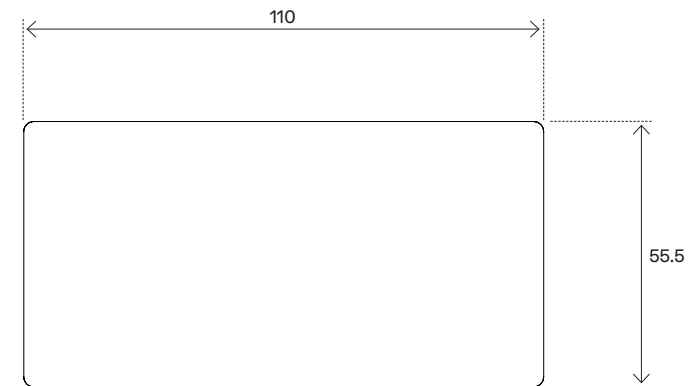
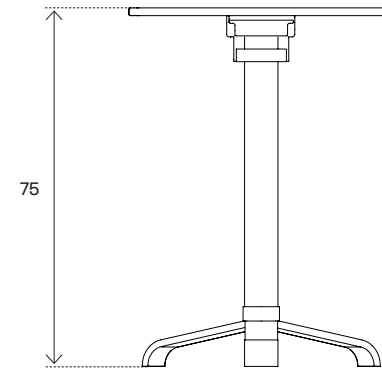

77 PEDESTAL OBLONG TABLE H75

designer:	Studio Tolix	creation:	2024
guarantee:	two years	fabrication:	handmade in Autun, France
dimensions:	W.110 [CM] D.110 [CM] H.75 [CM]	material:	steel
weight:	20.50 [KG]	finition:	available page 300
highlight:	non-stackable	use:	outdoor
assembly:	to assemble		



77 Pedestal Round H75, Pure White color

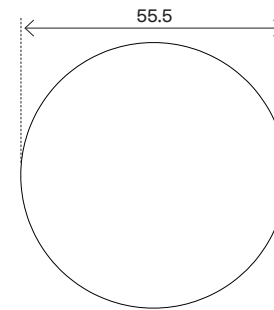
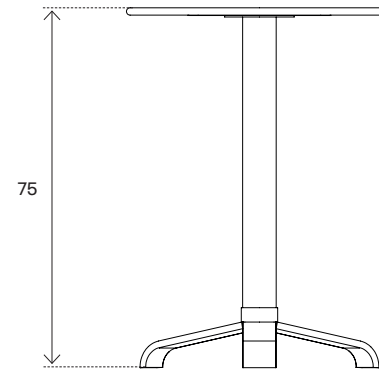

77 PEDESTAL ROUND H75

designer:	Studio Tolix	creation:	2024
guarantee:	two years	fabrication:	handmade in Autun, France
dimensions:	D.55.5 ^[CM] H.75 ^[CM]	material:	steel
weight:	13.30 ^[KG]	finition:	available page 300
highlight:	non-stackable	use:	outdoor
assembly:	to assemble		



77 Pedestal Tilting Round Tray H75, Pure White color

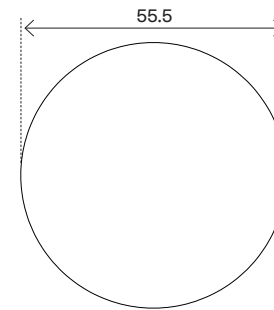
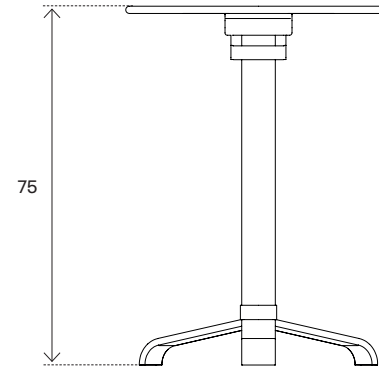

77 PEDESTAL TILTING ROUND TRAY H75

designer:	Studio Tolix	creation:	2024
guarantee:	two years	fabrication:	handmade in Autun, France
dimensions:	D.55.5 ^[CM] H.75 ^[CM]	material:	steel
weight:	17.00 ^[KG]	finition:	available page 300
highlight:	non-stackable	use:	outdoor
assembly:	to assemble		



77 Pedestal Square H75, Pure White color

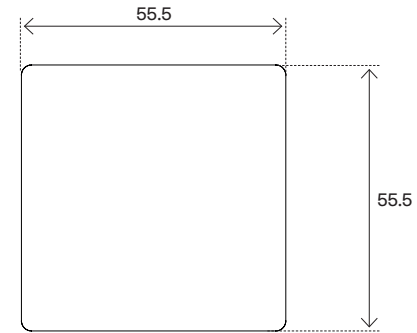
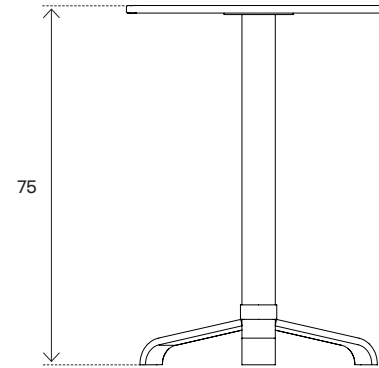

77 PEDESTRAL SQUARE H75

designer:	Studio Tolix	creation:	2024
guarantee:	two years	fabrication:	handmade in Autun, France
dimensions:	W.55.5 ^[CM] D.55.5 ^[CM] H.75 ^[CM]	material:	steel
weight:	13.00 ^[KG]	finition:	available page 300
highlight:	non-stackable	use:	outdoor
assembly:	to assemble		



77 Pedestal Tiling Square Tray H75, Pure White color

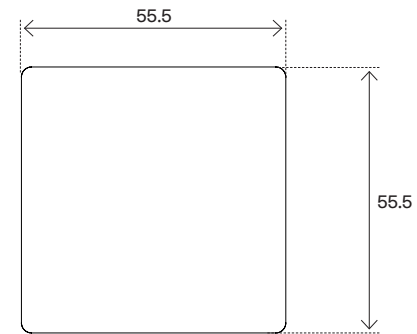
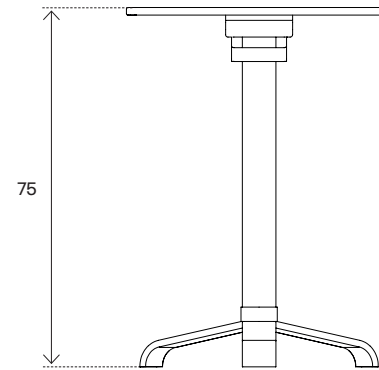

77 PEDESTAL TILTING SQUARE TRAY H75

designer:	Studio Tolix	creation:	2024
guarantee:	two years	fabrication:	handmade in Autun, France
dimensions:	W.55.5 ^[CM] D.55.5 ^[CM] H.75 ^[CM]	material:	steel
weight:	14.50 ^[KG]	finition:	available page 300
highlight:	non-stackable	use:	outdoor
assembly:	to assemble		



77 Pedestal Round H110, Pure White color

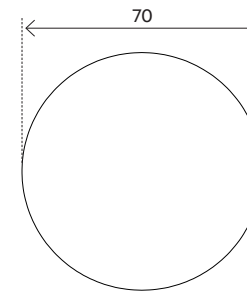
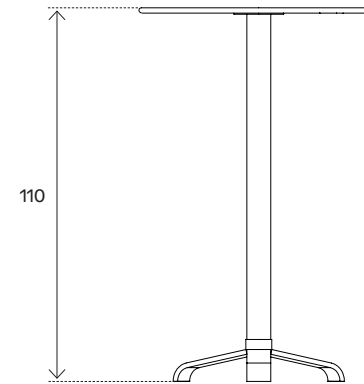

77 PEDESTAL ROUND H110

designer:	Studio Tolix	creation:	2024
guarantee:	two years	fabrication:	handmade in Autun, France
dimensions:	D.70 ^[CM] H.110 ^[CM]	material:	steel
weight:	19.10 ^[KG]	finition:	available page 300
highlight:	non-stackable	use:	outdoor
assembly:	to assemble		



77 Pedestal Square H110, Pure White color

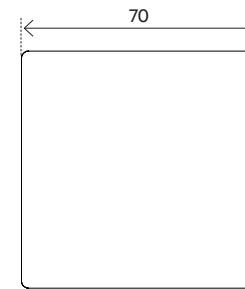
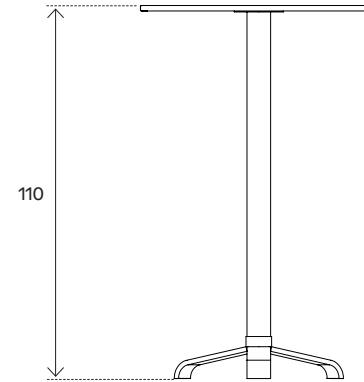

77 PEDESTAL SQUARE H110

designer:	Studio Tolix	creation:	2024
guarantee:	two years	fabrication:	handmade in Autun, France
dimensions:	W.70 [CM] D.70 [CM] H.110 [CM]	material:	steel
weight:	19.10 [KG]	finition:	available page 300
highlight:	non-stackable	use:	outdoor
assembly:	to assemble		



Kub Square Table, *Pure White color*

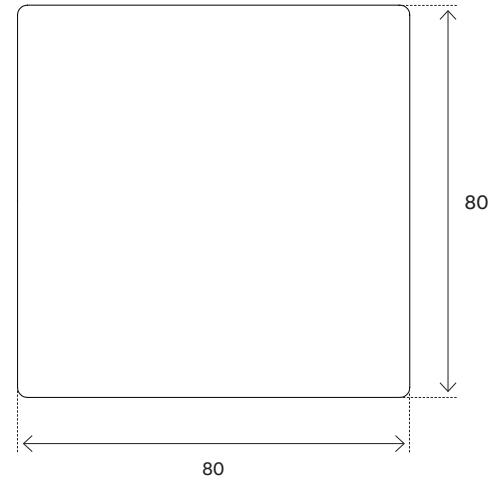
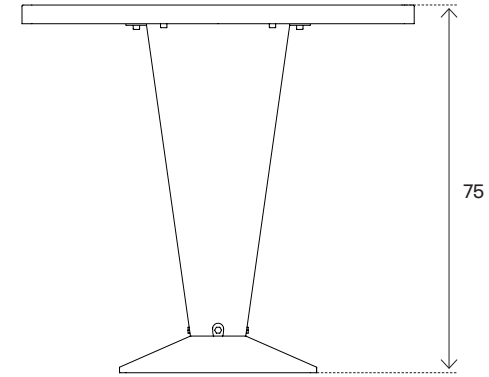
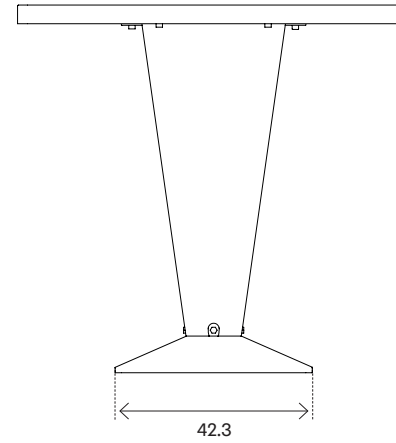

KUB SQUARE TABLE

designer:	Xavier Pauchard	creation:	1938
guarantee:	two years	fabrication:	handmade in Autun, France
dimensions:	W.80 [CM] D.80 [CM] H.75 [CM]	material:	steel
weight:	20.00 [KG]	finition:	available page 300
highlight:	non-stackable	use:	indoor
assembly:	to assemble		



Kub Square Table, Raw Steel Varnished

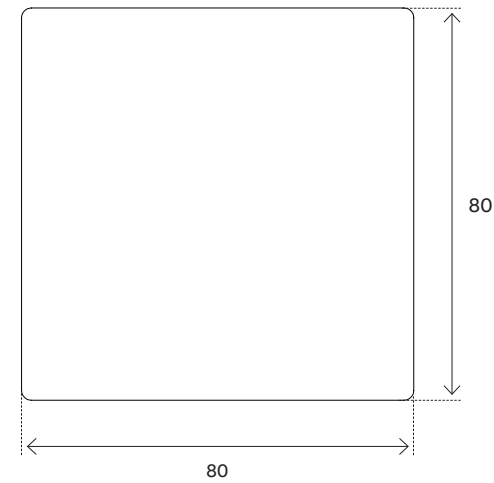
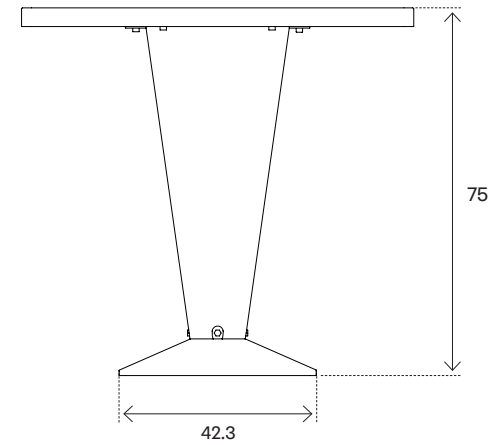

KUB SQUARE TABLE VARNISHED

designer:	Xavier Pauchard	creation:	1938
guarantee:	two years	fabrication:	handmade in Autun, France
dimensions:	W.80 [CM] D.80 [CM] H.75 [CM]	material:	steel
weight:	20.00 [KG]	finition:	varnished raw steel
highlight:	non-stackable	use:	indoor
assembly:	to assemble		

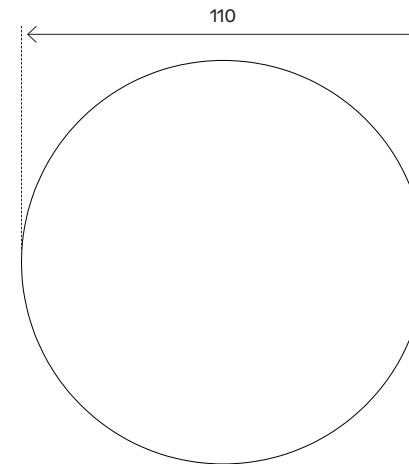
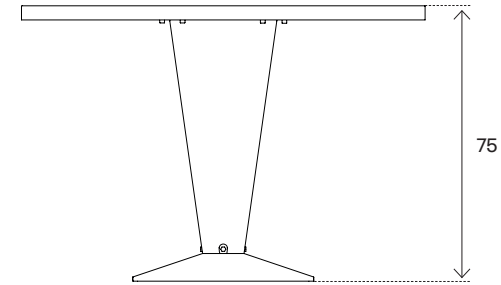
Kub Round Table, *Pure White color*

KUB ROUND TABLE

designer:	Xavier Pauchard	creation:	1938
guarantee:	two years	fabrication:	handmade in Autun, France
dimensions:	D.110 ^[CM] H.75 ^[CM]	material:	steel
weight:	26.80 ^[KG]	finition:	available page 300
highlight:	non-stackable	use:	indoor
assembly:	to assemble		

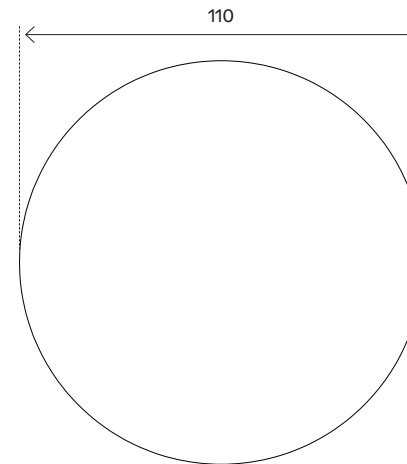
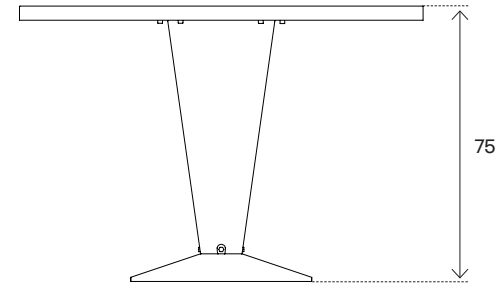
Kub Round Table, *Raw Steel Varnished*

KUB ROUND TABLE VARNISHED

designer:	Xavier Pauchard	creation:	1938
guarantee:	two years	fabrication:	handmade in Autun, France
dimensions:	D.110 ^[CM] H.75 ^[CM]	material:	steel
weight:	26.80 ^[KG]	finition:	varnished raw steel
highlight:	non-stackable	use:	indoor
assembly:	to assemble		

NUANCIER

The color options are available for the entire catalog, while for the galvanized finish, please inquire for details.

Blanc Pur | Pure White [RAL_9010]



Blanc Perlé | Oyster White [RAL_1013]



Gris Beige | Grey Beige [RAL_1019]



Brun Vert | Brown Green [RAL_8000B]



Vert Jonc | Reed Green [RAL_6013]



Vert Mousse | Moss Green [RAL_6005]



Brun Noir | Brown Black [RAL_8022]



Noir Foncé | Jet Black [RAL_9005]



Nuancier

TOLIX STEEL DESIGN S.A.S.
Parc d'activités Saint-Andoche
18, Bd Bernard Giberstein 71400 Autun
sales@tolix.com +33 (0)3 85 86 96 67
www.tolix.com

All our collections are now available
on our web site:
www.tolix.com

For all special orders, contact our sales
department at the following address:
sales@tolix.com
or by telephone at the following number:
+33 (0)3 85 86 96 67

Check our news on our social networks,
instagram, facebook:
@tolixsteeldesign

executives:	Antoine Bejui Emmanuel Diemoz
art direction:	Atelier Franck Durand
photographer:	Éric Heranval
assistant:	Julien Kerdraon

STEEL DESIGN S.A.S.

TOLIX

SIÈGES ET MEUBLES MÉTALLIQUES
DESSIN ET FABRICATION EN FRANCE À AUTUN
MANUFACTURIER—1927

